

# AC Voltage Distributor ES4700.1 V2.0

## Instruction Manual



## **Copyright**

---

The data in this document may not be altered or amended without special notification from ETAS GmbH. ETAS GmbH undertakes no further obligation in relation to this document. The software described in it can only be used if the customer is in possession of a general license agreement or single license. Using and copying is only allowed in concurrence with the specifications stipulated in the contract.

Under no circumstances may any part of this document be copied, reproduced, transmitted, stored in a retrieval system or translated into another language without the express written permission of ETAS GmbH.

© **Copyright 2014** ETAS GmbH, Stuttgart

The names and designations used in this document are trademarks or brands belonging to the respective owners.

ES4700.1 V2.0 R01 EN – 06.2015

---

## Contents

1	Introduction .....	5
1.1	Convention .....	5
1.2	About this Manual .....	5
1.2.1	Content .....	5
1.2.2	User Profile.....	5
1.3	Intended Use .....	5
1.3.1	Intended Use.....	5
1.3.2	Improper Use .....	6
2	Safety Instructions .....	7
2.1	Labeling of Safety Instructions .....	7
2.2	Labeling on the ES4700.1 .....	8
2.3	Safety Advice .....	8
2.4	Safety Instructions for Specific Operating Phases .....	10
2.4.1	Installation and commissioning .....	10
2.4.2	Operation .....	12
2.4.3	Maintenance .....	13
3	ES4700.1 Overview .....	14
4	Technical Data .....	15
4.1	Standards and Norms .....	16
5	Taking the Product Back .....	17
5.1	Taking the Product Back and Recycling.....	17
6	Getting Started .....	18
6.1	Safety Measures.....	18
6.1.1	General Safety Instructions for Operating ES4700.1 .....	18
6.1.2	Opening Component .....	18
6.1.3	The ES4700.1 Power Supply .....	19
7	Operation .....	20
7.1	System Overview .....	20
7.2	Launch .....	21
7.2.1	Disconnection Device .....	21
7.2.2	MAIN SWITCH .....	21
7.2.3	CONTROL ON/OFF switch .....	21
7.2.4	BATTERY ON/OFF switch .....	21
7.2.5	EMERGENCY-STOP switch .....	22
7.3	Automatic circuit breaker .....	22
7.3.1	Automatic circuit breaker F1 .....	22
7.3.2	Automatic circuit breaker F2..F4.....	22
7.3.3	Automatic circuit breaker F5 .....	23
7.3.4	Automatic circuit breaker F6 .....	23
7.4	Status LEDs .....	24

7.4.1	DC Power Supply LEDs .....	24
7.4.2	CONTROL 24V LED .....	24
7.4.3	TEMPERATURE FAIL LED .....	24
7.4.4	EMERGENCY-STOP-EXTERNAL .....	24
8	Interfaces .....	25
8.1	POWER IN Connector .....	25
8.1.1	Pin assignment POWER IN Connector .....	25
8.1.2	Required female connector .....	25
8.2	PROTECTED POWER socket-outlets .....	25
8.2.1	Technical data of PROTECTED POWER socket-outlets .....	26
8.3	DC Power Supplies (DC OUT Connector) .....	26
8.3.1	Pin assignment DC OUT Connector .....	27
8.3.2	Required male connector .....	27
8.3.3	Requirements for insulation of external circuits .....	28
8.4	BATTERY Connector .....	28
8.4.1	Pin assignment BATTERY Connector .....	28
8.4.2	Required female connector .....	28
8.5	ONLY SERVICE plug .....	29
8.5.1	Technical data of ONLY SERVICE power plug .....	29
8.5.2	Pin assignment EMERGENCY STOP connector .....	29
8.5.3	How to connect an external EMERGENCY STOP button .....	30
8.5.4	Not using an external EMERGENCY STOP button .....	30
8.5.5	Required male connector .....	31
8.6	THERMO SWITCH connector .....	32
8.6.1	Pin assignment THERMO SWITCH connector .....	32
8.6.2	Connect a thermo switch circuit .....	32
8.6.3	Not using an thermo switch unit .....	33
8.6.4	Required male connector .....	33
8.7	FAN connector .....	33
8.7.1	Pin assignment FAN connector .....	33
8.7.2	Required male connector .....	34
9	Fuses .....	35
10	Cleaning .....	36
10.1	Cleaning .....	36
11	Troubleshooting .....	37
12	ETAS Contact Addresses .....	38
13	List of abbreviations .....	39

## 1 Introduction

---

This manual contains information on the configuration and launch of ES4700.1 version 2.0. For an overview of ES4700.1 please refer to chapter 3 "ES4700.1 Overview".

### 1.1 Convention

---

The AC Voltage Distributor (ES4700.1 V2.0) is called "ES4700.1" in this document.

### 1.2 About this Manual

---

This section contains a short overview of the contents and provides information on the user profile and on how to use this manual.

#### 1.2.1 Content

---

This manual, "AC Voltage Distributor (ES4700.1) ", consists of the following chapters:

- Chapter 1: "Introduction"  
This chapter contains general information, such as user profile, intended use and conventions used in this document.
- Chapter 2: "Safety Instructions"  
This chapter contains the basic safety instructions for the use of the ES4700.1.
- Chapter 3: "ES4700.1 Overview"  
This chapter contains an overview of the ES4700.1 system.
- Chapter 4: "Technical Data"  
This chapter contains the technical data of the ES4700.1.
- Chapter 5: "Taking the Product Back"  
This chapter describes how to transport the ES4700.1.
- Chapter 6: "Getting Started"  
This chapter describes how to connect the User PC to the ES4700.1.
- Chapter 7: "Operation"  
This chapter describes how to work with ES4700.1.
- Chapter 8: "Interfaces"  
This chapter contains information about each element (switches, connectors, etc.) at the front and back of the ES4700.1
- Chapter 9: "Fuses"  
This chapter describes the ratings of the fuse at the back
- Chapter 10: "Cleaning"  
This chapter contains information about maintenance and cleaning the ES4700.1.
- Chapter 11: "Troubleshooting"  
This chapter contains information about possible error causes.
- Chapter 12: "ETAS Contact Addresses"  
In this chapter you can find information how to contact ETAS.

#### 1.2.2 User Profile

---

This manual is intended for specialists who are familiar with HIL systems.

### 1.3 Intended Use

---

#### 1.3.1 Intended Use

---

The ES4700.1 is designed for the use in industrial laboratories.

It is designed to fulfil the main requirements of the CE conformity for hardware-in-the-Loop systems (HIL). Its task is to protect the user against electrical shock and to avoid fire due to a short circuit or overloading.

It is designed as a built-in unit for ETAS HIL-System (LABCAR), therefore it always has to be mounted in a HIL rack system or comparable system. The rack system or comparable system has to have the at least protection class IP20 or better.

The typical usage of it is the standardized AC voltage distribution of HIL systems components and the optional extension of a HIL system with a emergency circuit unit (emergency stop, over temperature monitoring,...).

If the ES4700.1 is used for any other application as mentioned above, ETAS is not responsible for any injury or damage that may occur.

### 1.3.2 Improper Use

---

The ES4700.1 has to be connected directly to the main power without any additional component in between. It is not allowed to connect the ES4700.1 indirectly to the main power.

The protective earth conductor in the main supply line may not be disconnected or removed.

The ES4700.1 must not be used for the following cases:

- In applications in which the improper use can cause injury or damage
- In environments outside the specified range, refer to chapter 4 "Technical Data"

## 2 Safety Instructions

---

### 2.1 Labeling of Safety Instructions

---

The safety instructions contained in this manual are shown with the standard danger symbol shown below:



The following safety instructions are used. They provide extremely important information. Please read this information carefully.



**CAUTION!**

*Indicates a low-risk danger which could result in minor or less serious injury or damage if not avoided.*



**WARNING!**

*Indicates a possible medium-risk danger which could lead to serious or even fatal injuries if not avoided.*



**DANGER!**

*Indicates a high-risk, immediate danger which could lead to serious or even fatal injuries if not avoided.*

## 2.2 Labeling on the ES4700.1

---



*Risk of an electrical shock*



*General warning => consult documentation*



*protective conductor terminal*

## 2.3 Safety Advice

---



**Warning!** It is critical that you read and follow this safety advice, the product description including technical data and the associated technical documentation, which are facilitated on and to be downloaded from ETAS website, <[www.etas.com](http://www.etas.com)> (via Direct Product Access/select Product). Do not use the product if you cannot read and/or understand the Information for safe operation. If information areas on the ETAS websites are password protected or you do have questions for safe operation, please contact the ETAS hotline in your region <[www.etas.com/hotlines](http://www.etas.com/hotlines)> (password in download area: Man42UaI).

This ETAS product enables users to control systems which accomplish safety functions (e.g. in automobiles, automobile components and test facilities), to change safety relevant data,



or to allocate those for further processing. Hence, the application of this product can be hazardous. Improper use and unskilled application without adequate instruction and experience in handling of such products may cause threats to life and physical conditions as well as damages to property.

Our products have been developed and released exclusively for use in applications defined in this Instruction Manual, chapter 1.3.

Fitness and suitability of the products for any intended use beyond the utilization for which the products have been released (e.g. different stresses/strains or technical conditions) need to be verified by the user on own authority by taking appropriate actions and measures (e.g. by means of tests).

- ETAS products made available as beta versions of firmware, hardware and software are to be used exclusively in testing and evaluation. These products may have not sufficient technical documentation and not fulfil all requirements regarding quality and accuracy for market released series products. Therefore product performance may differ from the product description and your expectations. The product should be used only in controlled test environments. Do not use data and results from beta versions without prior and separate verification and validation and do not pass them to third parties without prior examination.
- Do not use this product if you do not have proper experience and training in using the product.
- To allow proper handling of ETAS products ETAS has released Known Issue Reports (KIR) on its website. Known Issue Reports provide information on known product problems of substantial relevance, including their technical impact, and give instructions on available solutions. Prior to the initial operation of the product you are required to verify whether a KIR is available for the current product version and adhere to available information in the KIR. Known Issue Reports can be found on ETAS website <[www.etas.com/kir](http://www.etas.com/kir)> (Password in KIR area: KETASIR).
- When using this product with systems which accomplish safety functions (e.g. in automobiles, automobile components and test facilities), that influence system behaviour and can affect the safe operation of the system, you must ensure that the system can be transitioned to a safe condition (e.g. emergency shutdown or emergency operation mode) if a malfunction or hazardous incident should occur.
- All applicable regulations and statutes regarding operation must be strictly followed when using this product.

**Warning!** If you fail to follow this safety advice, there might be a risk of death, serious injury or property damage.

The ETAS Group and their representatives shall not be liable for any damage or injury caused by improper use of the product. ETAS provides trainings regarding the proper and intended use of this product.

## 2.4 Safety Instructions for Specific Operating Phases

---

### 2.4.1 Installation and commissioning

---

#### *Installation into ETAS LABCAR system*

---

The ES4700.1 has to be built in an ETAS LABCAR rack with 1RU free space between next components, preferable on top position of the rack system. It has to be set on bar guides (left/right) and has to be screwed with 4 screws (2 left/ 2 right) on the rack system.



**WARNING!**

*The ES4700.1 shall be used always inside in a rack. If not, the electrical shock protection is not guaranteed*



**CAUTION!**

*Never block the top and the bottom – these are absolutely necessary to ensure sufficient ventilation inside the housing.*

*There must be a 1RU free space, between the ES4700.1 and the next component. (top and bottom).*



**CAUTION!**

*The relevant safety device (EMERGENCY-STOP) has to be reached easily and may not be obstructed by any objects*

#### *Earthing of the rack system*

---

The earth bolt of the ES4700.1 (see Fig. 7 1 System overview/17) has to be connected to the earth conductor rail of the rack system.



**WARNING!**

*Risk of electrical shock!*

*If the earth bolt of the ES4700.1 is not connected to the earth conductor rail of the rack, this may result in live housing parts that may cause serious injuries or death.*

*. Touching the housing may result in serious injuries or death.*

*Check the protective earth function regularly.*

#### Connecting a Power Supply to ES4700.1

---

Connect the mounted power supply(ies) of the rack system to the BATTERY connector (see Fig. 7 1 System overview/8).

**WARNING!**

*Risk of electrical shock!*

*Only use certified cables (H07RN-F 5G2,5 mm<sup>2</sup> or corresponding IEC type or equivalent UL type) with specified connector (see chapter 8.4)*

*The cable shall be built by electrically skilled person. Before connecting the cable to the BATTERY connector the connector pin assignment has to be checked against the BATTERY connector pin assignment (see chapter 8.4)*

*Do not connect faulty cables. Remove damaged cables that are already in use from operation immediately.*

The cable has to be fixed at the rack system using cable clamps or zip ties.

### *Connecting devices to the PROTECTED POWER socket-plugs*

---

Connect the mounted devices using a power cord to the PROTECTED POWER socket-plugs ( see Fig. 7 1 System overview/9).

**WARNING!**

*Risk of electrical shock!*

*Only use certified cables (H07RN-F 5G2,5 mm<sup>2</sup> or corresponding IEC type or equivalent UL type) with Schuko plug.*

*The cable shall be built by electrically skilled person.*

*Do not connect faulty cables. Remove damaged cables that are already in use from operation immediately.*

**CAUTION!**

*The maximum current of the POWER PROTECTED socket-outlet may not be exceeded, due to the connected devices*

Pay attention for a balance power drain over the 3 power-sockets.

### *Connection to the Main Power Supply*

---

Connect the main power supply cable from the rack system to the POWER IN connector (see Fig. 7 1 System overview/9).

**WARNING!**

*Risk of electrical shock!*

*Only use certified cables (H07RN-F 5G2,5 mm<sup>2</sup> or corresponding IEC type or equivalent UL type) with specified connector (see chapter 8.2)*

*The cable shall be built by electrically skilled person. Before connecting the cable to the POWER IN connector the connector pin assignment has to be checked against the POWER IN connector pin assignment (see chapter 8.1)*

*Do not connect faulty cables. Remove damaged cables that are already in use from operation immediately.*

The cable has to be fixed at the rack system using cable clamps or zip ties. The cable shall go through the rack system without any tap.

The cable has to be connected to main connection supporting protective earth (PE) and separate neutral line (N)



**WARNING!**

*Risk of electrical shock!*

*If protective earth are not connected, this may result in live housing parts that may cause serious injuries or death.*

*Connect the ES4700.1 only to a main connection with a correctly connected protective earth (PE) an neutral line (N)*

## 2.4.2 Operation

---



**CAUTION!**

*Before using the ES4700.1 the first time in a rack system, the wiring of it has to be approved by an electrically skilled person.*

### *Connection of high power consuming appliance*

---



**WARNING!**

*The maximum current of 16A in the supply line may not be exceeded, due to the connected devices on the BATTERY connector, SERVICE socket-outlet, PROTECTED POWER L1—L3 socket-outlet and X8 DC connector.*

*If not, the protection is not guaranteed*

### *Usage of lead fuses*

---



**CAUTION!**

*Only lead fuses with their defined characteristic (Chapter 9) shall be used. If not, the protection is not guaranteed.*

*Check the lead fuse characteristic of the used fuse, before using it.*

### 2.4.3 Maintenance

---

#### *Protective Earth Connection*

---

**WARNING!**

*Risk of electrical shock!*

*If the protective earth function of the electric supply fails, the housing may become live. Touching the housing may result in serious injuries or death.*

*Check the protective earth function regularly.*

### 3 ES4700.1 Overview

ES4700.1 provides the voltage power supplies to the HIL system through a main switch, circuit breaker. Electronic devices can be connected to protected power plugs used inside the HIL system. The power supply simulating the Battery can be connected to a specific power plug that can be powered separately.

Furthermore, ES4700.1 provides typical DC voltages e.g. 12V, 5V etc. used in a HIL system. These voltages have their respective fuses. An interface for an external emergency stop circuit is also provided. In addition, a thermo switch circuit can be connected to shut off the system in case of overheating. For cooling purposes of the HIL system, a 12V power supply connector is available.



**Fig. 3-1** ES4700.1

## 4 Technical Data

This chapter includes the technical data of the ES4700.1.

<b>Mechanical Data</b>	
Height	3RU
Width	19"
Length	48.5 cm
Weight	10.5 kg
Security class housing	IP20 (IEC 60529)
Safety class	I (IEC 61140)

**Tab. 4-1** Technical data

<b>Electrical power supply</b>	
Voltage	3 phases 208 - 400 VAC
Frequency	50 - 60 Hz
Fuse of power socket	16 A
Internal power consumption	40 Watt (DC output voltages on X8 are not considered)

**Tab. 4-2** Electrical power supply

<b>User accessible DC power supplies (X8 connector)</b>	
Output voltage 24V	24V/ 1.75A
Output voltage 12V	12V/ 3A
Output voltage -12V	-12V/ 3A
Output voltage 5V	5V/ 6,5A

**Tab. 4-3** User accessible DC power supplies

<b>Socket-outlets</b>	
PROTECTED POWER L1 socket-outlet	See chapter 8.2
PROTECTED POWER L2 socket-outlet	See chapter 8.2
PROTECTED POWER L3 socket-outlet	See chapter 8.2
ONLY SERVICE socket-outlet	See chapter 8.5

**Tab. 4-4** Socket-Outlets

<b>Environment Data</b>	
Environment	Usage only in closed and dry rooms.
degree of contamination	2
Operation ambient temperature	5 °C - 40 °C (41 °F - 104 °F)
Storage temperature	-20 °C - +65 °C (-4 °F - 149 °F)
Relative air humidity	0 to 95% (noncondensing)
Altitude	max. 2000 m / 6500 ft

**Tab. 4-5** Environment Data

#### 4.1 Standards and Norms

---

The ES4700.1 complies with following standards and norms.

**Norm**

IEC/EN 61010:2010 and National Deviations for USA (UL61010-1) and Canada (CSA C22.2 No. 61010-1-12) (data for National Deviations is taken from IEC/EN 61010-1-12)

IEC/EN 61000-6-2:2005.

IEC/EN 61000-6-4:2007+A1:2011

**Tab. 4-6** Standards and Norms



## 5 Taking the Product Back

---

### 5.1 Taking the Product Back and Recycling

---

The European Union has passed a directive called Waste Electrical and Electronic Equipment, or WEEE in short, to ensure that systems are setup throughout the EU for the collection, treating and recycling of electronic waste.

This ensures that the devices are recycled in a resource-saving way, representing no danger to health or the environment.

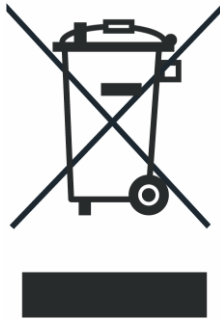

**Fig. 5-1** WEEE symbol

The WEEE symbol on the product or its packaging shows that the product must not be disposed of as residual garbage.

The user is obliged to collect the old devices separately and return them to the WEEE take-back system for recycling.

The WEEE directive concerns all ETAS devices but not the external cables or batteries.

For more information on the ETAS GmbH Recycling Program, contact the ETAS sales and service locations (refer to chapter 12 "ETAS Contact Addresses").

## 6 Getting Started

---

Before you start the set-up procedure, read the following sections carefully, paying particular attention to all notes and warnings:

- Chapter 6.1 "Safety Measures"

This section describes general safety measures which you must adhere to when setting up and operating ES4700.1.

### 6.1 Safety Measures

---

This section describes general safety measures which you must adhere to when setting up and operating ES4700.1.

#### 6.1.1 General Safety Instructions for Operating ES4700.1

---

Before you launch ES4700.1, please read this section carefully.

##### *Ground Connection/Protective Contact*

---

**CAUTION!**

*The ground connection of the overall system is ensured via the protective earth conductor of the power cable. Avoid electric shocks when touching housing parts by ensuring that the mains socket used has correctly connected protective contacts.*

##### *Ventilation*

---

**CAUTION!**

*Never block the top and the bottom – these are absolutely necessary to ensure sufficient ventilation inside the housing.*

*There must be a 1RU free space, between the ES4700.1 and the next component. (top and bottom).*

#### 6.1.2 Opening Component

---

The ES4700.1 must only be opened by qualified, technical personnel!

**CAUTION!**

*As long as ES4700.1 is connected to the power supply, you risk getting an electric shock!*

*Disconnect from the power supply by removing the power cable; then wait a few minutes until all components (e.g. power supply unit, capacitors) are discharged.*

### 6.1.3 The ES4700.1 Power Supply

---

ES4700.1 requires a 3-phase power supply line with earth conductor (PE) and neutral wire (N).

When connecting the ES4700.1, please consider the following points:

- Obey the safety instructions in chapter 2.4.1 "Installation and commissioning".
- Make sure that the relevant safety device (EMERGENCY-STOP) is easy to reach and are not obstructed by objects.
- Make sure that the cable of the main power line has the correct dimension and no defects.  
Carefully check your system specification before connecting your ES4700.1.

For technical data please refer to chapter 4 "Technical Data".

## 7 Operation

### 7.1 System Overview

The following figure shows a front/back view of the ES4700.1 with its components.

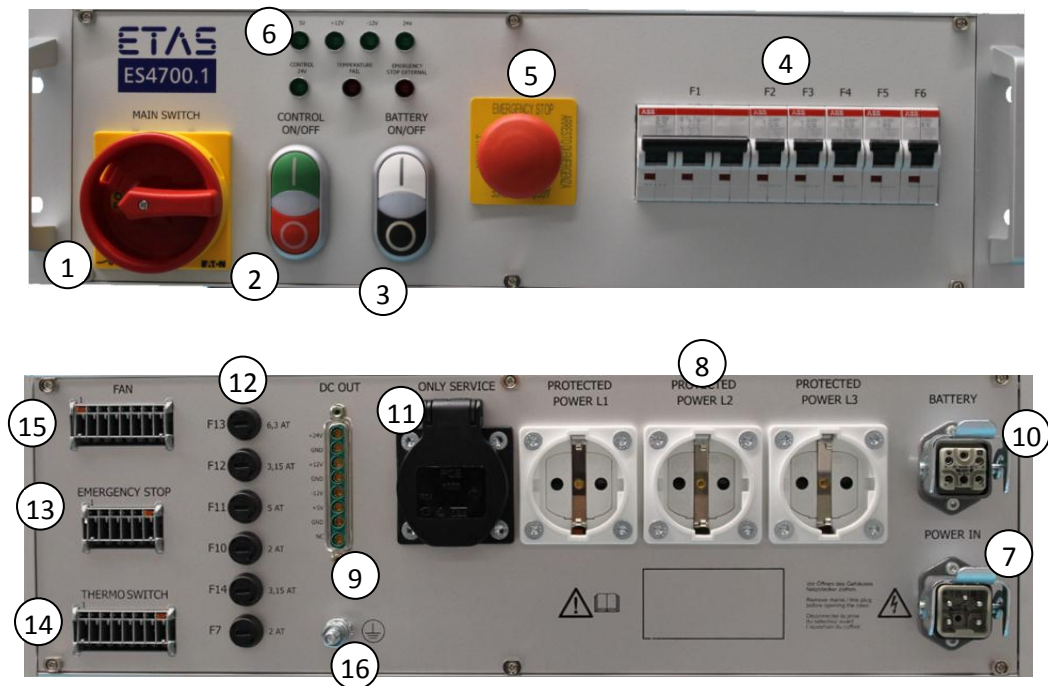

**Fig. 7-1** System overview

The ES4700.1 has the following properties:

Front view:

1. MAIN SWITCH
2. CONTROL ON/OFF switch
3. BATTERY ON/OFF switch
4. Automated circuit breakers
5. EMERGENCY STOP button
6. Status LEDs

Rear view:

7. POWER IN connector
8. PROTECTED POWER socket-outlets
9. DC OUT Connector
10. BATTERY Connector
11. ONLY Service socket-outlet
12. Fuses
13. EMERGENCY STOP connector
14. THERMO SWITCH connector
15. FAN connector
16. Earth bolt

## 7.2 Launch

---

### 7.2.1 Disconnection Device

---

Disconnection device must be provided in the end product.

### 7.2.2 MAIN SWITCH

---

Switching on the MAIN SWITCH provides power to ES4700.1 and to the ONLY SERVICE socket-outlet.



**Fig. 7-2** MAIN switch

### 7.2.3 CONTROL ON/OFF switch

---

Switches on the ES4700.1. All internal components are being powered. Provides power to the PROTECTED POWER L1, -L2 and -L3 power plugs on the back side. The DC voltages on the X8 connector are also available.



**Fig. 7-3** CONTROL ON/OFF switch

### 7.2.4 BATTERY ON/OFF switch

---

Provides power to the BATTERY connector. It can be switched on/off only if the CONTROL ON/OFF switch is activated.



**Fig. 7-4** CONTROL ON/OFF switch

### 7.2.5 EMERGENCY-STOP switch

Pressing the EMERGENCY-STOP button, shuts down the whole system. The button shall be pressed only in case of an emergency.

**Fig. 7-5** CONTROL ON/OFF switch

## 7.3 Automatic circuit breaker

There are several automatic circuit breakers (F1...F6) available to protect the internal devices and also the connected devices in case of a short circuit.

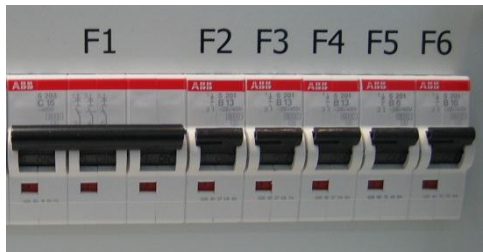
**Fig. 7-6** Automatic circuit breaker

### 7.3.1 Automatic circuit breaker F1

F1 is the main circuit breaker. Fuse rating: 16A

### 7.3.2 Automatic circuit breaker F2..F4

F2 is the circuit breaker for the protected power plug L1. Fuse rating: 13A

F3 is the circuit breaker for the protected power plug L2. Fuse rating: 13A  
F4 is the circuit breaker for the protected power plug L3. Fuse rating: 13A

### 7.3.3 Automatic circuit breaker F5

---

F5 is the circuit breaker for the internal power supply (CONTROL 24V). Fuse rating: 6A

### 7.3.4 Automatic circuit breaker F6

---

F6 is the circuit breaker for the power supplies providing the DC voltages (5V,12V -12V,24V).  
Fuse rating: 16A

## 7.4 Status LEDs

---

There are several status LEDs available to indicate the function state of the internal power supplies and errors states.



**Fig. 7-7** Status LEDs

### 7.4.1 DC Power Supply LEDs

---

The LEDs called 5V, +12V, -12V, 24V indicates whether the respective voltage is available at the DC OUT connector on the back side.

### 7.4.2 CONTROL 24V LED

---

CONTROL 24V indicates whether the internal 24V is available.

### 7.4.3 TEMPERATURE FAIL LED

---

TEMPERATURE FAIL indicates whether the system is shut off by the thermo switch circuit.

### 7.4.4 EMERGENCY-STOP-EXTERNAL

---

EMERGENCY-STOP-EXTERNAL indicates whether the system is shut off externally.



## 8 Interfaces

---

### 8.1 POWER IN Connector

---

Should be connected to the power source using a suitable cable.

#### 8.1.1 Pin assignment POWER IN Connector

---

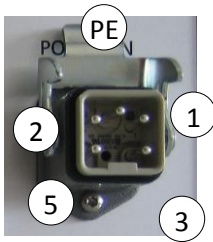

**Fig. 8-1** Connector "POWER IN"

The pin assignment is as follows:

Pin	Signal type	Imax	Signal_Name	Voltage Range
1	Input	16A	L1	0 V...240VAC
2	Input	16A	L2	0 V...240VAC
3	Input	16A	L3	0 V...240 VAC
4	--	--	--	--
5	Input	16A	N	0 VAC
PE	Input	--	PE	--

**Tab. 8-1** Pin assignment of connector "POWER IN"

#### 8.1.2 Required female connector

---

Manufacturer: Harting

- Housing Han 3A-gg-M25 Article Number: 19 20 003 1422
- Han E F Crimp Contact Ag 2.5 mm/14AWG Article Number: 09 33 000 6202
- Han Q 5/0 Female Insert Crimp Article Number: 09 12 005 3101

### 8.2 PROTECTED POWER socket-outlets

---

Three protected power socket-outlets are available:

- PROTECTED POWER L1
- PROTECTED POWER L2

- PROTECTED POWER L3

Each power plug is protected through an automated circuit breaker.

These power plug connectors are used typically for the internal devices of a HIL system. Pay attention for a balanced power drain.

### 8.2.1 Technical data of PROTECTED POWER socket-outlets



**Fig. 8-2** Connector „PROTECTED POWER L1 .. L3"

Technical data:

Power plug	I <sub>max</sub>	Voltage Range
PROTECTED POWER L1	13A <sup>1)</sup>	0 V...240VAC
PROTECTED POWER L2	13A <sup>1)</sup>	0 V...240VAC
PROTECTED POWER L3	13A <sup>1)</sup>	0 V...240VAC

**Tab. 8-2** Technical data „PROTECTED POWER L1 .. L3"

Each socket-outlet is protected by a 13A automated circuit breaker.

**<sup>1)</sup>Note:**

The maximum current depends on the overall current consumption on the phase (L<sub>x</sub>) of POWER IN connector. The maximum current per phase is 16A. This limit may not be exceeded. The maximum current per PROTECTED POWER power plug can be calculated as follows:

$$I_{\text{PROTECTED POWER L1}} \leq 16A - I_{\text{Battery\_L1}} - I_{\text{ONLY\_SERVICE}} - 1A$$

$$I_{\text{PROTECTED POWER L2}} \leq 16A - I_{\text{Battery\_L2}}$$

$$I_{\text{PROTECTED POWER L3}} \leq 16A - I_{\text{Battery\_L3}}$$

but always less than 13A

### 8.3 DC Power Supplies (DC OUT Connector)

The ES4700.1 is equipped with different DC power supplies. Following DC voltages are available:

+5V, +12V, -12V, +24V

The DC voltages are independent from each other. Each of the DC voltage has their own ground potential. The ground potentials can be connected together to get a common ground potential.

Each individual voltage is protected through a lead fuse. The fuses are:

- F10 for +24V DC      Fuse rating: see table "Tab. 9 1 Fuses"
- F11 for +12V DC      Fuse rating: see table "Tab. 9 1 Fuses"
- F12 for -12V DC      Fuse rating: see table "Tab. 9 1 Fuses"
- F13 for +5V DC      Fuse rating: see table "Tab. 9 1 Fuses"

The fuses are located on the back side of ES4700.1.

8.3.1 Pin assignment DC OUT Connector

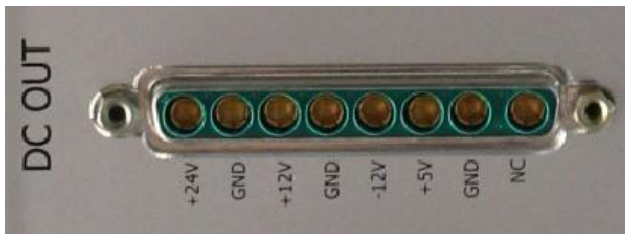

**Fig. 8-3** Connector "DC-OUT-Connector"

The pin assignment is as follows:

Pin	Signal type	I <sub>max</sub>	Signal_Name	Voltage Range
1	n.c	--	--	--
2	GND	--	5V GND	GND
3	Output	6.5 A	+5V	5V +/- 10%
4	Output	3 A	-12V	-12V +/- 10%
5	GND	--	12V GND	GND
6	Output	3 A	+12V	+12V +/- 10%
7	GND	--	24V GND	GND
8	Output	1.75 A	+24V	24V +/- 10%

**Tab. 8-3** Pin assignment of connector "DC-OUT"

8.3.2 Required male connector

Manufacturer: Harting

- DSUB MA 8W8 SHELL W/O CONTACTS      Article Number: 09 69 410 0088

- D SUB MIXED MA 10A PL3 sold.pow.contact Article Number: 09 69 281 7420

8.3.3 Requirements for insulation of external circuits

Double or reinforced isolation required to hazard life circuits.

8.4 BATTERY Connector

Connects the power supply simulating the Battery using a suitable cable (16A 220V/400V 3-Phases). The BATTERY connector is protected through the main automatic circuit breaker F1 (16A).

8.4.1 Pin assignment BATTERY Connector

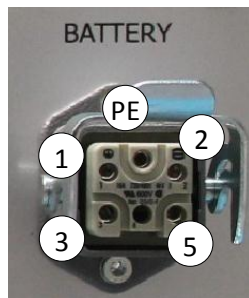

**Fig. 8-4** Connector "BATTERY"

The pin assignment is as follows:

Pin	Signal type	I <sub>max</sub>	Signal_Name	Voltage Range
1	Output	9A	L1	0 V...240VAC
2	Output	9A	L2	0 V...240VAC
3	Output	9A	L3	0 V...240 VAC
4	--	--	--	--
5	--	--	N	--
PE	--	--	PE	--

**Tab. 8-4** Pin assignment of connector "BATTERY"

8.4.2 Required female connector

Manufacturer: Harting

- Housing Han 3A-gg-M25 Article Number: 19 20 003 1422
- Han E M Crimp Contact Ag 2.5 mm / 14AWG Article Number: 09 33 000 6102
- Han Q 5/0 Male Insert Crimp Article Number: 09 12 005 3001

8.5 ONLY SERVICE plug

This socket-outlet shall be used ONLY for the system’s service. The power plug is directly powered if the MAIN SWITCH is on. The power plug is protected through the main circuit breaker F1 (16A).

8.5.1 Technical data of ONLY SERVICE power plug



**Fig. 8-5** Connector „ONLY SERVICE“

Technical data:

Power plug	I <sub>max</sub>	Voltage Range
ONLY SERVICE	16A <sup>1)</sup>	0 V...240VAC

**Tab. 8-5** Technical data „ONLY SERVICE power plug“

<sup>1)</sup>**Note:**

The maximum current depends on the overall current consumption on the phase (Lx) of POWER IN connector. The overall maximum current per phase is 16A. This limit may not be exceeded. The maximum current of the ONLY SERVICE power plug can be calculated as described below:

$$I_{\text{ONLY\_SERVICE}} \leq 16A - I_{\text{Battery\_L1}} - I_{\text{PROTECTED POWER L1}}$$

EMERGENCY STOP connector

Interface for an external emergency stop circuit. The interface is designed with two safety channels. The interface allows interrupting the two safety signals of the used safety relay (PNOZ S4 24V DC). If no external emergency stop button is used, the two safety channels have to be closed otherwise the system can’t be switched on.

8.5.2 Pin assignment EMERGENCY STOP connector



**Fig. 8-6** Connector "EMERGENCY STOP"

The pin assignment is as follows:

Pin	Signal type	I <sub>max</sub> (A)	Signal_Name	Voltage Range
1 (see marking)	Signal		S22	*
2	Signal		S21	*
3	Signal		S11	*
4	Signal	--	S12	*
5	Output	1.6A	+24V CONTROL	24V +/- 10%
6	INPUT	10mA	LED EMERGENCY EXTERNAL	0..24V

**Tab. 8-6** Pin assignment of connector "EMERGENCY STOP"

\* Control signals from the safety relay PNOZ S4 24 DC

### 8.5.3 How to connect an external EMERGENCY STOP button

Example how to connect an external emergency button

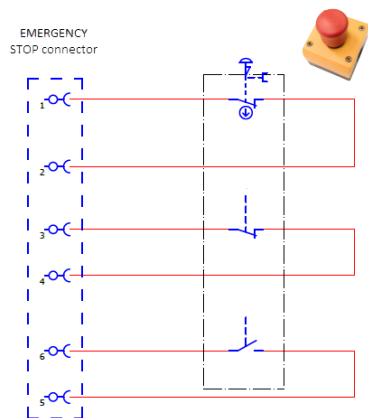

**Fig. 8-7** Connect external EMERGENCY STOP button

### 8.5.4 Not using an external EMERGENCY STOP button

Connect the pins of the EMERGENCY STOP connector as follow:

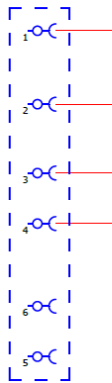
EMERGENCY  
STOP connector**Fig. 8-8** Not using an external EMERGENCY STOP button

### 8.5.5 Required male connector

---

Manufacturer: WAGO

- 1-Conductor female plug; straight; Article Number: 769-106
- Snap-on type strain relief housing Article Number: 769-1606
- Cable clamp; for strain relief Article Number: 209-174
- Fixing screw; for cable clamp Article Number: 209-173

8.6 THERMO SWITCH connector

Interface to connect an external thermo switch circuit. If no thermo switch is used, the thermo switch circuit has to be closed otherwise the system can't be switched on.

8.6.1 Pin assignment THERMO SWITCH connector

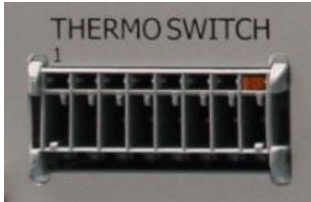

**Fig. 8-9** Connector "THERMO SWITCH"

The pin assignment is as follows:

Pin	Signal type	Imax	Signal_Name	Voltage Range
1	Output	1.6A	Fan_Control_1	24V +/- 10%
2	Signal	1.6A	Fan_Control_2	24V +/- 10%
3	Signal	1.6A	Thermo_1	24V +/- 10%
4	Signal	1.6A	Thermo_1	24V +/- 10%
5	nc.	--	--	--
6	nc.	--	--	--
7	nc.	--	--	--
8	nc.	--	--	--

**Tab. 8-7** Pin assignment of connector "THERMO SWITCH"

8.6.2 Connect a thermo switch circuit

Example how to connect an external emergency button

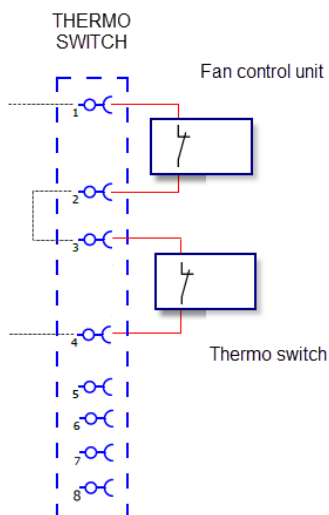
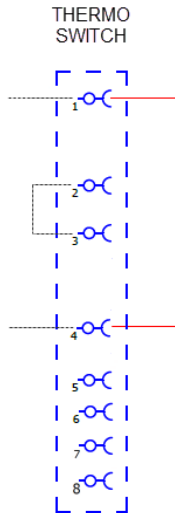



**Fig. 8-10** Connect a thermo switch circuit

8.6.3 Not using an thermo switch unit

Connect the pins of the THERMO SWITCH connector as follow:



**Fig. 8-11** Not using an thermo switch circuit

8.6.4 Required male connector

Manufacturer: WAGO

- 1-Conductor female plug; straight; Article Number: 769-108
- Snap-on type strain relief housing Article Number: 769-1608
- Cable clamp; for strain relief Article Number: 209-174
- Fixing screw; for cable clamp Article Number: 209-173

8.7 FAN connector

Use for connecting the ventilation unit of the HIL system. A 12V/2A DC voltage is provided protected through fuse F14.

8.7.1 Pin assignment FAN connector



**Fig. 8-12** Connector "FAN"

The pin assignment is as follows:

Pin	Signal type	I <sub>max</sub>	Signal_Name	Voltage Range
1	Output	2A/4	DC_FAN_12V	12V +/- 10%
2	Output	2A/4	DC_FAN_12V	12V +/- 10%
3	Output	2A/4	DC_FAN_12V	12V +/- 10%
4	Output	2A/4	DC_FAN_12V	12V +/- 10%
5	GND	--	DC_FAN_GND	--
6	GND	--	DC_FAN_GND	--
7	GND	--	DC_FAN_GND	--
8	GND	--	DC_FAN_GND	--

**Tab. 8-8** Pin assignment of connector "FAN"

### 8.7.2 Required male connector

---

Manufacturer: WAGO

- 1-Conductor female plug; straight; Article Number: 769-108
- Snap-on type strain relief housing Article Number: 769-1608
- Cable clamp; for strain relief Article Number: 209-174
- Fixing screw; for cable clamp Article Number: 209-173

**9 Fuses**

---

<b>Fuse</b>	<b>Comment</b>	<b>Fuse rating</b>
F7	for +24V DC internal CONTROL power supply	1.6AT/250V/H (5 x 20)
F10	for +24V DC power supply	1.6AT /250V/H (5 x 20)
F11	for +12V DC power supply	2.5AT /250V/H (5 x 20)
F12	for -12V DC power supply	2.5AT /250V/H (5 x 20)
F13	for +5V DC power supply	6.3AT /250V/H (5 x 20)
F14	for +12V DC FAN power supply	2.5AT /250V/H (5 x 20)

**Tab. 9-1** Fuses

## 10 Cleaning

---

In this chapter you find information regarding cleaning of the ES4700.1.

### 10.1 Cleaning

---

**WARNING!**

*Risk of electrical shock!*

*Before cleaning the housing, remove the power cable.*

**CAUTION!**

*Risk of damage!*

*HiL ES4700.1 and its components are not waterproof. Avoid contact with water and any other liquids.*

- Clean the housing only with a dry cloth. You must not use detergents or solvents.

## 11 Troubleshooting

**Tab. 11-1** shows possible faults for the ES4700.1. When it is not possible to eliminate the error cause, please contact ETAS (for ETAS contact information, refer to chapter 122 "ETAS Contact Addresses").

<b>Fault</b>	<b>Error cause</b>	<b>Solution</b>
Battery supply does not work	Button "EMERGENCY STOP" is pressed	Release the button "EMERGENCY STOP"
	THERMO connector is not closed	Close the THERMO connector
System is not running	Emergency button is pressed	Release the button "EMERGENCY STOP"
	Main circuit fuse released	Enable fuse
	Blown fuse "F7"	Replace fuse (on rear side)
DC +24V not available	Blown fuse "F10"	Replace fuse (on rear side)
DC +12V not available	Blown fuse "F11"	Replace fuse (on rear side)
DC -12V not available	Blown fuse "F12"	Replace fuse (on rear side)
DC +5V not available	Blown fuse "F13"	Replace fuse (on rear side)
FAN DC +12V not available	Blown fuse "F14"	Replace fuse (on rear side)

**Tab. 11-1** Fault, error cause, solution

## 12 **ETAS Contact Addresses**

---

### *ETAS HQ*

---

ETAS GmbH

Borsigstraße 14

70469 Stuttgart

Germany

Phone: +49 711 3423-0

Fax: +49 711 3423-106

WWW: [www.etas.com](http://www.etas.com)

### *ETAS Subsidiaries and Technical Support*

---

For details of your local sales office as well as your local technical support team and product hotlines, take a look at the ETAS website:

ETAS subsidiaries                      WWW: [www.etas.com/en/contact.php](http://www.etas.com/en/contact.php)

ETAS technical support                WWW: [www.etas.com/en/hotlines.php](http://www.etas.com/en/hotlines.php)

**13 List of abbreviations**

---

HIL	Hardware-in-the-Loop
I/O	Input/Output
RU	Rack unit

**Tab. 13-1** List of abbreviations

---

## Figures

<b>Fig. 3-1</b>	ES4700.1 .....	14
<b>Fig. 5-1</b>	WEEE symbol .....	17
<b>Fig. 7-1</b>	System overview .....	20
<b>Fig. 7-2</b>	MAIN switch .....	21
<b>Fig. 7-3</b>	CONTROL ON/OFF switch .....	21
<b>Fig. 7-4</b>	CONTROL ON/OFF switch .....	22
<b>Fig. 7-5</b>	CONTROL ON/OFF switch .....	22
<b>Fig. 7-6</b>	Automatic circuit breaker .....	22
<b>Fig. 7-8</b>	Status LEDs .....	24
<b>Fig. 8-1</b>	Connector "POWER IN" .....	25
<b>Fig. 8-2</b>	Connector „PROTECTED POWER L1 .. L3" .....	26
<b>Fig. 8-3</b>	Connector "DC-OUT-Connector" .....	27
<b>Fig. 8-4</b>	Connector "BATTERY" .....	28
<b>Fig. 8-5</b>	Connector „ONLY SERVICE" .....	29
<b>Fig. 8-6</b>	Connector "EMERGENCY STOP" .....	29
<b>Fig. 8-7</b>	Connect external EMERGENCY STOP button .....	30
<b>Fig. 8-8</b>	Not using an external EMERGENCY STOP button .....	31
<b>Fig. 8-9</b>	Connector "THERMO SWITCH" .....	32
<b>Fig. 8-10</b>	Connect a thermo switch circuit .....	33
<b>Fig. 8-11</b>	Not using an thermo switch circuit .....	33
<b>Fig. 8-12</b>	Connector "FAN" .....	33



---

## Tables

<b>Tab. 4-1</b>	Technical data.....	15
<b>Tab. 4-2</b>	Electrical power supply .....	15
<b>Tab. 4-3</b>	User accessible DC power supplies .....	15
<b>Tab. 4-4</b>	Socket-Outlets .....	15
<b>Tab. 4-5</b>	Environment Data .....	15
<b>Tab. 4-6</b>	Standards and Norms .....	16
<b>Tab. 8-1</b>	Pin assignment of connector "POWER IN" .....	25
<b>Tab. 8-2</b>	Technical data „PROTECTED POWER L1 .. L3" .....	26
<b>Tab. 8-3</b>	Pin assignment of connector "DC-OUT" .....	27
<b>Tab. 8-4</b>	Pin assignment of connector "BATTERY" .....	28
<b>Tab. 8-5</b>	Technical data „ONLY SERVICE power plug" .....	29
<b>Tab. 8-6</b>	Pin assignment of connector "EMERGENCY STOP" .....	30
<b>Tab. 8-7</b>	Pin assignment of connector "THERMO SWITCH" .....	32
<b>Tab. 8-8</b>	Pin assignment of connector "FAN" .....	34
<b>Tab. 9-1</b>	Fuses .....	35
<b>Tab. 11-1</b>	Fault, error cause, solution.....	37
<b>Tab. 13-1</b>	List of abbreviations .....	39

---

## Index

### A

Automatic circuit breaker 22

### B

Basic safety instructions 7  
BATTERY connector 28  
BATTERY ON/OFF switch 21

### C

Cleaning 36  
CONTROL ON/OFF switch 21

### D

DC OUT Connector 26

### E

EMERGENCY STOP connector 29  
EMERGENCY-STOP switch 22  
ES4700.1 14  
ETAS contact addresses 38  
ETAS subsidiaries 38

### F

F1 22  
F2..F4 22  
F5 23  
F6 23  
FAN connector 33  
Fuses 35

### G

Getting started 18  
Ground connection 18

### I

Improper use 6  
Index 42  
Intended use 5

### L

LED 24  
List of abbreviations 39

### M

MAIN SWITCH 21

### O

ONLY SERVICE power plug 29  
Operation 20

### P

POWER IN 25  
PROTECTED POWER Lx power plug 25  
Protective contact 18

### T

Taking the product back and recycling 17  
Technical data 6, 15  
Technical support 38  
THERMO SWITCH connector 32  
Troubleshooting 37

### U

User profile 5

### V

Ventilation 18

