ETKP7.0

**Emulator Probe for MPC561/562 and
MPC563/564**

Data Sheet

Copyright

The data in this document may not be altered or amended without special notification from ETAS GmbH. ETAS GmbH undertakes no further obligation in relation to this document. The software described in it can only be used if the customer is in possession of a general license agreement or single license. Using and copying is only allowed in concurrence with the specifications stipulated in the contract.

Under no circumstances may any part of this document be copied, reproduced, transmitted, stored in a retrieval system or translated into another language without the express written permission of ETAS GmbH.

© **Copyright 2007** ETAS GmbH, Stuttgart

The names and designations used in this document are trademarks or brands belonging to the respective owners.

Document QH110515 R2.0.0 EN

TTN

Contents

1	General Information	7
1.1	Basic Safety Instructions	7
1.1.1	Product liability.	7
1.1.2	Correct Use	7
1.1.3	Labeling of Safety Instructions	8
1.2	Taking the Product Back and Recycling	8
1.3	About This Manual	9
1.3.1	Described ETKP7.0 Hardware State.	9
1.3.2	Structure	9
1.3.3	Using this Manual.	10
2	Introduction	11
2.1	Applications	11
2.2	Features	11
2.3	Supported Microcontrollers	12
3	Hardware Description	13
3.1	Architecture	13
3.2	Microcontroller Interface	14
3.3	BGA Connector	15
3.4	Data Emulation and Measurement Data Memory	15

3.4.1	Data Emulation Memory	15
3.4.2	Measurement Data Memory	16
3.4.3	Triggering of Measurement Data Capture	16
3.4.4	Data Retention in Data Emulation Memory	18
3.4.5	ETKP7.0 Deactivation	18
3.5	Data Flash Memory	18
3.6	Code Flash Memory	19
3.7	Power Supply	20
3.8	Serial ETK Interface	21
3.9	Status LEDs	22
3.10	Chip Select Configuration Bridge	23
4	Installation	25
4.1	Connection to the ECU	25
4.2	Connecting to the Power Supply	26
4.2.1	Permanent Power Supply inside ECU available	26
4.2.2	Permanent Power Supply inside ECU not available	26
4.2.3	Isolated Power Supply inside ECU	27
5	ETK Configuration	29
5.1	Overview	29
5.2	ETK Configuration Tool	29
5.3	Configuration Parameter	30
6	Technical Data	31
6.1	General Information	31
6.1.1	Described ETKP7.0 Hardware State	31
6.1.2	Measurement Conditions	31
6.2	System Requirements	31
6.2.1	Software Support	31
6.2.2	Hardware	32
6.3	Supported Microcontroller	32
6.4	Configuration	32
6.5	Serial ETK Interface	33
6.6	Power Supply	33
6.7	Testcharacteristics	34
6.8	Electrical Characteristics	35
6.9	Switching Characteristics	36
6.9.1	Read Timing: Data Emulation and Measurement Data DPR	37
6.9.2	Write Timing: Data Emulation and Measurement Data DPR	37
6.10	Environmental Conditions	38

6.11	Pin Assignment	38
6.12	Mechanical Dimensions	38
6.12.1	General Dimensions	38
6.12.2	Microcontroller with BGA Adapter and Socket mounted	40
6.12.3	Microcontroller soldered on ETK	40
7	Cables	41
7.1	Interface Cables	41
7.1.1	Interface Cable KA54 with PG Cable Gland	41
7.1.2	Interface Cable KA55	43
7.2	Power Supply Cables	44
7.2.1	Cable ETV	44
7.2.2	Cable K70	44
7.2.3	Cable KA50	45
7.2.4	Cable CBM200	45
8	Ordering Information	47
8.1	ETKP7.0	47
8.2	Sockets	47
8.3	Adapters	48
8.4	Isolated Power Supply	48
8.5	Cables	48
8.5.1	Interface Cables	48
8.5.2	Power Supply Cables	49
9	Version History	51
10	ETAS Contact Addresses	53
	List of Figures	55
	Index	57

1 **General Information**

The introductory chapter provides you with information on the basic safety instructions, returning the product and recycling, and how to use this manual.

1.1 **Basic Safety Instructions**

Please adhere to the following safety instructions to avoid injury to yourself and others as well as damage to the device.

1.1.1 **Product liability**

This manual addresses qualified personnel working in the fields of automobile control unit development and calibration. Specialized knowledge in the areas of measurement and control unit technology is required.



WARNING!

*Integrating this module in your system changes the application system's response!
If an error or unexpected operation results occur, the response of your application system can be critical!
Only use the module in application systems equipped with additional safety or redundant systems (e.g. an emergency or backup system)!*

Liability cannot be accepted for damage caused by non adherence to the instructions contained in this document!



CAUTION!

*Some components of the interface board may be damaged or destroyed by electrostatic discharges. Please keep the board in its storage package until it is installed.
The board should only be taken from its package, configured, and installed at a work place that is protected against static discharge.*

1.1.2 **Correct Use**

ETAS GmbH cannot be made liable for damage which is caused by incorrect use and not adhering to the safety instructions.

1.1.3 Labeling of Safety Instructions

The safety instructions contained in this manual are shown with the standard safety symbol shown in Fig. 1-1.



Fig. 1-1 Standard Safety Symbol

The following safety instructions are used. They provide extremely important information. Please read this information carefully.



WARNING!

Indicates a possible medium-risk danger which could lead to serious or even fatal injuries if not avoided.



CAUTION!

Indicates a low-risk danger which could result in minor or less serious injury or damage if not avoided.

1.2 Taking the Product Back and Recycling

The European Union has passed a directive called Waste Electrical and Electronic Equipment, or WEEE for short, to ensure that systems are setup throughout the EU for the collection, treating and recycling of electronic waste.

This ensures that the devices are recycled in a resource-saving way representing no danger to health or the environment.



Fig. 1-2 WEEE Symbol

The WEEE symbol (see Fig. 1-2 on page 8) on the product or its packaging shows that the product must not be disposed of as residual garbage.

The user is obliged to collect the old devices separately and return them to the WEEE take-back system for recycling.

The WEEE directive concerns all ETAS devices but not external cables or batteries.

For more information on the ETAS GmbH Recycling Program, contact the ETAS sales and service locations (see chapter 10 on page 53).

1.3 About This Manual

This manual describes the startup and technical data of the ETKP7.0 Emulator Test Probe.

1.3.1 Described ETKP7.0 Hardware State

A sticker on the top of the ETKP7.0 allows you to indicate the ETKP7.0 PCB revision, if you use the hardware state syntax.

Hardware state syntax	Meaning
aabccc/dd	"b" indicates the PCB revision

Note

This manual describes the ETKP7.0, PCB revision "E" and up.

1.3.2 Structure

This manual consists of nine chapters and an index.

- **Chapter 1: "General Information"**
The "General Information" (this chapter) provides you with information on the basic safety instructions, returning the product and recycling, and how to use this manual.
- **Chapter 2: "Introduction"**
The chapter "Introduction" contains information about the basic features and applications of the ETKP7.0 Interface Board (ETK = Emulator Test Probe), hints to system requirements for operating the ETKP7.0, and other details.
- **Chapter 3: "Hardware Description"**
In the "Hardware Description" chapter the function blocks and the interfaces of the ETKP7.0 are explained in detail.
- **Chapter 4: "Installation"**
The "Installation" chapter describes the hardware installation of the ETKP7.0.

- **Chapter 5: “ETK Configuration”**

The “ETK Configuration” chapter includes a description of important ETKP7.0 configuration parameters.

- **Chapter 6: “Technical Data”**

The “Technical Data” chapter contains a summary of all technical data and pin assignments of the ETKP7.0.

- **Chapter 7: “Cables and Accessories”**

The “Cables and Accessories” chapter contains an overview of the available cables and accessories.

- **Chapter 8: “Ordering Information”**

The “Ordering Information” chapter contains the ordering information on the available cables and accessories.

- **Chapter 9: “Version History”**

The “Version History” chapter contains a summary of the changes in this document version.

The final chapter, “ETAS Contacts”, gives you information on ETAS’ international sales and service locations.

1.3.3 Using this Manual

Typographic Conventions

The following typographic conventions are used:

Bold Device labels

Italics Crucial text

Important notes for the user are shown as follows:

Note _____

Important note for the user.

2 Introduction

This section contains general safety instructions, information about the basic features and applications of the ETKP7.0 Interface Board (ETK = Emulator Test Probe), hints to system requirements, and delivery scope.

2.1 Applications

The ETKP7.0 is an emulator probe especially for the Freescale MPC561/562 and MPC563/564 microcontrollers.

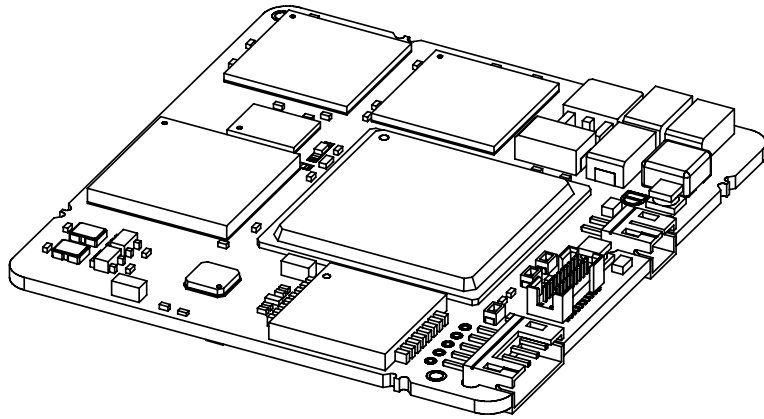

Fig. 2-1 ETKP7.0

It is compatible with the ETAS calibration and development system interface (e.g. ES690, ES590, ES591 and ES1000.2/ES1000.3 with ES1232-A).

2.2 Features

- Applicable for an external Freescale 16-bit microcontroller bus
- Supports 16- and 8-bit access to the data emulation memory
- Usable in 3.3 V systems (no 5 V tolerant data bus)
- Two pages of data emulation/measurement data memory available, each with 512 kByte
- Permanent storage of emulation data in FLASH memory
- Serial interface with 8/100 Mbit/s to the calibration and development system
- Permanent storage of configuration in E²PROM

- Firmware update (programming of the logic device) through software; removal of ETK or ECU not necessary.
- Power supply: 4.3 V to 18 V DC
- Temperature range: -40 °C to +110 °C
- Dimensions: ca. 61 mm x 64 mm x 10 mm

For more technical data on the ETKP7.0 and for system requirements refer the chapter "Technical Data" on page 31.

2.3 Supported Microcontrollers

Type	Supported microcontrollers
ETKP7.0	Freescale MPC561/562, MPC563/564

3 Hardware Description

This section contains information about the basic features and applications of the ETKP7.0 Interface Board (ETK = Emulator Test Probe), hints to system requirements for operating the ETKP7.0, and other details.

3.1 Architecture

Fig. 3-1 "ETKP7.0 Architecture" shows the blockdiagram of the ETKP7.0. The connection to the ECU is made by an BGA connector.

The microcontroller can read directly from one of the two pages of the data emulation memory and can write its data directly to the measurement data memory. These two memories (data emulation memory, measurement data memory) are using the same address space and are realized inside the same DPRs. Through the BGA connector the microcontroller can communicate with other external memories or peripheral components too. All microcontroller signals are accessible on the BGA connector.

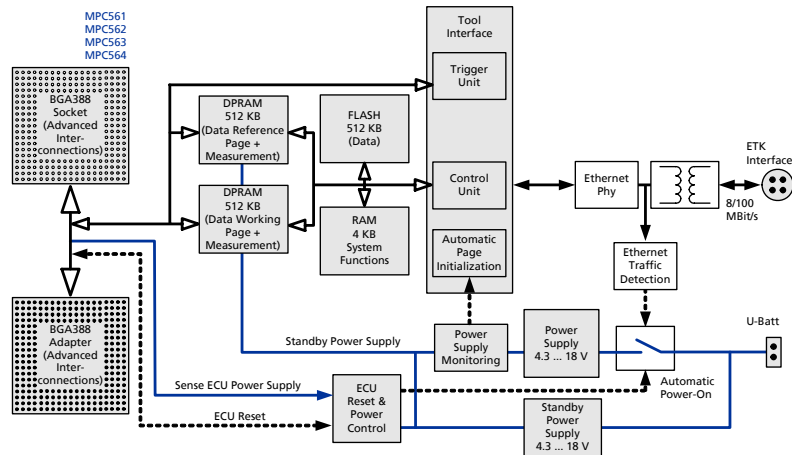

Fig. 3-1 ETKP7.0 Architecture

While the microcontroller accesses the program data (not the program code) out of the data emulation memory, the content of the data emulation memory can simultaneously be modified by the calibration and development system through the serial ETK-interface. This process enables adjustments of parameters, characteristic lines and maps through the calibration and development system. Using an additional measurement data memory area, the ECU microcontroller can send data to the calibration and development system which receives, buffers and processes this measured data.

A flash memory is available for permanent storage of the adjusted parameters (program data).

The 8/100 Mbit/s serial interface provides communication with the calibration and development system.

The ETKP7.0 uses a 3.3 V technology. The power supply for the ETKP7.0 is provided by a switch mode power supply, to minimize power dissipation.

3.2 Microcontroller Interface

The whole microcontroller interface to the calibration and development system memories has a 16 bit wide data bus and uses only one chip select for read and write accesses.

The microcontroller can read and write its data directly from or to the data emulation and measurement data memory. Fig. 3-2 "System with internal and external Memory" shows an overview of the system with "on chip" Flash and RAM and external Flash and RAM memory.

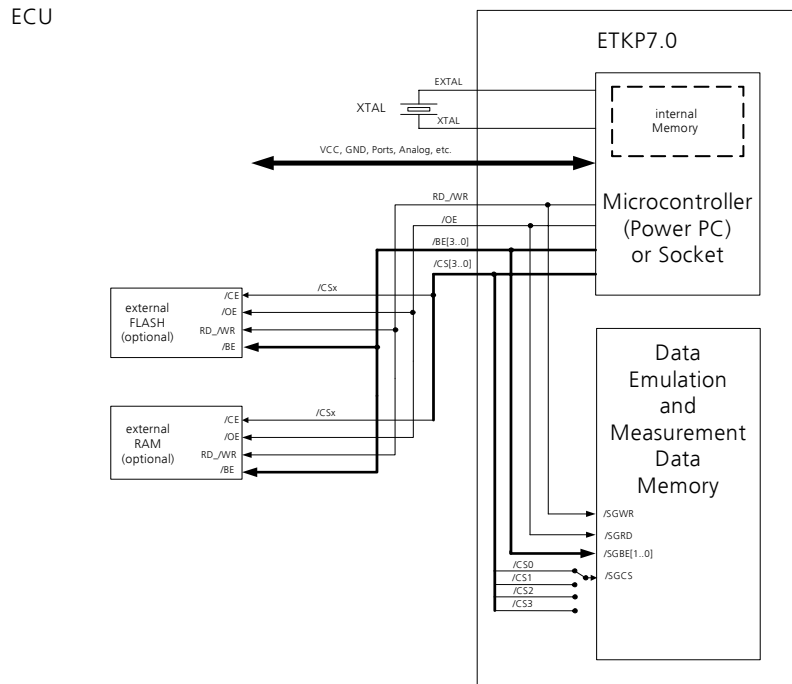

Fig. 3-2 System with internal and external Memory

It also shows the possibilities to access the different memories with its chip selects. The chip select of the data emulation and measurement data memory can be chosen (/CS0, /CS1, /CS2 or /CS3) by soldering the respective bridge on the PCB (see chapter 3.10 "Chip Select Configuration Bridge").

3.3 BGA Connector

The BGA connector interfaces the microcontroller with the ECU. All signals of the microcontroller are directly connected to the BGA connector. Also the clock signal must be provided through the connector to the microcontroller.

3.4 Data Emulation and Measurement Data Memory

The complete data emulation and measurement data memory consists of two 512 kByte pages (Fig. 3-3 "Data Emulation and Measurement Data Memory: 2 Pages with 512 kByte each"). The address range of the used chip select to address the data emulation and measurement memory must be 512 kByte and it must be defined at a 512 kByte limit.

Data emulation memory and measurement data memory must be located inside this 512 kByte address range. The segmentation of this address range between both memory parts is variable. So the measurement data memory and data emulation memory can have variable size and offset addresses inside this fixed address range.

3.4.1 Data Emulation Memory

During operation of an ECU, only program data, not program code, can be modified by using the data emulation memory. Modification of program code would inevitably lead to a system crash. The program code is continuously processed out of the internal or external memory. Freescale controllers support this concept.

Reference data can be stored on one page ("Reference page") while the data on the other page ("Working page") can be modified. It is possible to switch between the two pages during operation through the application software.

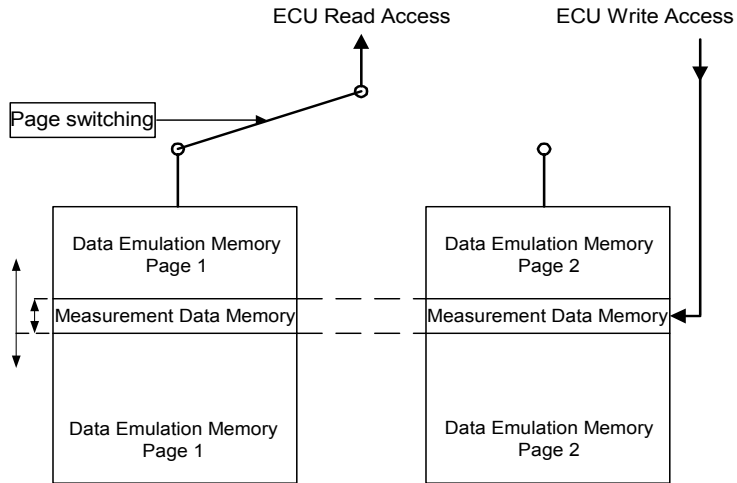

Fig. 3-3 Data Emulation and Measurement Data Memory: 2 Pages with 512 kByte each

3.4.2 Measurement Data Memory

The measurement data memory must be located within the address space of the data emulation and measurement data memory. It can have variable size.

The measured data stored here can be transferred to the calibration and development system via the serial ETK interface.

Note

Because there is no write protection of the data emulation memory possible, it must be taken care not to override emulation data.

3.4.3 Triggering of Measurement Data Capture

The exact procedure for capturing measured data is explained in the documentation Display Tables 12 and 13; only the hardware-specific features are mentioned here. The ETKP7.0 contains a trigger comparator which selects a segment of 64 Byte out of the measurement data memory address space (at a

64 Byte limit). This limit is known as the trigger segment address. Fig. 3-4 "Division of the 64 Byte Trigger Segment" shows the configuration of the 64 Byte trigger segment.

3Eh	trigger 16
3Ch	trigger 15
3Ah	trigger 14
38h	trigger 13
36h	trigger 12
34h	trigger 11
32h	trigger 10
30h	trigger 9
2Eh	trigger 8
2Ch	trigger 7
2Ah	trigger 6
28h	trigger 5
26h	trigger 4
24h	trigger 3
22h	trigger 2
20h	trigger 1
	RESERVED
0Ah	
08h	no Flash->DPR
	RESERVED
02h	ETK_Disable
00h	ETK_Enable

Fig. 3-4 Division of the 64 Byte Trigger Segment

Within the basic and the compatibility trigger mode are only two trigger addresses available: trigger B and trigger A. The ES1232 board for the ES1000.2 system and the ES690 module will support several triggers. To achieve downward compatibility, odd-numbered triggers have been put into group trigger B and the even-numbered triggers into group trigger A. Within the advanced trigger mode 16 hardware triggers will be available.

Note

The unused address areas are reserved for future applications and must not be used for other purposes.

3.4.4 Data Retention in Data Emulation Memory

The data emulation and measurement data memory physically consists of a static Dual Port RAM and is permanently supplied with power from the car battery, to guarantee that data is preserved even when the ignition is switched off. If the ECU with ETK is isolated from the battery, all data will be lost. For brief power interruptions, e.g. during a cold start procedure, buffering is guaranteed through capacitors for several milliseconds.

3.4.5 ETKP7.0 Deactivation

It can be necessary that the ETK does not respond to read or write accesses of the microcontroller. Therefore the microcontroller can switch off the ETKP7.0 chip select. To indicate to the calibration and development system that the microcontroller has "switched on" or "switched off" the ETK a write access before switching off the ETK and after switching on the ETK to the trigger segment (see Fig. 3-4 "Division of the 64 Byte Trigger Segment") must occur.

Through writing to the address ETK_Disable (trigger segment address + 0x02h) the "switching off" will be indicated. Through writing to the address ETK_Enable (trigger segment address) the reactivation of the ETK will be indicated. The data used during the write accesses are meaningless.

Note

These two addresses are not protected against accidental write access. Due to the fact that they belong to the trigger segment, they are allocated in the address space of the measurement data memory.

3.5 Data Flash Memory

Flash memory is provided on the ETKP7.0 for permanent storage of emulation data. Users can copy the contents of the data emulation and measurement data memory into the flash memory using the operating software. It is recommended that an updated data set is always stored in the flash memory.

The ETKP7.0 has a circuit which recognizes and stores power failures. If this circuit detects a longer power failure, and therefore a possible inconsistency of the emulation data, the ETK controller initiates a copying procedure Flash memory → DPR upon restart. The Flash memory data is copied to both emulation pages. A green LED on the ETK displays the procedure. The operating software announces the procedure by a message in the status line.

If the ETKP7.0 is used as a normal RAM it may be useful that this copying procedure is switched off. This can be done by doing a write cycle to a dedicated address in the trigger segment (trigger segment address + 0x08h, see Fig. 3-4 "Division of the 64 Byte Trigger Segment"). The green LED on the ETK will be switched off.

Note

The Flash memory on the ETKP7.0 only stores data which exists in the data emulation and measurement data memory of the ETKP7.0. The program code is stored only in the ECU Flash memory.

3.6 Code Flash Memory

The program code is not emulated by the ETKP7.0. The program code is stored in the ECU Flash memory ("on chip" and/or external) and is not modified by the ETKP7.0. Only the accessible emulation data areas are emulated by the ETKP7.0. The ECU Flash memory can be programmed with the normal Flash memory programming tools.

3.7 Power Supply

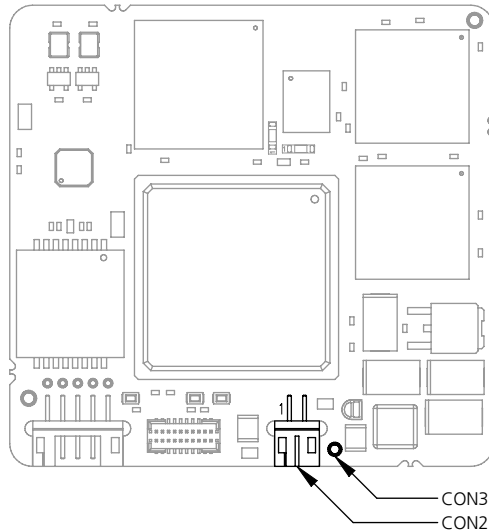

Fig. 3-5 Power Supply Connectors

The ETKP7.0 is powered directly from the car battery (permanent supply). The input voltage varies between 4.3 V and 18 V.

In case of higher input voltages to the ETK an additional voltage converter is required.

All necessary voltages are created through switch mode power supplies which minimizes heat build-up. The power supply of the ECU is not affected by the ETKP7.0.

An automatic switch ensures that the power supply of the ETKP7.0 is automatically switched on and off.

The ETKP7.0 can be supplied with power through the 2-pin power supply connector and additionally through CON3 a through-hole solder pad to connect a power supply U_{Batt2} . The power supply on CON3 must use the GND of CON2.

The ECU voltage ($U_{\text{VDD2_6}}$) is monitored by the ETK to recognize whether the ECU is switched on or off.

3.8 Serial ETK Interface

The serial 8/100 Mbit/s ETKP7.0 interface creates the link to the calibration and development system. The ES1232 plug-in board for the ES1000 high-end system will support the 100 Mbit/s interface.

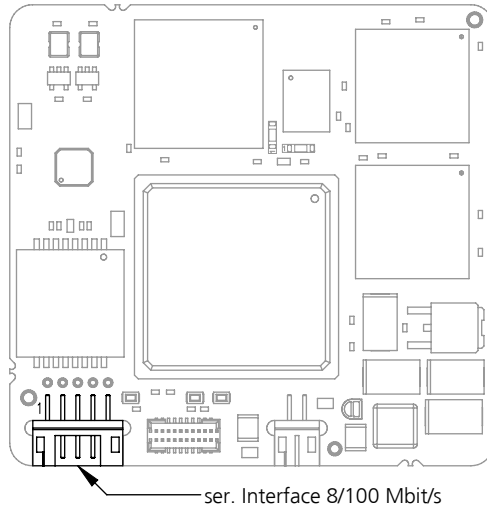

Fig. 3-6 Location of the Serial ETK Interface

The interface utilizes a 100Base-TX transmission to achieve an outstanding transmission performance of 100 Mbit/s. The ETK interface is also able to handle the 8 Mbit/s interface of "old" calibration and development systems. The new interface requires a new shielded twisted-pair cable (maximum length: 30 m). It is not possible to use the old interface cable (for 8 Mbit/s) with the new interface in the 100 Mbit/s mode. The new interface cable can be used with the old interface.

3.9

Status LEDs

There are three LEDs displaying the operating status of the ETKP7.0 (Fig. 3-7 on page 22).

LED	State	Meaning
Red	On	ETKP7.0 is supplied with power and active (i.e. the ECU is switched on or the ETAS calibration and development system is connected and ready to communicate with the ETKP7.0)
Green	On	When the power supply voltage drops below 3.5 V, the data retention of the DPRs is not longer ensured. As soon as the ETK is switched on again, the content of the ETK-Flash will be copied into reference and working page RAM. The green LED stays lit until the calibration and development system copies new data into RAM.
	Off	Working page may be different to reference page. Working page and reference page may be different to the ETK-Flash.
Yellow	On	100 Mbit/s communication to calibration system established

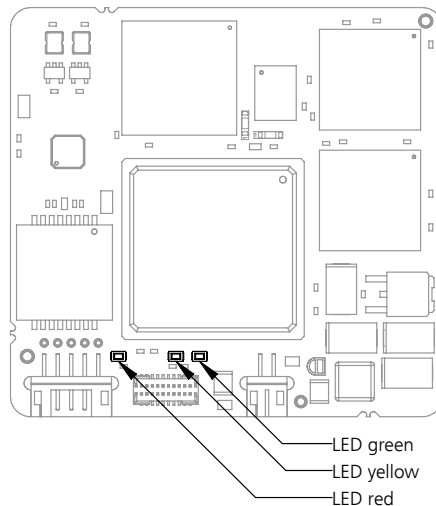

Fig. 3-7 Status LEDs

3.10 Chip Select Configuration Bridge

BR100 and BR101 are solder bridges to configure the used chip select.

BR100	BR101	Chip Select	Default
1 - 2 shortened	Open	/CS0	ETKP7.0-A
2 - 3 shortened	Open	/CS1	-
Open	1 - 2	/CS2	ETKP7.0-K
Open	2 - 3	/CS3	-

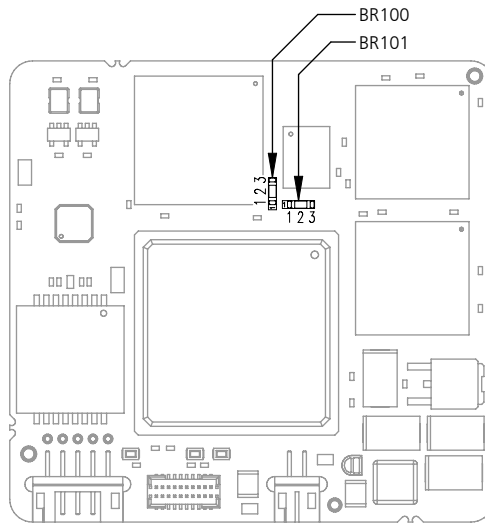

Fig. 3-8 Chip Select Configuration Bridge

4 Installation

In this chapter, the hardware installation of the ETKP7.0 is described.



CAUTION!

Some components of the interface board may be damaged or destroyed by electrostatic discharges. Please keep the board in its storage package until it is installed.

The board should only be taken from its package, configured, and installed at a work place that is protected against static discharge.

4.1 Connection to the ECU

For mounting the ETKP7.0 on the ECU an Advanced Interconnect socket is required. It need to be ordered seperately (refer chapter "Ordering Information" on page 47).

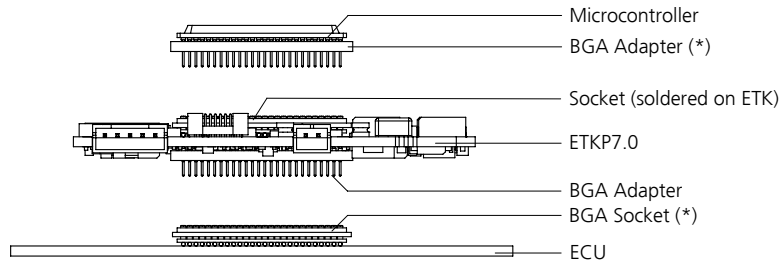

(*) Not delivered with ETK

Fig. 4-1 ETKP7.0 Connection to the ECU

The ETKP7.0 board fitted with a "BGA adapter" connector allows connection and removal from an ECU development PCB which has been fitted with a compatible "BGA receiver" socket (see Fig. 4-1).

4.2 Connecting to the Power Supply

The ETKP7.0 needs a permanent power supply (refer chapter "Power Supply" on page 20). There are different versions to ensure it.

Note

Filter coils for EMC reduction are added to power supply of ETKP7.0 (on board). It means that the ETV2 cable is not required for this and following ETKP7.0 hardware versions.

4.2.1 Permanent Power Supply inside ECU available

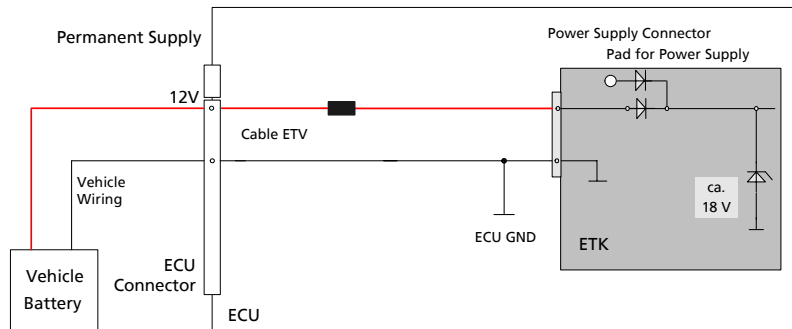

Fig. 4-2 Permanent Power Supply inside ECU available

4.2.2 Permanent Power Supply inside ECU not available

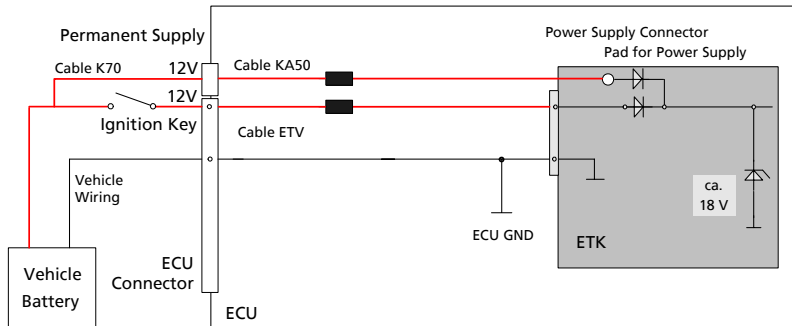

Fig. 4-3 Permanent Power Supply inside ECU not available

4.2.3 Isolated Power Supply inside ECU

The ETKP7.0 does not require a galvanically isolated power supply. For special applications ETAS offers the isolated power supply ETP2.

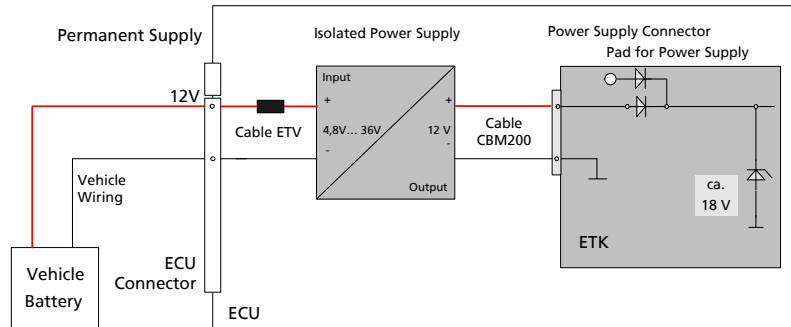

Fig. 4-4 Isolated Power Supply inside ECU

5 ETK Configuration

In this chapter, the configuration parameters of the ETKP7.0 are described.

5.1 Overview

As already mentioned in previous chapters, some project-specific adjustments are necessary. Configuration data is stored permanently in a serial E²PROM. Generating a valid configuration data set is supported by the "ETK Configuration Tool". The "ETK Configuration Tool" contains information on all available ETKs. The user is supported through a graphical interface.

5.2 ETK Configuration Tool

Generating a valid configuration data set is supported by the "ETK Configuration Tool". The "ETK Configuration Tool" contains information on all available ETKs. The user is supported through a graphical interface.

The configuration is done in two steps:

1. Generation of the special address offset for the emulation and measurement data memory.

The location of data areas, measured data output areas, trigger segment addresses etc. are familiar to the ECU software developer, or can be generated automatically. If an ECU description database (ASAP, ...) with the corresponding input exists, these inputs can be downloaded from this database. If necessary, a plausibility check is performed.

2. Connection of the ETK to the ECU.

The ECU hardware developer defines the connection of the ETK to the ECU. The corresponding signals usually have to be adjusted for each microcontroller. All inputs are checked for plausibility, to make sure that a valid configuration is generated.

The "ETK Configuration Tool" can create the following output:

1. Direct ETK configuration
2. Storage of the configuration in a data file
3. The corresponding ASAP input

The most important outputs are the entries for the ASAP file. The parameter ETK_CFG is created and contains the complete ETK configuration of the ECU interface in hex code. If this parameter is entered correctly in the corresponding ECU description file, it guarantees that every time the calibration system is started, the ETK is checked for the appropriate configuration. If necessary, the ETK will be configured appropriately to the corresponding project.

5.3 Configuration Parameter

The configuration of the ETKP7.0 is possible with the "ETK Configuration Tool". Not all combinations of parameters make sense. The "ETK Configuration Tool" provides support concerning the configuration parameters.

6 Technical Data

6.1 General Information

6.1.1 Described ETKP7.0 Hardware State

A sticker on the top of the ETKP7.0 allows you to indicate the ETKP7.0 PCB revision, if you use the hardware state syntax.

Hardware state syntax	Meaning
aabccc/dd	"b" indicates the PCB revision

Note

This manual describes the ETKP7.0, PCB revision "E" and up.

6.1.2 Measurement Conditions

Note

The electrical characteristics of this ETKP7.0 version are unchanged to previous ETKP7.0 versions. The values of the electrical characteristics differ because of different measurement conditions.

6.2 System Requirements

6.2.1 Software Support

You need following software versions to support the ETKP7.0:

Software	Version (or higher)
HSP (Firmware)	2.0
INCA	4.0.2
ASCET-SD	4.1.2 and TIPEX V4.3.0 (INCA V4.0.2 is required when RP and MC runs parallel)
INTECRIO	1.0

6.2.2 Hardware

Required ETAS Hardware

Following ETAS hardware with ETK interface supports the ETKP7.0:

Hardware	Boards/Modules
VME-Hardware	ES1000.2/ES1000.3 with ES1120 and ES1200/ ES1201
	ES1000.2/ES1000.3 with ES1120 and ES1231
	ES1000.2/ES1000.3 with ES1232
Compact Hardware	ES690
	ES590, ES591
	ES910.2
	MAC2F

Not supported ETAS Hardware

Following ETAS hardware with ETK interface **not** supports the ETKP7.0:

Hardware	Boards
VME hardware	ES1000.1 with ES1111 and ES1200/ES1201

6.3 Supported Microcontroller

Item	Characteristics
Supported microcontrollers	Freescale MPC561/562, MPC563/564

6.4 Configuration

Item	Characteristics
Configuration	Project-specific configuration for memory configurations stored in EEPROM
Update	Logic devices updated through software

6.5 Serial ETK Interface

Item	Characteristics
Transmission performance	8 Mbit/s, 100 Mbit/s
Cable type	Shielded twisted-pair
Cable length	max. 30 m / 100 ft
Serial Interface	DC decoupling

6.6 Power Supply

Parameter	Symbol	Condition ¹⁾	Min	Typ	Max	Unit
Permanent Power Supply	U_{Batt1} , U_{Batt2}		4.3	12	18	V
Standby Current	I_{STBY}	$U_{\text{Batt}} = 12 \text{ V}$; ECU off; $T = 20 \text{ }^\circ\text{C}$	0.1	10	30	mA
Operating Current	I_{Batt}	$U_{\text{Batt}} = 12 \text{ V}$; ECU on; $T = 20 \text{ }^\circ\text{C}$, 100 Mbit/s	20	75	100	mA
ECU Power Supply Supervision Voltage	U_{VDD2_6}	$U_{\text{VDD2}_6} \uparrow$	1.91	2.01	2.11	V
		$U_{\text{VDD2}_6} \downarrow$	1.86	1.96	2.06	V
	I_{VDD2_6}				100	μA

¹⁾: $U_{\text{VDD2}_6} \uparrow$: ECU Power Supply off → ECU Power Supply on
 $U_{\text{VDD2}_6} \downarrow$: ECU Power Supply on → ECU Power Supply off

6.7

Testcharacteristics

Parameter	Symbol	Condition	Min	Max	Unit
Reset delay 1	t_{Reset1}	$U_{\text{Batt1}}=12\text{ V}$ $U_{\text{VDD2_6}}=0\text{ V} \uparrow 2.6\text{ V}$ without transferring Flash	15	35	ms
Reset delay 2	t_{Reset2}	$U_{\text{Batt1}}=12\text{ V}$ $U_{\text{VDD2_6}}=0\text{ V} \uparrow 2.6\text{ V}$ with transferring Flash	28	48	ms
Reset delay 3	t_{Reset3}	$U_{\text{Batt1}}=0\text{ V} \uparrow 12\text{ V}$ transfer FPGA and Flash	228	518	ms

t_{Reset1} : Delay of ECU reset through ETK without transferring the Flash
(U_{Batt1} present, $U_{\text{VDD2_6}}$ will be switched on)

t_{Reset2} : Delay of ECU reset through ETK with transferring the Flash
(U_{Batt1} present, transfer active, $U_{\text{VDD2_6}}$ will be switched on)

t_{Reset3} : Max. delay of ECU reset through ETK
(U_{Batt1} and $U_{\text{VDD2_6}}$ will be switched on)

Signal	Pin Type	V_{OL} (max) [V]	V_{OH} (min) [V]	V_{OH} (max) [V]	V_{IL} (max) [V]	V_{IH} (min) [V]	V_{IH} (max) [V]	Leakage current [μ A]	Additional Load by ETK (typ) [pF] ³⁾
ADDR[30..13]	I	-	-	-	0.8	2	3.45	-30/ +30	40
DATA	I/O	0.4	2.4	3.3	-	-	3.45	-20/ +20	30
RD_WR	I	-	-	-	0.8	2	3.45	-30/ +30	35
/OE	I	-	-	-	0.8	2	3.45	-570/ -520	45
/WE_AT[1..0]	I	-	-	-	0.8	2	3.45	-30/ +30	35
/CS[3..0]	I	-	-	-	0.8	2	3.45	0 ¹⁾ -30/ +30 ²⁾	0.8 ¹⁾ 35 ²⁾
/HRESET	I	-	-	-	0.8	1.7	5.75	-10/ +10	15
/PORESET	I/O	0.4	-	-	0.8	1.7	5.75	-10/ +10	35

¹⁾ /CS[3..0] not used

²⁾ /CS[3..0] used

³⁾ BGA connector not considered; PCB 1pF/cm

Note

*:/PORESET: opendrain FET; $I_{Dmax} = 0.2 A$

Capacitance only with ETK-logic, without microcontroller, PCB and BGA socket.

6.9 Switching Characteristics

The following diagrams show the timings the ETKP7.0 can process.

Para.	Description	Min	Max	Unit
t ₄	Access Cycle Time	20		ns
t ₆	Chip Select Valid to Data Valid		20	ns
t ₉	Address Valid to Data Valid		20	ns
t ₁₀	Read Low to Data Valid		12	ns
t ₁₁	Read Low Z-Time	3		ns
t ₁₂	Read High Z-Time		12	ns
t ₁₆	Chip Select Setup Time	0		ns
t ₁₇	Chip Select Hold Time	0		ns
t ₂₁	Address Valid to End of Write	16		ns
t ₂₂	Data Setup Time	12		ns
t ₂₃	Data Hold Time	0		ns
t ₂₄	Read/Write Setup Time	0		ns
t ₂₅	Read/Write Hold Time	0		ns
t ₃₁	Byte Enables Setup Time	0		ns
t ₃₂	Byte Enables Width	17		ns
t ₃₃	Byte Enables Hold Time	0		ns
t ₄₆	Chip Select Invalid to High Z-Time		12	ns
t ₄₇	Byte Enables Valid to Data Valid		20	ns
t ₄₈	Byte Enables Invalid to High Z-Time		12	ns

Note

All timings are measured at a reference level of 1.5 V. Output signals are measured with 10 pF to ground and 50 Ω to 1.5 V.

6.9.1 Read Timing: Data Emulation and Measurement Data DPR

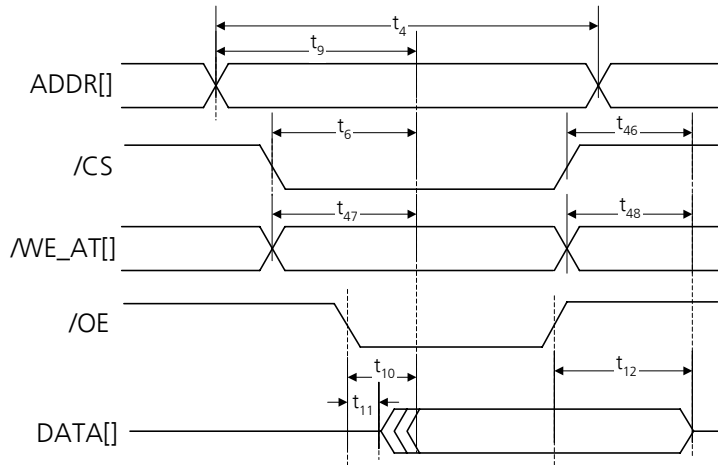

Fig. 6-1 Read Cycle: Data Emulation and Measurement Data DPR

6.9.2 Write Timing: Data Emulation and Measurement Data DPR

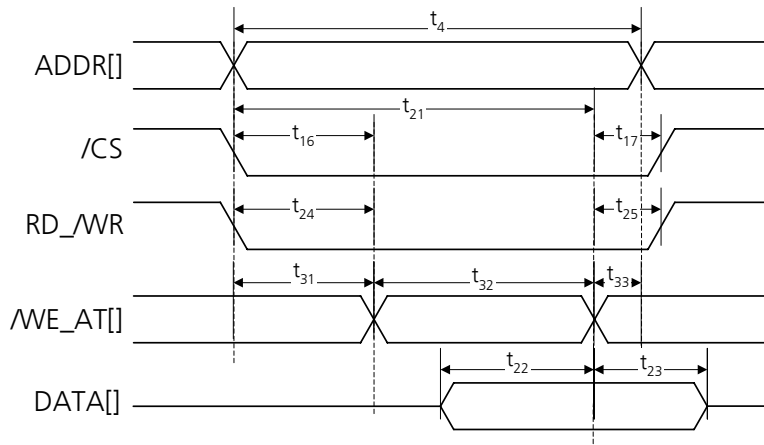

Fig. 6-2 Write Cycle: Data Emulation and Measurement Data DPR

6.10 Environmental Conditions

Item	Characteristics
Temperature range	- 40 °C to +110 °C - 40 °F to +230 °F

6.11 Pin Assignment

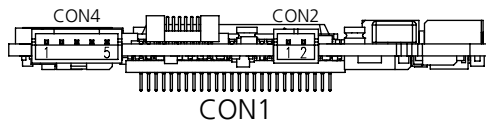

Fig. 6-3 Power Supply Connector CON2

Pin CON2	Signal	Description
1	U_{Batt1}	Battery Supply Voltage for ETK
2	GND	Ground

6.12 Mechanical Dimensions

6.12.1 General Dimensions

The reference measure for all drawings is millimeter.

Dimensions	Millimeters	Inches
Length	64.00	2.520
Width	61.00	2.402
Thickness of PCB	1.70	0.067
Height of component (upper side)	3.00	0.118
Height of component (lower side)	2.00	0.079

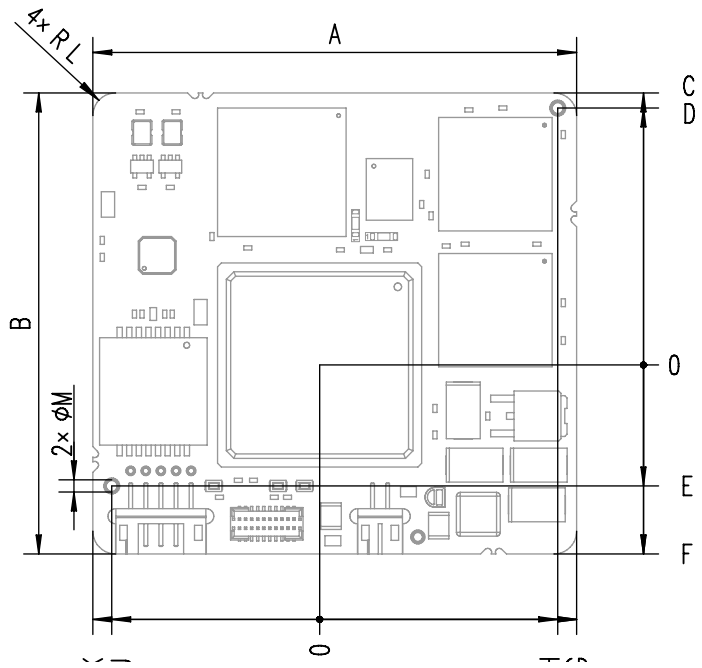

Fig. 6-4 ETKP7.0 Dimensions - Top View

Dim	Millimeters	Inches	Dim	Millimeters	Inches
A	64.00	2.520	G	34.00	1.339
B	61.00	2.402	H	31.00	1.240
C	36.00	1.417	J	27.50	1.083
D	34.00	1.339	K	30.00	1.181
E	16.00	0.630	L	3.00	0.118
F	25.00	0.984	M	1.50	0.059

6.12.2 Microcontroller with BGA Adapter and Socket mounted

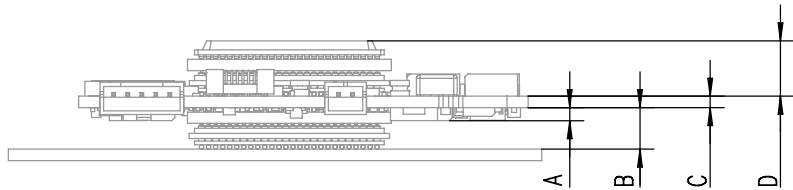

Fig. 6-5 Microcontroller with BGA Adapter and Socket mounted

Dim	Millimeters	Inches
A	2.00	0.079
B	5.77	0.227
C	1.70	0.067
D	7.71	0.303

6.12.3 Microcontroller soldered on ETK

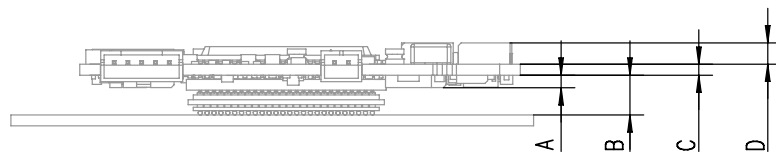

Fig. 6-6 Microcontroller soldered on ETK

Dim	Millimeters	Inches
A	2.00	0.079
B	5.77	0.227
C	1.70	0.067
D	3.00	0.118

7 Cables

7.1 Interface Cables

7.1.1 Interface Cable KA54 with PG Cable Gland

Note

The screws for mounting cables KA54 showed in chapter "Interface Cable KA54 with PG Cable Gland" on page 41 are not included in the KA54 delivery. They need to be ordered separately. For screw manufacturers and order numbers refer to the description of the cables.

Interface Cable KA54 with PG Cable Gland, Proposal 1

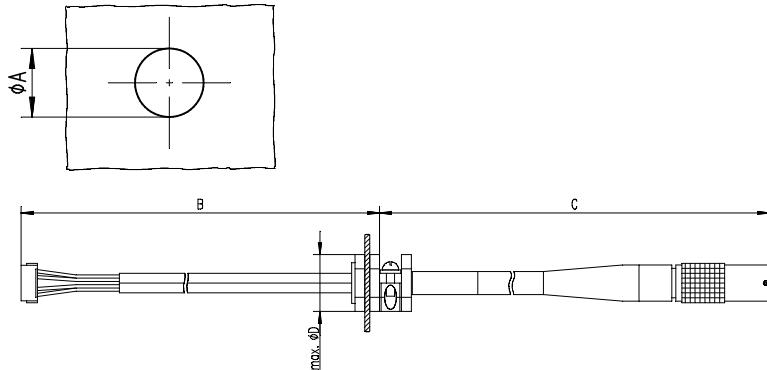

Fig. 7-1 Interface Cable KA54, Prop. 1

Dim	Millimeters	Inches	Dim	Millimeters	Inches
A	12.50	0.492	C	400.00	15.748
B	160.00	6.299	D	19.00	0.748

Note

Shield connected to ECU housing.

SKINDICHT compact screwing; **Manufacturer:** Lapp; **Description:** SH7; **Order-No.:** 5200 0830

Nut for compact screwing; **Manufacturer:** Lapp; **Description:** SM7;
Order-No.: 5200 3490

Interface Cable KA54 with PG Cable Gland, Proposal 2

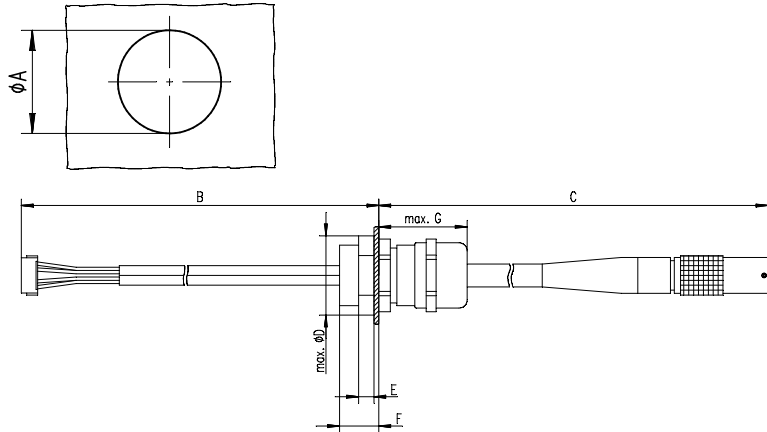

Fig. 7-2 Interface Cable KA54, Prop. 2 (long thread)

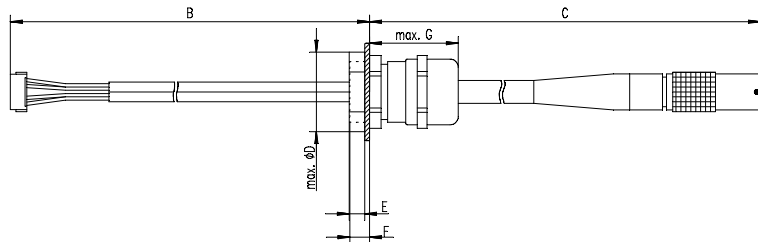

Fig. 7-3 Interface Cable KA54, Prop. 2 (short thread)

Dim	Millimeters	Inches	Dim	Millimeters	Inches
A	18.80	0.740	E	4.70	0.185
B	160.00	6.299	F_{Long}	12.00	0.472
C	400.00	15.748	F_{Short}	6.00	0.263
D	24.25	0.955	G	27.00	1.063

Note

Shield connected to ECU housing.

SKINTOP compact screwing; **Manufacturer:** Lapp; **Description:** MS-SC 11 ;
Order-No.: 5311 2320 (long thread) or 5311 2220 (short thread)

Nut for compact screwing; **Manufacturer:** Lapp; **Description:** SM-PE 11 ;
Order-No.: 5210 3220

7.1.2 Interface Cable KA55

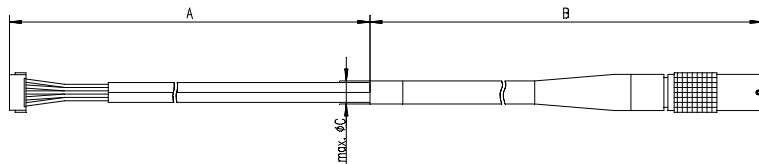

Fig. 7-4 Interface Cable KA55

Dim	Millimeters	Inches
A	160.00	6.299
B	400.00	15.748
C	7.50	0.295

Note

Strain relief on ECU cover necessary. Shield not connected to ECU housing.

7.2 Power Supply Cables

7.2.1 Cable ETV

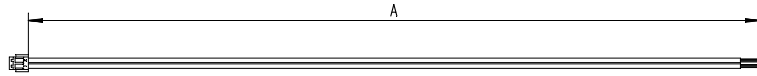

Fig. 7-5 Power Supply Cable ETV

Dim	Millimeters	Inches
A	190.00	7.480

7.2.2 Cable K70

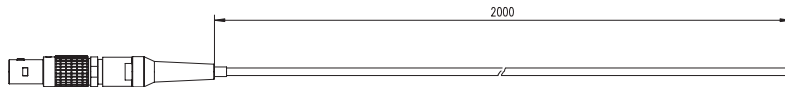

Fig. 7-6 Power Supply Cable K70

Dim	Millimeters	Inches
A	2000	78.74

7.2.3 Cable KA50

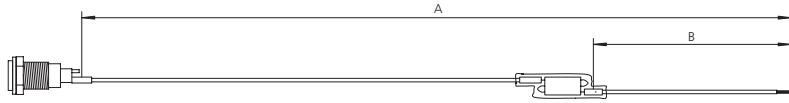

Fig. 7-7 Power Supply Cable KA50

Dim	Millimeters	Inches
A	200	7.87
B	50	1.97

7.2.4 Cable CBM200

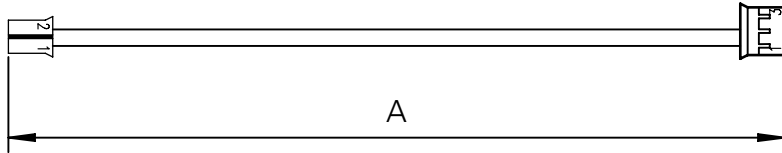

Fig. 7-8 Power Supply Cable CBM200

Dim	Millimeters	Inches
A	100	3.94

8 Ordering Information

8.1 ETKP7.0

Type	Order-No.	Note
ETKP7.0-A	F 00K 103 197	ETKP7.0 with /CS0 as default memory chip select; (micromcontroller to be supplied by customer)
ETKP7.0-K	F 00K 103 199	ETKP7.0 with /CS2 as default memory chip select; (micromcontroller to be supplied by customer)

Note

Some of the BGA sockets and adapters are not included in ETKP7.0 delivery (refer to "Connection to the ECU" on page 25). They need to be ordered separately (refer chapter "Ordering Information" on page 47).

8.2 Sockets

Note

For mounting the ETK on the ECU, one of the following Advanced Interconnect Sockets must be used. Please do not use other sockets.

Type	Note
Advanced Interconnect Socket (7112TR)	Available from local Advanced Interconnect distributors
Advanced Interconnect BGA Socket for MPC5xx (1FHS388-716GG)	Available from local Advanced Interconnect distributors

8.3 Adapters

Note

For mounting the microcontroller on the ETK the following Advanced Interconnect Adapter must be used. Please do not use other adapters.

Type	Note
Advanced Interconnect BGA Adapter for MPC5xx (1FHA388-715G)	Available from local Advanced Interconnect distributors

8.4 Isolated Power Supply

Type	Order-No.	Note
ETP2	F 00K 104 010	

8.5 Cables

Note

The cables showed in chapter "Cables" on page 41 are not included in the ETKP7.0 delivery. They need to be ordered separately.

8.5.1 Interface Cables

Type	Order-No.	Note
KA41, Prop. 1 / Prop. 2	Y 261 A24 729	
KA54, Prop. 1 / Prop. 2	F 00K 001 302	Delivery without PG Cable Gland
KA55	F 00K 001 303	

8.5.2 Power Supply Cables

Type	Order-No.	Note
ETV	Y 261 A24 446	
K70	Y 261 A24 942	External power supply for ETKs (connector)
KA50	F 00K 000 940	External voltage supply cable with jack and filter coil
CBM200-0m1	F 00K 900 052	Cable JST PH - JST PH (2fc-3fc, 0M1)

Document Revision	Description
R2.0.0 EN	<p data-bbox="428 296 995 352">New chapters: "General information", "Installation", "Configuration"</p> <hr/> <p data-bbox="428 363 986 392">Fig. 3.2 on page 14 is changed (/CS1 and /CS3 added)</p> <hr/> <p data-bbox="428 403 1083 491">Yellow LED is added to display the ETKP7.0 operating status "100 Mbit/s communication to calibration system is established" (see chapter 3.9 on page 22)</p> <hr/> <p data-bbox="428 502 1074 560">/CS1 and /CS3 added; new solder bridge to configure the used chip select (see chapter 3.10 on page 23)</p> <hr/> <p data-bbox="428 571 1083 659">Filter coils for EMC reduction are added to power supply of ETKP7.0 (on board). ETV2 cable is not required for this hardware version.</p> <p data-bbox="428 663 1087 721">ETV2 cable is deleted in chapters "Cable" and Ordering Informa- tions".</p> <hr/> <p data-bbox="428 732 1083 788">New measurement conditions for the electrical data (see chapter 6 on page 31).</p>

ETAS HQ

ETAS GmbH

Borsigstraße 14
70469 Stuttgart
Germany

Phone: +49 711 89661-0
Fax: +49 711 89661-105
E-mail: sales@etas.de
WWW: www.etasgroup.com

North America

ETAS Inc.

3021 Miller Road
Ann Arbor, MI 48103
USA

Phone: +1 888 ETAS INC
Fax: +1 734 997-9449
E-mail: sales@etas.us
WWW: www.etasgroup.com

Japan

ETAS K.K.

Queen's Tower C-17F
2-3-5, Minatomirai, Nishi-ku
Yokohama 220-6217
Japan

Phone: +81 45 222-0900
Fax: +81 45 222-0956
E-mail: sales@etas.co.jp
WWW: www.etasgroup.com

Great Britain

ETAS Ltd.

Studio 3, Waterside Court
Third Avenue, Centrum 100
Burton-upon-Trent
Staffordshire DE14 2WQ
Great Britain

Phone: +44 1283 54 65 12
Fax: +44 1283 54 87 67
E-mail: sales@etas-uk.net
WWW: www.etasgroup.com

France

ETAS S.A.S.

1, place des Etats-Unis
SILIC 307
94588 Rungis Cedex
France

Phone: +33 1 56 70 00 50
Fax: +33 1 56 70 00 51
E-mail: sales@etas.fr
WWW: www.etasgroup.com

Korea

ETAS Korea Co. Ltd.

4F, 705 Bldg. 70-5
Yangjae-dong, Seocho-gu
Seoul 137-889
Korea

Phone: +82 2 57 47-016
Fax: +82 2 57 47-120
E-mail: sales@etas.co.kr
www.etasgroup.com

China

ETAS (Shanghai) Co., Ltd.

2404 Bank of China Tower
200 Yincheng Road Central
Shanghai 200120, P.R. China

Phone: +86 21 5037 2220
Fax: +86 21 5037 2221
E-mail: sales.cn@etasgroup.com
WWW: www.etasgroup.com

List of Figures

Fig. 1-1	Standard Safety Symbol	8
Fig. 1-2	WEEE Symbol.....	8
Fig. 2-1	ETKP7.0	11
Fig. 3-1	ETKP7.0 Architecture	13
Fig. 3-2	System with internal and external Memory.....	14
Fig. 3-3	Data Emulation and Measurement Data Memory: 2 Pages with 512 kByte each.....	16
Fig. 3-4	Division of the 64 Byte Trigger Segment	17
Fig. 3-5	Power Supply Connectors	20
Fig. 3-6	Location of the Serial ETK Interface	21
Fig. 3-7	Status LEDs	22
Fig. 3-8	Chip Select Configuration Bridge	23
Fig. 4-1	ETKP7.0 Connection to the ECU.....	25
Fig. 4-2	Permanent Power Supply inside ECU available.....	26
Fig. 4-3	Permanent Power Supply inside ECU not available.....	26
Fig. 4-4	Isolated Power Supply inside ECU.....	27
Fig. 6-1	Read Cycle: Data Emulation and Measurement Data DPR.....	37
Fig. 6-2	Write Cycle: Data Emulation and Measurement Data DPR	37
Fig. 6-3	Power Supply Connector CON2	38
Fig. 6-4	ETKP7.0 Dimensions - Top View	39

Fig. 6-5	Microcontroller with BGA Adapter and Socket mounted	40
Fig. 6-6	Microcontroller soldered on ETK.....	40
Fig. 7-1	Interface Cable KA54, Prop. 1	41
Fig. 7-2	Interface Cable KA54, Prop. 2 (long thread)	42
Fig. 7-3	Interface Cable KA54, Prop. 2 (short thread)	42
Fig. 7-4	Interface Cable KA55	43
Fig. 7-5	Power Supply Cable ETV	44
Fig. 7-6	Power Supply Cable K70	44
Fig. 7-7	Power Supply Cable KA50	45
Fig. 7-8	Power Supply Cable CBM200	45

Index

A

Architecture 13

B

Basic Safety Instructions 7
BGA Connector 15
Blockdiagram 13

C

Cable 41
 Interface 41
 Power Supply 44
Code
 Flash Memory 19
Code Flash Memory 19
Configuration Parameter 30
Correct Use 7

D

Data Emulation Memory 15
Data Flash Memory 18
Data Retention 18

Deactivation 18

E

Environmental Conditions 38
ETAS Contact Addresses 53
ETAS Hardware 32
ETK Configuration 29
ETK Configuration Tool 29

F

Features 11

H

Hardware Description 13

I

Installation 25
Interface
 ETK 21
 Processor 14
 Serial 21
Interface Cable 41

Introduction 11
Isolated Power Supply 27, 48

L

LED 22

M

Measurement Data
 Capture 16
Measurement Data Memory 16
Mechanical Dimension 38
Memory
 Code 19

N

not supported 32

O

Operation
 conventions 10
Ordering Information 47

P

Power Supply 20, 26, 33
Power Supply Cables 49
Power Supply Connector 20
Processor Interface 14
Product Back 8
Product liability disclaimer 7
Program Code 19

R

Read Timing 37
Recycling 8
required 32

S

Safety Instructions, Labeling of 8
Serial ETK Interface 21
Software Support 31
Status LED 22
Structure 9
Supported Microcontroller 12
Switching Characteristic 36
System Requirements 31

T

Timing
 Read 37
 Write 37
Trigger Segment 17
Triggering 16

V

Version History 51

W

Waste Electrical and Electronic Equipment
 8
WEEE 8
WEEE take-back system 8
Write Timing 37