

ETP4

Power supply for ECU

User's Guide



Copyright

The data in this document may not be altered or amended without special notification from ETAS GmbH. ETAS GmbH undertakes no further obligation in relation to this document. The software described in it can only be used if the customer is in possession of a general license agreement or single license. Using and copying is only allowed in concurrence with the specifications stipulated in the contract.

Under no circumstances may any part of this document be copied, reproduced, transmitted, stored in a retrieval system or translated into another language without the express written permission of ETAS GmbH.

© Copyright 2018 ETAS GmbH, Stuttgart

The names and designations used in this document are trademarks or brands belonging to the respective owners.

Document ETP4 R02_EN – 09.2018

Contents

1	About this Manual.....	5
1.1	Identification of Safety Notices.....	5
1.2	Presentation of Information	5
1.3	Scope of Supply.....	6
2	Basic Safety Notices.....	7
2.1	General Safety Information	7
2.2	Requirements for Users and Duties for Operators	7
2.3	Intended Use	7
2.4	Identifications on the Product	9
2.5	Taking the Product Back and Recycling	10
2.6	CE marking	11
2.7	RoHS Conformity	11
2.7.1	European Union.....	11
2.7.2	China	11
3	Introduction.....	12
3.1	View.....	12
4	Technical Data	13
4.1	Connectors	13
4.1.1	CO100 – Ubatt1 in	13
4.1.2	CO101 – Ubatt2 in	13
4.1.3	CO102 – Uout	13
4.2	Installation.....	14
4.2.1	Permanent Power Supply inside ECU available	14
4.2.2	Permanent Power Supply inside ECU not available.....	14
4.3	DC Parameters	14
4.4	Mechanical Drawings.....	16
4.5	Operating Temperature Range	16
5	Ordering Information	17
6	ETAS Contact Addresses.....	18

Figures

Figure 1: Adhesive Label (Example: Label for XETK-S14.0)9

Figure 2: WEEE-Symbol10

Figure 3: View12

Figure 4: Connector Placement HW-Revision AXXX13

Figure 5: Connector Placement HW-Revision AXXX13

Figure 6: Pin Ordering CO10013

Figure 7: JST PHR-2 Connector13

Figure 8: Permanent Power Supply inside ECU available14

Figure 9: Permanent Power Supply inside ECU not available14

Figure 10: Top View HW-Revision AXXX16

Figure 11: Top View HW-Revision BXXX.....16

Figure 12: Side View.....16

1 About this Manual

This chapter contains information about the following topics:

- Identification of Safety Notices on page 5
- Presentation of Information on page 5
- Scope of Supply on page 6

1.1 Identification of Safety Notices

The safety notices contained in this manual are identified with the danger symbol shown below:



The safety notices shown below are used for this purpose. They provide notes to extremely important information. Please read this information carefully.



DANGER!

indicates an immediate danger with a high risk of death or serious injury, if not avoided.



WARNING!

indicates a possible danger with moderate risk of death or (serious) injury, if not avoided.



Caution!

identifies a hazard with low risk that could result in minor or medium physical injuries or property damages if not avoided.

1.2 Presentation of Information

All activities to be performed by the user are presented in a "Use Case" format. That is, the goal to be accomplished is briefly defined in the heading, and the respective steps required for reaching this goal are then presented in a list. The presentation looks as follows:

Goal definition:

any advance information...

- Step 1

Any explanation for step 1...

- Step 2

Any explanation for step 2...

- Step 3

[Any explanation for step 3...](#)

Any concluding comments...

Typographical Conventions

The following typographical conventions are used:

Bold Labels of the device

Italic Particularly important text passages

Important notes for the user are presented as follows:

Note

Important notes for the user.

1.3 Scope of Supply

Prior to the initial commissioning of the module, please check whether the product was delivered with all required components and cables (see chapter "Ordering Information"). Additional cables and adapters can be obtained separately from ETAS. A list of accessories and their order designation is available in this manual and at the ETAS Home Page.

2 Basic Safety Notices

This chapter contains information about the following topics:

- General Safety Information on page 7
- Requirements for Users and Duties for Operators on page 7
- Intended Use on page 7
- Identifications on the Product on page 9"
- Taking the Product Back and Recycling on page 10
- CE marking on page 11
- RoHS Conformity on page 11

2.1 General Safety Information

Please observe the Product Safety Notices ("ETAS Safety Notice") and the following safety notices to avoid health issues or damage to the device.

Note

Carefully read the documentation (Product Safety Advice and this User's Guide) that belongs to the product prior to the startup.

ETAS GmbH does not assume any liability for damages resulting from improper handling, unintended use or non-observance of the safety precautions.

2.2 Requirements for Users and Duties for Operators

The product may be assembled, operated and maintained only if you have the necessary qualification and experience for this product. Incorrect operation or operation by users without sufficient qualification may lead to injuries or death or property damages.

General Safety at Work

The existing regulations for safety at work and accident prevention must be followed. All applicable regulations and statutes regarding operation must be strictly followed when using this product.

2.3 Intended Use

An ETK is an electronic component that is installed in a vehicle control unit (ECU) to read data from the ECU or write data to the ECU.

Application Area of the Product

This product was developed and approved for automotive applications. For use in other application areas, please contact your ETAS contact partner.

Requirements for Operation

The following requirements are necessary for safe operation of the product:

- Use the product only according to the specifications in the corresponding User's Guide. With any deviating operation, the product safety is longer ensured.
- Observe the regulations applicable at the operating location concerning electrical safety as well as the laws and regulations concerning work safety!
- Do not apply any voltages to the connections of the product that do not correspond to the specifications of the respective connection.
- Connect only current circuits with safety extra-low voltage in accordance with EN 61140 (degree of protection III) to the connections of the product.

- The power supply for the product must be safely disconnected from the supply voltage. For example, use a car battery or a suitable lab power supply.
- Use only lab power supplies with double protection to the supply system.
- Ensure that the connections of the power supply are easily accessible.
- The module does not have an operating voltage switch.
 - Switch on the product by connecting the power supply cable with the power supply or by switching on the power supply.
 - Switch off the product by disconnecting it from the power supply or by switching off the power supply.



DANGER!

Connect the power cord only with a vehicle battery or with a lab power supply! A connection to power outlets is prohibited.

- Route the power cord in such a way that it is protected against abrasion, damages, deformation and kinking. Do not place any objects on the power cord.
- Never apply force to insert a plug into a socket. Ensure that there is no contamination in and on the connection, that the plug fits the socket, and that you correctly aligned the plugs with the connection.
- Do not use the product in a wet or damp environment.
- Do not use the product in potentially explosive atmospheres.
- Keep the surfaces of the product clean and dry.

Potential Equalization



Caution!

Danger from inadvertent current flow!

Depending on the design, the shield of the Ethernet cables can be connected with the housing of the module. Install the products only on components with the same electrical potential or isolate the products from the components.

Requirements for the technical State of the Product

The product is designed in accordance with state-of-the-art technology and recognized safety rules. The product may be operated only in a technically flawless condition and according to the intended purpose and with regard to safety and dangers as stated in the respective product documentation. If the product is not used according to its intended purpose, the protection of the product may be impaired.

Maintenance and Cleaning

The product is maintenance-free. Use a lightly moistened, soft, lint-free cloth for cleaning the product. Ensure that no moisture can enter. Never spray cleaning agents directly onto the product. Do not use any sprays, solvents or abrasive cleaners which could damage the product.

Transport and Installation



Caution!

The Product can be damaged or destroyed!

Some components of the ETK board may be damaged or destroyed by electrostatic discharges. Please keep the ETK in its storage package until it is installed. The board should only be taken from its package, configured, and installed at a work place that is protected against static discharge.



Caution!

During installation and removal, ECU and ETK must be in a de-energized state!



Caution!

Risk of short circuiting the internal signals of the Product!

When you mount the Product, you must ensure that the screws and washers used will not penetrate the Product printed circuit board.



Caution!

Differences in case ground potentials can cause high currents to flow through the shields of the cables that connect various system modules.

Ensure that the module mounting surfaces are at the same electrical potential or insulate the modules from their mounting surfaces.

Cabling

Use exclusively ETAS cables at the connections of the product! Adhere to the maximum permissible cable lengths! Observe the assignment of the cables to the connectors! Detailed information about cabling is located in the ETK User's Guides.





2.4 Identifications on the Product



Figure 1: Adhesive Label (Example: Label for XETK-S14.0)

The following symbols are used for identifications of the product:

Symbol	Description
	The User's Guide must be read prior to the startup of the product!

Symbol	Description
	Symbol for WEEE, see chapter 2.5 on page 10
	Symbol for CE conformity, see chapter 2.6 on page 11
	Symbol for China RoHS, see chapter 2.7.2 on page 11
	Symbol for China RoHS, see chapter 2.7.2 on page 11
	Symbol for electrostatic sensitive components
XETK-S14.0A	Product designation (example)
F 00K 110 722	Order number of the product (example)
SN: yyxxxxx	Serial number (7-digit), depending on product Serial Number is not available.
XXXX/YY	Product version
ZZZZ	Year of manufacture
ETAS GmbH, PO Box 300220, 70442 Stuttgart, Germany	Manufacturer's address

Note
For symbols and product information one or several adhesive labels can be used.

2.5 Taking the Product Back and Recycling

The European Union has passed a directive called Waste Electrical and Electronic Equipment, or WEEE for short, to ensure that systems are setup throughout the EU for the collection, treating and recycling of electronic waste. This ensures that the devices are recycled in a resource-saving way representing no danger to health or the environment.



Figure 2: WEEE-Symbol

The WEEE symbol (see Figure 2 on page 10) on the product or its packaging shows that the product must not be disposed of as residual garbage. The user is obliged to collect the old devices separately and return them to the WEEE take-back system for recycling. The WEEE directive concerns all ETAS devices but not external cables or batteries. For more information on the ETAS GmbH Recycling software, contact the ETAS sales and service locations.

2.6 CE marking

With the CE mark attached to the product or its packaging, ETAS confirms that the product corresponds to the applicable product-specific European Directives. The CE Declaration of Conformity for the product is available upon request.

2.7 RoHS Conformity

2.7.1 European Union

The EU Directive 2011/65/EU limits the use of certain dangerous materials for electrical and electronic devices (RoHS conformity).

This product does not contain any of the restricted substances specified in the EU Directive 2011/65/EU or exceeds the maximum concentrations stipulated therein. For individual electronic components used in our products, there are currently no equivalent alternative substances, which is why we make use of the exception 7C-I in Annex III of this Directive.

ETAS confirms that the product corresponds to this directive which is applicable in the European Union.

2.7.2 China

ETAS confirms that the product meets the product-specific applicable guidelines of the China RoHS (Management Methods for Controlling Pollution Caused by Electronic Information Products Regulation) applicable in China with the China RoHS marking affixed to the product or its packaging.

3 Introduction

ETP4 is a Power Supply for ECU application. Output rating is 1,5V at 0,3A with an input voltage range of 4.3V to 18V. An ETV Cable is necessary for connecting UBatt. The ETP4 uses a Step Down Switching Regulator for reducing power dissipation. The Output is Short-Circuid protected.

3.1 View

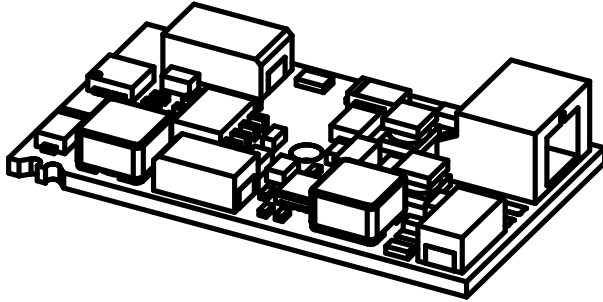

Figure 3: View

4 Technical Data

4.1 Connectors

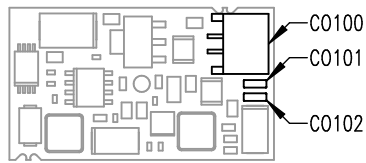

Figure 4: Connector Placement HW-Revision AXXX

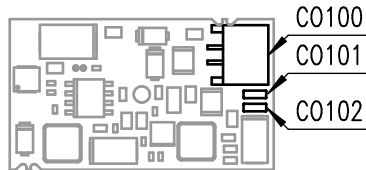

Figure 5: Connector Placement HW-Revision AXXX

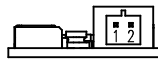

Figure 6: Pin Ordering CO100

4.1.1 CO100 – Ubatt1 in

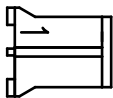

Figure 7: JST PHR-2 Connector

Pin Number	Description
1	UBatt 1
2	GND

Table 1: CO100 pin map

4.1.2 CO101 – Ubatt2 in

Pin Number	Description
Solder Pad	UBatt 2

Table 2: CO101 pin map

4.1.3 CO102 – Uout

Pin Number	Description
Solder Pad	Uout 1.5V

Table 3: CO102 pin map

4.2 Installation

4.2.1 Permanent Power Supply inside ECU available

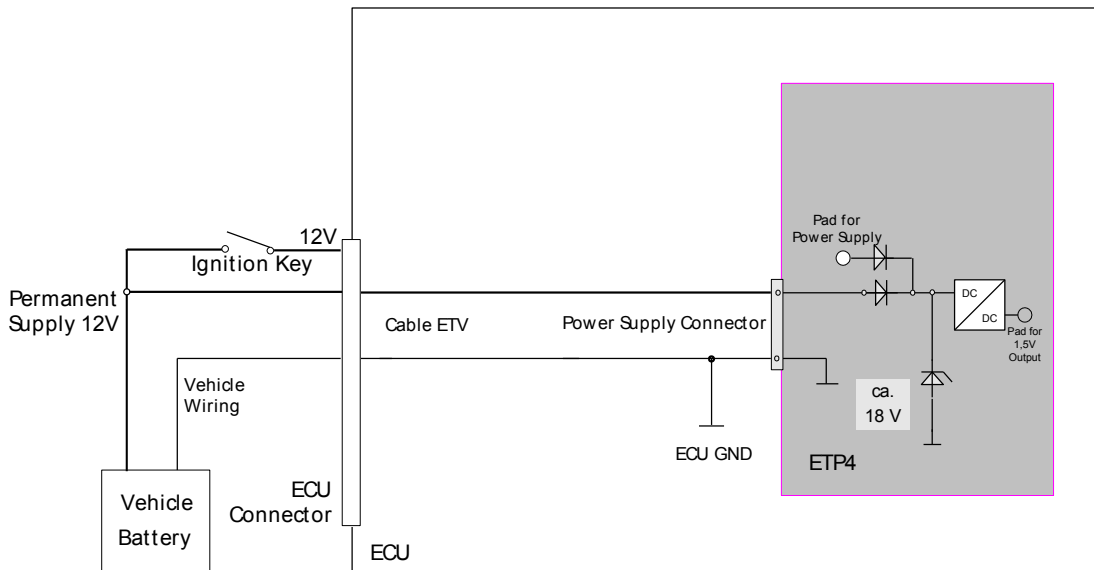

Figure 8: Permanent Power Supply inside ECU available

4.2.2 Permanent Power Supply inside ECU not available

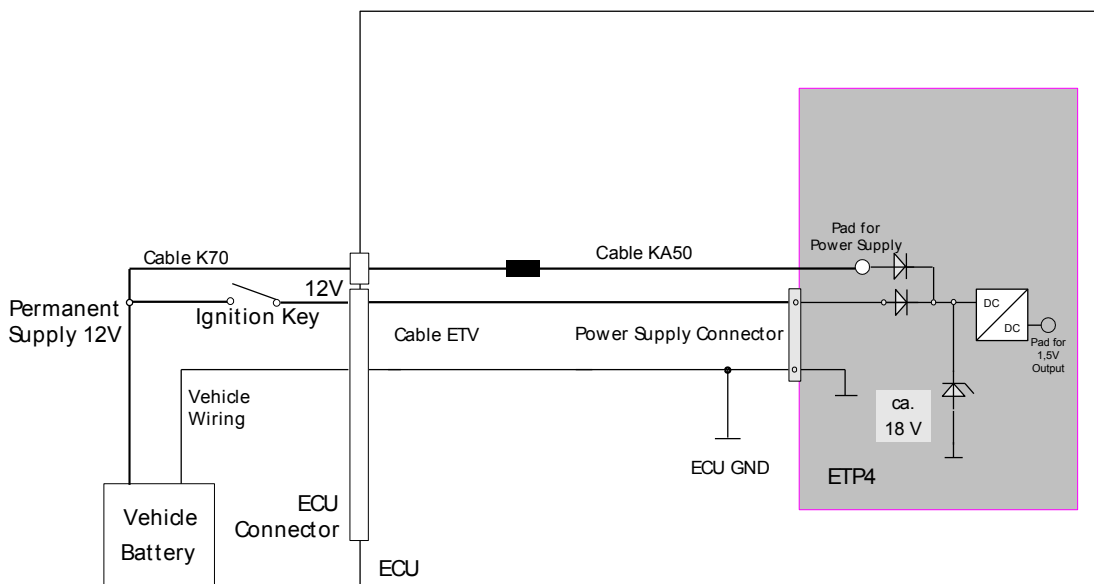

Figure 9: Permanent Power Supply inside ECU not available

4.3 DC Parameters

Parameter	Symbol	Condition	Min	Typ	Max	Unit
Permanent Power Supply (car battery)	Ubatt 1, Ubatt 2		4.3	12	18	V

Parameter	Symbol	Condition	Min	Typ	Max	Unit
Standby Current	Istby	Ubatt = 12V; T = 20°C; no load	0.1	0.6	1.0	mA
Supply Current	Ibatt	Ubatt = 12V; T = 20°C; 300mA load		60		mA
Uout	Uout	load 0 - 300mA	1.44	1.50	1.56	V
Iout	Iout		0		300	mA
Powerup	tup	Ubatt 0V \uparrow 12V Uout up to 1,5V		700		μ s

Table 4: DC Parameters

Note

Output is short-circuit protected against GND with auto restart function.

4.4 Mechanical Drawings

Measurements in mm

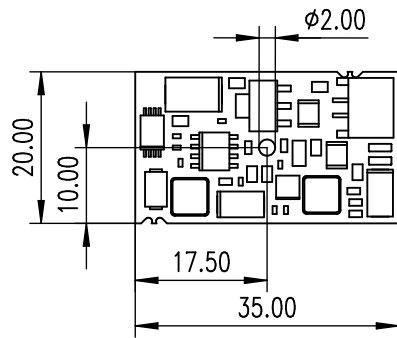

Figure 10: Top View HW-Revision AXXX

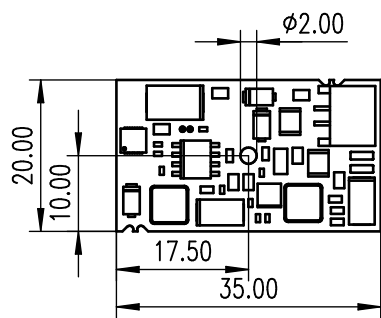

Figure 11: Top View HW-Revision BXXX

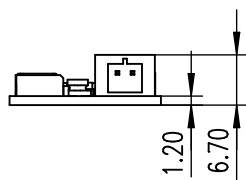

Figure 12: Side View

4.5 Operating Temperature Range

Condition	Temperature
Operating Temperature	-40°C - +110°C

5 Ordering Information

Short Name	Order - Number
ETP4	F 00K 104 914
ETV	Y 261 A24 446

6 ETAS Contact Addresses

ETAS HQ

ETAS GmbH

Borsigstraße 24

70469 Stuttgart

Germany

Phone: +49 711 3423 0

Fax: +49 711 3423 2106

WWW: www.etas.com*ETAS Subsidiaries and Technical Support*

For details of your local sales office as well as your local technical support team and product hotlines, take a look at the ETAS website:

ETAS subsidiaries

WWW: www.etas.com/en/contact.php

ETAS technical support

WWW: www.etas.com/en/hotlines.php