

**XETK-V1.0**  
**Emulator Probe for Freescale MPC5500 Family**  
**using VertiCal Interface**  
User's Guide



## Copyright

---

The data in this document may not be altered or amended without special notification from ETAS GmbH. ETAS GmbH undertakes no further obligation in relation to this document. The software described in it can only be used if the customer is in possession of a general license agreement or single license. Using and copying is only allowed in concurrence with the specifications stipulated in the contract.

Under no circumstances may any part of this document be copied, reproduced, transmitted, stored in a retrieval system or translated into another language without the express written permission of ETAS GmbH.

© **Copyright 2019** ETAS GmbH, Stuttgart

The names and designations used in this document are trademarks or brands belonging to the respective owners.

XETK-V1.0 - User's Guide R1.0.8 EN - 01.2019

---

## Contents

<b>1</b>	About this Manual	6
<b>1.1</b>	Identification of Safety Notices	6
<b>1.2</b>	Presentation of Information	6
<b>1.3</b>	Scope of Supply	7
<b>1.4</b>	Additional Information	7
<b>2</b>	Basic Safety Notices	8
<b>2.1</b>	General Safety Information	8
<b>2.2</b>	Requirements for Users and Duties for Operators	8
<b>2.3</b>	Intended Use	8
<b>2.4</b>	Identifications on the Product	11
<b>2.5</b>	Taking the Product Back and Recycling	12
<b>2.6</b>	CE marking	12
<b>2.7</b>	RoHS Conformity	12
	<b>2.7.1</b> European Union	12
	<b>2.7.2</b> China	12
<b>2.8</b>	Declarable Substances	13
<b>2.9</b>	Use of Open Source Software	13
<b>3</b>	Introduction	14
<b>3.1</b>	Applications	14
<b>3.2</b>	Features	15
<b>4</b>	Hardware Description	17
<b>4.1</b>	VertiCal Interface Concept	17
	<b>4.1.1</b> Overview	17
	<b>4.1.2</b> VertiCal Base Board	18
	<b>4.1.3</b> Typical Usage	18
<b>4.2</b>	Architecture	19
<b>4.3</b>	Microcontroller Interface	20

<b>4.4</b>	VertiCal Connector	21
<b>4.5</b>	Data Emulation and Data Measurement	21
<b>4.5.1</b>	Data Emulation Memory	22
<b>4.5.2</b>	Measurement Data Memory	22
<b>4.5.3</b>	Triggering of Measurement Data Acquisition	22
<b>4.5.4</b>	Data Retention in Data Emulation Memory	24
<b>4.6</b>	Data Flash Memory	24
<b>4.7</b>	Code Flash Memory	24
<b>4.8</b>	Power Supply	25
<b>4.9</b>	XETK Ethernet Interface	27
<b>4.10</b>	Nexus (JTAG) Interface	28
<b>4.11</b>	Status LEDs	29
<b>4.12</b>	Braindead Flashing	30
<b>4.12.1</b>	Braindead Flashing via Nexus (JTAG) Debug Interface	30
<b>4.12.2</b>	External Watchdog disable	31
<b>4.13</b>	Reset	31
<b>5</b>	Installation	32
<b>5.1</b>	Connection to the ECU	32
<b>5.1.1</b>	VertiCal Base Board soldered on ECU PCB	32
<b>5.1.2</b>	VertiCal Base Board mounted on ECU PCB	33
<b>5.2</b>	Wiring	34
<b>5.2.1</b>	XETK Ethernet Interface	34
<b>5.2.2</b>	Power Supply	35
<b>6</b>	XETK Configuration	36
<b>6.1</b>	Overview	36
<b>6.2</b>	Configuration Parameter	36
<b>7</b>	Technical Data	39
<b>7.1</b>	System Requirements	39
<b>7.1.1</b>	ETAS Hardware	39
<b>7.1.2</b>	Ethernet Interface of the PC	39
<b>7.1.3</b>	Software Support	39
<b>7.2</b>	Supported Microcontroller	39
<b>7.3</b>	Environmental Conditions	40
<b>7.4</b>	Power Supply	40
<b>7.5</b>	Configuration	40
<b>7.6</b>	XETK Ethernet Interface	41
<b>7.7</b>	Microcontroller Bus Interface	42
<b>7.8</b>	Testcharacteristics	42
<b>7.9</b>	Electrical Characteristics	43
<b>7.10</b>	Switching Characteristics	47
<b>7.10.1</b>	Read Timing: Data Emulation and Measurement Data DPR	47
<b>7.10.2</b>	Write Timing: Data Emulation and Measurement Data DPR	47
<b>7.11</b>	Mechanical Dimensions	49
<b>7.11.1</b>	XETK-V1.0A	49
<b>7.11.2</b>	XETK-V1.0B	50
<b>7.12</b>	Pin Assignment	52
<b>7.12.1</b>	VertiCal Connector	52

<b>7.12.2</b>	Nexus (JTAG) Connector . . . . .	57
<b>8</b>	Cables and Accessories . . . . .	59
<b>8.1</b>	ECU Adapter Cable . . . . .	59
<b>8.1.1</b>	CBAM230.1 Adapter Cable . . . . .	59
<b>8.1.2</b>	CBAM240.1 Adapter Cable . . . . .	59
<b>8.2</b>	PC Interface Cable . . . . .	60
<b>8.2.1</b>	CBE200-x Cable . . . . .	60
<b>8.2.2</b>	CBAE200.2 Adapter Cable . . . . .	60
<b>8.3</b>	ETAS Module Interface Adapter Cable . . . . .	61
<b>8.3.1</b>	CBE230.1 Cable . . . . .	61
<b>8.3.2</b>	CBAE330.2 Adapter Cable . . . . .	61
<b>8.4</b>	Power Supply Cables . . . . .	61
<b>8.4.1</b>	Cable ETV . . . . .	61
<b>8.4.2</b>	Cable K70 . . . . .	62
<b>8.4.3</b>	Cable KA50 . . . . .	62
<b>8.4.4</b>	Cable CBM200 . . . . .	62
<b>9</b>	Ordering Information . . . . .	63
<b>9.1</b>	XETK-V1.0 . . . . .	63
<b>9.2</b>	VertiCal Base Boards . . . . .	63
<b>9.3</b>	Sockets ECU - VertiCal Base Board . . . . .	64
<b>9.4</b>	Power Supply . . . . .	64
<b>9.5</b>	Cables . . . . .	65
<b>9.5.1</b>	ECU Adapter Cables . . . . .	65
<b>9.5.2</b>	Ethernet Cables . . . . .	65
<b>9.5.3</b>	Power Supply Cables . . . . .	66
<b>10</b>	ETAS Contact Addresses . . . . .	67
	List of Figures . . . . .	68
	Index . . . . .	70

## 1 **About this Manual**

---

This chapter contains information about the following topics:

- „Identification of Safety Notices“ on page 6
- „Presentation of Information“ on page 6
- „Scope of Supply“ on page 7
- „Additional Information“ on page 7

### 1.1 **Identification of Safety Notices**

---

The safety notices contained in this manual are identified with the danger symbol shown below:



The safety notices shown below are used for this purpose. They provide notes to extremely important information. Please read this information carefully.



**DANGER!**

*indicates an immediate danger with a high risk of death or serious injury, if not avoided.*



**WARNING!**

*indicates a possible danger with moderate risk of death or (serious) injury, if not avoided.*



**CAUTION!**

*identifies a hazard with low risk that could result in minor or medium physical injuries or property damages if not avoided.*

### 1.2 **Presentation of Information**

---

All activities to be performed by the user are presented in a "Use Case" format. That is, the goal to be accomplished is briefly defined in the heading, and the respective steps required for reaching this goal are then presented in a list. The presentation looks as follows:

**Goal definition:**

---

any advance information...

- Step 1  
Any explanation for step 1...
- Step 2  
Any explanation for step 2...
- Step 3  
Any explanation for step 3...

Any concluding comments...

### *Typographical Conventions*

---

The following typographical conventions are used:

<b>Bold</b>	Labels of the device
<i>Italic</i>	Particularly important text passages

Important notes for the user are presented as follows:

**Note**

*Important note for the user.*

## 1.3 Scope of Supply

---

Prior to the initial commissioning of the module, please check whether the product was delivered with all required components and cables (see chapter "Ordering Information").

Additional cables and adapters can be obtained separately from ETAS. A list of accessories and their order designation is available in this manual and at the ETAS Home Page.

## 1.4 Additional Information

---

The configuration instructions for the product can be found in the corresponding software documentation.

## 2 Basic Safety Notices

---

This chapter contains information about the following topics:

- "General Safety Information" on page 8
- "Requirements for Users and Duties for Operators" on page 8
- "Intended Use" on page 8
- "Identifications on the Product" on page 11
- "Taking the Product Back and Recycling" on page 12
- "CE marking" on page 12
- "RoHS Conformity" on page 12
- "Declarable Substances" on page 13
- "Use of Open Source Software" on page 13

### 2.1 General Safety Information

---

Please observe the Product Safety Notices ("ETAS Safety Notice") and the following safety notices to avoid health issues or damage to the device.

#### **Note**

*Carefully read the documentation (Product Safety Advice and this User's Guide) that belongs to the product prior to the startup.*

ETAS GmbH does not assume any liability for damages resulting from improper handling, unintended use or non-observance of the safety precautions.

### 2.2 Requirements for Users and Duties for Operators

---

The product may be assembled, operated and maintained only if you have the necessary qualification and experience for this product. Incorrect operation or operation by users without sufficient qualification may lead to injuries or death or property damages.

#### *General Safety at Work*

---

The existing regulations for safety at work and accident prevention must be followed. All applicable regulations and statutes regarding operation must be strictly followed when using this product.

### 2.3 Intended Use

---

An ETK is an electronic component that is installed in a vehicle control unit (ECU) to read data from the ECU or write data to the ECU.

#### *Application Area of the Product*

---

This product was developed and approved for automotive applications. For use in other application areas, please contact your ETAS contact partner.

#### *Requirements for Operation*

---

The following requirements are necessary for safe operation of the product:



- Use the product only according to the specifications in the corresponding User's Guide. With any deviating operation, the product safety is no longer ensured.
- Observe the regulations applicable at the operating location concerning electrical safety as well as the laws and regulations concerning work safety!
- Do not apply any voltages to the connections of the product that do not correspond to the specifications of the respective connection.
- Connect only current circuits with safety extra-low voltage in accordance with EN 61140 (degree of protection III) to the connections of the product.
- The power supply for the product must be safely disconnected from the supply voltage. For example, use a car battery or a suitable lab power supply.
- Use only lab power supplies with double protection to the supply system.
- Ensure that the connections of the power supply are easily accessible.
- The module does not have an operating voltage switch.
  - Switch on the product by connecting the power supply cable with the power supply or by switching on the power supply.
  - Switch off the product by disconnecting it from the power supply or by switching off the power supply.

**DANGER!**

**Connect the power cord only with a vehicle battery or with a lab power supply! A connection to power outlets is prohibited.**

- Route the power cord in such a way that it is protected against abrasion, damages, deformation and kinking. Do not place any objects on the power cord.

- Never apply force to insert a plug into a socket. Ensure that there is no contamination in and on the connection, that the plug fits the socket, and that you correctly aligned the plugs with the connection.

- Do not use the product in a wet or damp environment.

- Do not use the product in potentially explosive atmospheres.

- Keep the surfaces of the product clean and dry.

#### Potential Equalization

---

**CAUTION!**

**Danger from inadvertent current flow!**

Depending on the design, the shield of the Ethernet cables can be connected with the housing of the module. Install the products only on components with the same electrical potential or isolate the products from the components.

#### Requirements for the technical State of the Product

---

The product is designed in accordance with state-of-the-art technology and recognized safety rules. The product may be operated only in a technically flawless condition and according to the intended purpose and with regard to safety and

dangers as stated in the respective product documentation. If the product is not used according to its intended purpose, the protection of the product may be impaired.

#### *Maintenance and Cleaning*

---

The product is maintenance-free. Use a lightly moistened, soft, lint-free cloth for cleaning the product. Ensure that no moisture can enter. Never spray cleaning agents directly onto the product. Do not use any sprays, solvents or abrasive cleaners which could damage the product.

#### *Transport and Installation*

---



#### **CAUTION!**

##### ***The ETK can be damaged or destroyed!***

*Some components of the ETK board may be damaged or destroyed by electrostatic discharges. Please keep the ETK in its storage package until it is installed.*

*The board should only be taken from its package, configured, and installed at a work place that is protected against static discharge.*



#### **CAUTION!**

*During installation and removal, ECU and ETK must be in a de-energized state!*



#### **CAUTION!**

##### ***Risk of short circuiting the internal signals of the ETK!***

*When you mount the ETK to the ECU, you must ensure that the screws and washers used will not penetrate the ETK printed circuit board.*



#### **CAUTION!**

##### ***Differences in case ground potentials can cause high currents to flow through the shields of the cables that connect various system modules.***

*Ensure that the module mounting surfaces are at the same electrical potential or insulate the modules from their mounting surfaces.*

#### *Cabling*

---







Use exclusively ETAS cables at the connections of the product! Adhere to the maximum permissible cable lengths! Observe the assignment of the cables to the connectors! Detailed information about cabling is located in the ETK User's Guides.

2.4 Identifications on the Product



**Fig. 2-1** Adhesive Label (Example: Label for XETK-S14.0)

The following symbols are used for identifications of the product:

Symbol	Description
	The User's Guide must be read prior to the startup of the product!
	Symbol for WEEE, see chapter 2.5 on page 12
	Symbol for CE conformity, see chapter 2.6 on page 12
	Symbol for China RoHS, see chapter 2.7.2 on page 12
	Symbol for China RoHS, see chapter 2.7.2 on page 12
	Symbol for electrostatic sensitive components
XETK-S14.0A	Product designation (example)
F 00K 110 722	Order number of the product (example)
SN: yyxxxxx	Serial number (7-digit)
XXXX/YY	Product version
ZZZZ	Year of manufacture
ETAS GmbH, PO Box 300220, 70442 Stuttgart, Germany	Manufacturer's address

**Note**

*For symbols and product information one or several adhesive labels can be used.*

## 2.5 Taking the Product Back and Recycling

---

The European Union has passed a directive called Waste Electrical and Electronic Equipment, or WEEE for short, to ensure that systems are setup throughout the EU for the collection, treating and recycling of electronic waste.

This ensures that the devices are recycled in a resource-saving way representing no danger to health or the environment.



**Fig. 2-2** WEEE-Symbol

The WEEE symbol (see Fig. 2-2 on page 12) on the product or its packaging shows that the product must not be disposed of as residual garbage.

The user is obliged to collect the old devices separately and return them to the WEEE take-back system for recycling. The WEEE directive concerns all ETAS devices but not external cables or batteries.

For more information on the ETAS GmbH Recycling software, contact the ETAS sales and service locations.

## 2.6 CE marking

---

With the CE mark attached to the product or its packaging, ETAS confirms that the product corresponds to the applicable product-specific European Directives. The CE Declaration of Conformity for the product is available upon request.

## 2.7 RoHS Conformity

---

### 2.7.1 European Union

---

The EU Directive 2011/65/EU limits the use of certain dangerous materials for electrical and electronic devices (RoHS conformity).

This product does not contain any of the restricted substances specified in the EU Directive 2011/65/EU or exceeds the maximum concentrations stipulated therein. For individual electronic components used in our products, there are currently no equivalent alternative substances, which is why we make use of the exceptions 7A and 7C-I in Annex III of this Directive.

ETAS confirms that the product corresponds to this directive which is applicable in the European Union.

### 2.7.2 China

---

ETAS confirms that the product meets the product-specific applicable guidelines of the China RoHS (Management Methods for Controlling Pollution Caused by Electronic Information Products Regulation) applicable in China with the China RoHS marking affixed to the product or its packaging.

## 2.8 Declarable Substances

---

### *European Union*

---

Some products from ETAS GmbH (e.g. modules, boards, cables) use components with substances that are subject to declaration in accordance with the REACH regulation (EU) no.1907/2006.

Detailed information is located in the ETAS download center in the customer information "REACH Declaration" ([www.etas.com/Reach](http://www.etas.com/Reach)). This information is continuously being updated.

## 2.9 Use of Open Source Software

---

The product uses Open Source Software (OSS). This software is installed in the product at the time of delivery and does not have to be installed or updated by the user. Reference shall be made to the use of the software in order to fulfill OSS licensing terms. Additional information is available in the document "OSS Attributions List" at the ETAS website [www.etas.com](http://www.etas.com).

### 3 Introduction

This section contains general safety instructions, information about the basic features and applications of the XETK-V1.0 Interface Board (ETK = Emulator Test Probe), hints to system requirements, and delivery scope.

#### 3.1 Applications

The XETK-V1.0 is an emulator probe especially for the Freescale MPC5500 microcontroller family, e.g. MPC5534, MPC5553 and MPC5554. It combines a typical 16 bit parallel with a serial interface based on the modular Vertical interface concept from Freescale and ETAS.

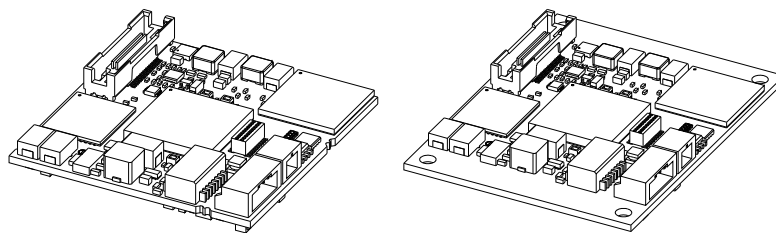

**Fig. 3-1** XETK-V1.0A (left) and XETK-V1.0B (right)

The XETK-V1.0 is an emulator probe for ECU.s with a Nexus (JTAG) debug interface that runs at 3,3 V or below. The XETK-V1.0 offers the opportunity to perform measurement of variables via the Nexus (JTAG) debug interface.

The XETK-V1.0 parallel interface can be used for measurement and calibration. The Nexus (JTAG) interface can be only used for measurement but additionally for flash programming.

The XETK-V1.0 has a direct Ethernet connection to the PC. No additional ETAS modules are required for the access to the ECU.

#### **Note**

*The XETK-V1.0 can be shipped in the two different mechanical versions XETK-V1.0A and XETK-V1.0B (refer to chapter 7.11.1 on page 49 and chapter 7.11.2 on page 50).*

## 3.2 Features

---

- High speed measurement and calibration performance
  - Performance similar to appropriate ETK
  - Hardware synchronization and time stamping
  - Supports fast measurement rasters
- Vertical interface
  - Small form factor
  - Short signal lines for minimal impedance
  - Supports all Freescale MPC5500 microcontroller
  - Applicable for an external Freescale 16-bit microcontroller bus
  - Supports 16- and 8-bit access to the data emulation memory
- Measurement interface
  - Address-/data bus and
  - Nexus (JTAG)
- Measurement memory
  - Two pages of data emulation/measurement data memory available, each with 1 MByte
  - Permanent storage of emulation data in flash memory
  - RAM adaptor mode
  - CPU bus interface voltage 2.5 V/ 3.3 V/ auto sense option
- Trigger interface
  - Trigger direct measurement (TDM)
  - 48 hardware trigger
  - 4 trigger generated by internal timer via Nexus (JTAG)
  - 64 measurement raster
- XCP protocol on Fast Ethernet interface
  - Direct connection to PC
  - Supports a variety of standard applications
- Debugger interface
  - Arbitration possible with power trace
  - Second Nexus (JTAG) compliant Mictor connector for external debug hardware
  - ECU flashing via ETK
  - Brainless flashing under ProF control
- Can drive "Boot configuration" to configure the CPU
- Permanent storage of configuration in Flash
- Configurable ETK chip select
- Enable or disable the ETK by ECU software
- Firmware update (programming of the logic device) through software HSP; removal of XETK or ECU not necessary

For more technical data on the XETK-V1.0 consult the chapter "Technical Data" on page 39.



## 4 Hardware Description

In this chapter, the function blocks of the XETK-V1.0 are explained in detail.

### 4.1 VertiCal Interface Concept

#### 4.1.1 Overview

The VertiCal interface is a new concept to connect the development ECU with an ETK. It uses a microcontroller in a chip scale package (CSP). This chip is fully compatible to the standard microcontroller.

ETKs with VertiCal interface concept can be designed with smaller mechanical dimensions than ETKs with standard interface.

In the VertiCal interface the microcontroller device of the ETK is not mounted on the ETK board, but on an additional board, the VertiCal base board.

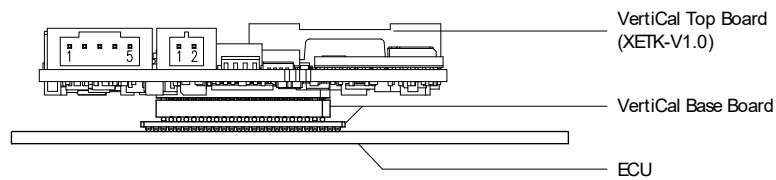

**Fig. 4-1** VertiCal Interface Concept (Side View)

The ETK is mechanically "splitted" and its components are mounted on two different boards:

- the VertiCal base board with
  - a microcontroller in chip scale package (CSP)
  - VertiCal connector (provides access to the ECU microcontroller adapter and the VertiCal top board)
- the VertiCal top board (XETK-V1.0) with
  - Ethernet interface (converts microcontroller signals into tool interface)
  - Nexus (JTAG) interface.

4.1.2 VertiCal Base Board

The printed circuit board (PCB), one of the VertiCal base board components, is used as a base to mount the other components of the VertiCal base board.

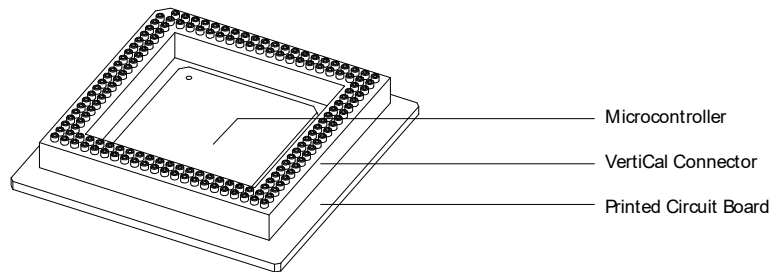

**Fig. 4-2** VertiCal Base Board

The upper side of the printed circuit board is fitted with

- the microcontroller device (packaged into the specified CSP package),
- the VertiCal connector (standardized 156-way connector).

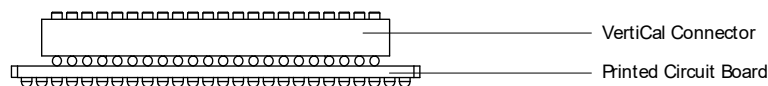
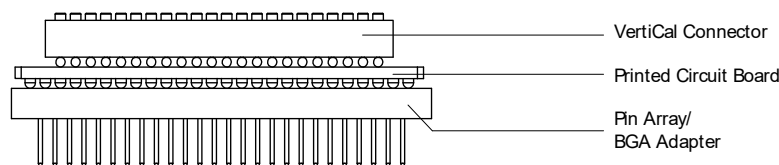

**Fig. 4-3** VertiCal Base Board (fitted with Solder Balls, Side View)

The lower side of the printed circuit board has a footprint similar to that used by MPC5500 family devices in standard production packages.

The lower side of the board is fitted either

- with solder ball footprints for direct and permanent soldered connection to the development ECU PCB (see Fig. 4-3) or
- with a "BGA adapter" connector allowing connection and removal from an ECU development PCB which has been fitted with a compatible "BGA receiver" socket (see Fig. 4-4).



**Fig. 4-4** VertiCal Base Board (fitted with Pin Array/ BGA Adapter, Side View)

4.1.3 Typical Usage

The standard ECU microcontroller is replaced by the VertiCal base board with the same dimensions and the same pinout.

The VertiCal base board connects the ECU with the XETK-V1.0.

## 4.2 Architecture

Fig. 4-5 "XETK-V1.0" shows the block diagram of the XETK-V1.0.

The microcontroller can read via the VertiCal connector from one of the two pages of the data emulation memory and can write its data directly to the measurement data memory. These two memories (data emulation memory, measurement data memory) are using the same address space and are realized inside the same DPRs.

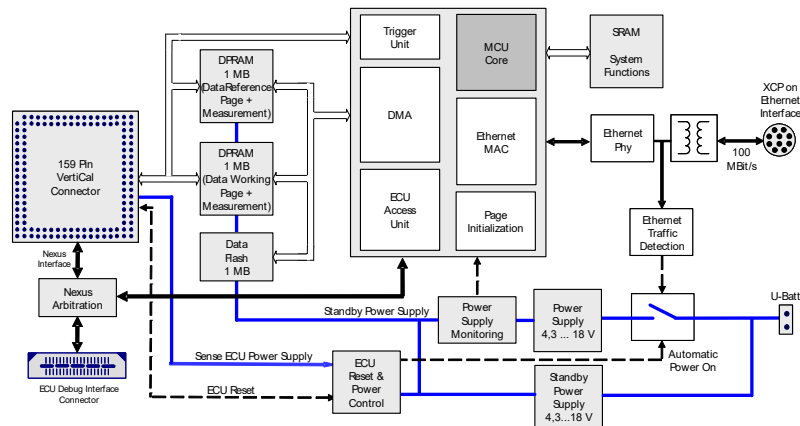

**Fig. 4-5** XETK-V1.0

Through the lower side of the base printed circuit board the microcontroller can communicate with other external memories or peripheral components of the development ECU.

While the microcontroller accesses the program data (not the program code) out of the data emulation memory, the content of the data emulation memory can simultaneously be modified by the calibration and development system through the Ethernet interface. This process enables adjustments of parameters, characteristic lines and maps through the calibration and development system. Using an additional measurement data memory area, the ECU microcontroller can send data to the calibration and development system which receives, buffers and processes this measured data.

A flash memory is available for permanent storage of the adjusted parameters (program data).

The 100 Mbit/s XETK Ethernet interface provides communication with the PC.

The power supply for the XETK-V1.0 is provided by a switch mode power supply, to minimize power dissipation.

### 4.3 Microcontroller Interface

The whole microcontroller interface to the calibration and development system memory has a 16 bit wide data bus and uses only one chip select for read and write accesses.

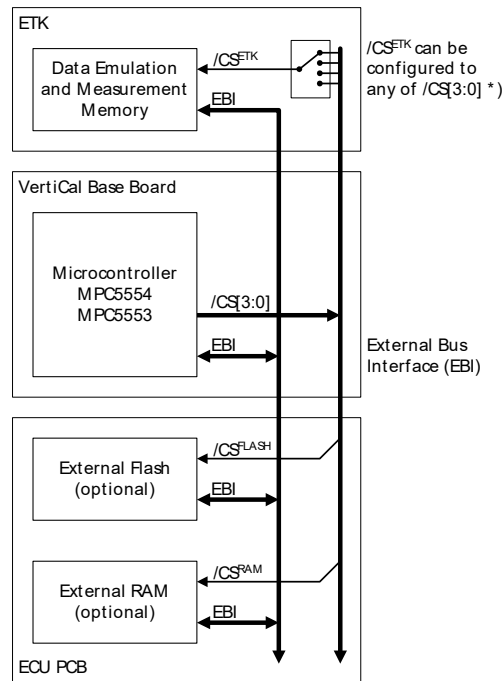

**Fig. 4-6** System with internal and external Memory (e.g. MPC5553, MPC5554)

The microcontroller can read and write its data directly from or to the data emulation and measurement data memory. Fig. 4-6 and Fig. 4-7 show an overview of a system with external Flash, RAM and additional data emulation and measurement memory (ETK memory). The microcontroller can read and write its data directly from or to the ETK memory. ETK memory chip select ( $/CS\_ETK$ ) can be configured to any of  $/CS[3:0]$ <sup>1</sup>.

**Note**

*This chip select must not be used by another external memory (e.g. Flash or RAM).*

<sup>1</sup>  $/CS1$  is not available for VertiCal base boards with MPC5553 microcontroller.

The MPC5534 microcontroller provides a separate second external bus interface which is exclusively routed to the VertiCal connector.

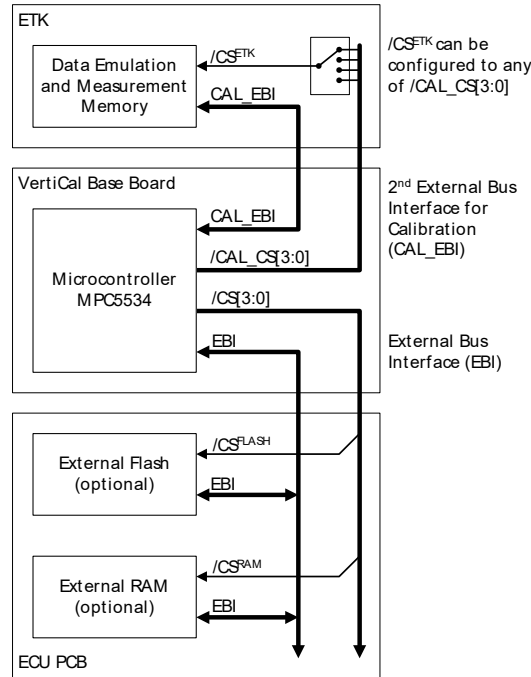

**Fig. 4-7** System with internal and external Memory (e.g. MPC5534)

#### 4.4 VertiCal Connector

The VertiCal connector interfaces the XETK-V1.0 with the ECU and provides access to the microcontrollers external bus and Nexus (JTAG) interface.

#### 4.5 Data Emulation and Data Measurement

The complete data emulation and measurement data memory consists of two 1 MByte pages (Fig. 4-8 "Data Emulation and Measurement Data Memory: 2 Pages with 1 MByte each"). The address range of the data emulation and measurement memory must be 1 MByte and it must be defined at a 1 MByte boundary.

Data emulation memory and measurement data memory must be located inside this 1 MByte address range. The segmentation of this address range between both memory parts is variable.

The measurement data memory and data emulation memory can have variable size and offset addresses inside this fixed address range.

#### 4.5.1 Data Emulation Memory

During operation of the ECU, only program data, not program code, can be modified by using the data emulation memory. Modification of program code could lead to a system crash. The program code is continuously processed out of the internal or external memory.

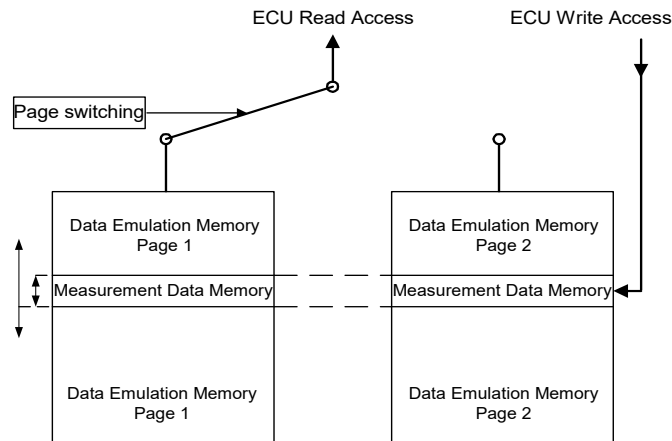

**Fig. 4-8** Data Emulation and Measurement Data Memory: 2 Pages with 1 MByte each

Reference data can be stored on one page ("Reference page") while the data on the other page ("Working page") can be modified. It is possible to switch between the two pages during operation through the application software.

#### 4.5.2 Measurement Data Memory

The measurement data memory must be located within the address space of the data emulation and measurement data memory. It can have variable size.

The measured data acquired from the PC via the XETK-V1.0 Ethernet interface can be stored here.

##### **Note**

*Because there is no write protection of the data emulation memory possible, it must be taken care not to override emulation data.*

#### 4.5.3 Triggering of Measurement Data Acquisition

The exact procedure for capturing measured data is explained in the documentation Display Table 13; only the hardware-specific features are mentioned here. The ECU microcontroller initiates a data acquisition task by writing an arbitrary

value to the trigger address at the so called trigger segment. The software of the ECU is able to start different data acquisition tasks by writing different trigger addresses (trigger 1 to trigger 48).

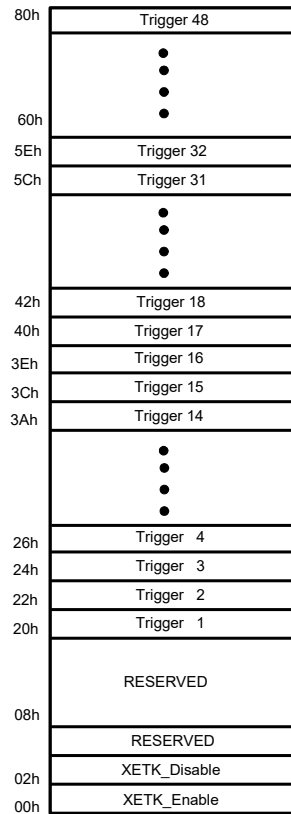

**Fig. 4-9** Division of the 128 Byte Trigger Segment

The XETK-V1.0 contains a trigger comparator which can be configured to select a segment of 128 Byte out of the measurement data memory address space (at a 128 Byte limit). This limit is known as the trigger segment address. Fig. 4-9 "Division of the 128 Byte Trigger Segment" shows the configuration of the 128 Byte trigger segment.

The XETK-V1.0 provides an extended trigger segment with up to 48 direct 16-bit hardware triggers.

**Note**

*The unused address areas within the trigger segment are reserved for future applications and must not be used for other purposes.*

For ECU setup and debugging purposes, the XETK-V1.0 can be disabled by writing an arbitrary value to the appropriate address (XETK\_Disable) in the trigger segment. When disabled, write accesses to the ETK data emulation and

measurement memory are not performed (with exception to the trigger segment). The XETK-V1.0 data lines are in tristate mode, even during read accesses. Writing to XETK\_Enable enables the ETK.

**Note**

*The time between two directly consecutive write accesses to the trigger segment must be greater than 100 ns.*

The disable/enable state is volatile, i.e. after power up, the ETK boots up in the state defined by the "ETK Configuration Tool" (ETK state after power up).

#### 4.5.4 Data Retention in Data Emulation Memory

---

The data emulation and measurement data memory physically consists of a static Dual Port RAM and is permanently supplied with power from the car battery, to guarantee that data is preserved even when the ignition is switched off. If the ECU with ETK is isolated from the battery, all data will be lost.

#### 4.6 Data Flash Memory

---

Flash memory is provided on the XETK-V1.0 for permanent storage of emulation data. Users can copy the contents of the data emulation and measurement data memory into the flash memory using the operating software. It is recommended that an updated data set is always stored in the flash memory.

The XETK-V1.0 has a circuit which recognizes and stores power failures. If this circuit detects power failures, and therefore a possible inconsistency of the emulation data, the ETK microcontroller initiates a copying procedure from Flash memory to DPR upon restart. The Flash memory data is copied to both emulation pages. A green LED on the ETK displays the status. The operating software announces the procedure by a message in the status line.

#### 4.7 Code Flash Memory

---

The program code is not emulated by the XETK-V1.0. The program code is stored in the ECU Flash memory ("on chip" and/or external) and is not modified by the XETK-V1.0. Only the accessible emulation data areas are emulated by the XETK-V1.0. The ECU Flash memory can be programmed with the normal Flash memory programming tools.



## 4.8 Power Supply

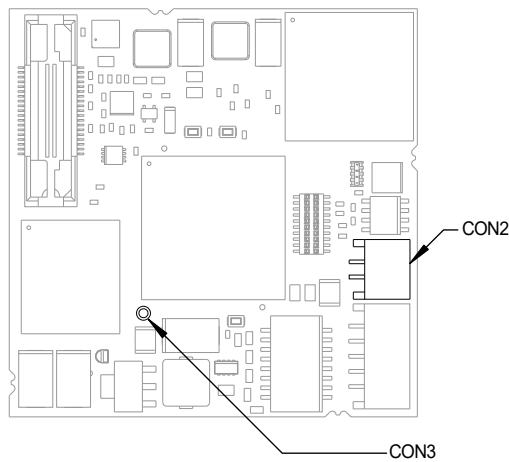

**Fig. 4-10** Power Supply Connectors CON2 and CON3

The XETK-V1.0 needs a permanent power supply. It is powered directly from the car battery. The input voltage may vary between 4.3 V and 18 V.

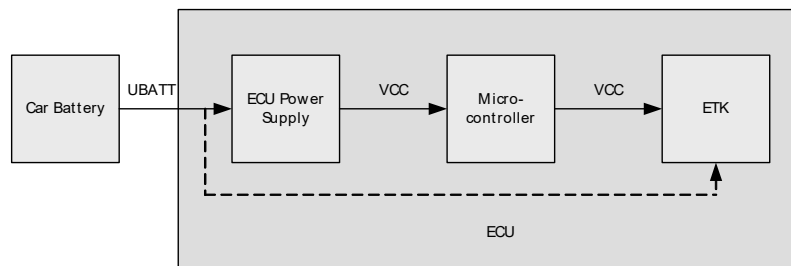

**Fig. 4-11** Power Supply monitoring

The ECU voltage VCC (VDDE2/3) is monitored by the ETK to recognize whether the ECU is switched on or off. In case of higher input voltages to the ETK an additional voltage converter is required. All necessary voltages are created through switching power supplies which minimizes heat build-up. The power supply of the ECU is not affected by the XETK-V1.0. An automatic switch ensures that the power supply of the XETK-V1.0 is automatically switched on and off.

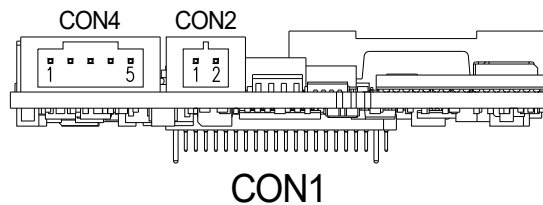

**Fig. 4-12** Power Supply Connector CON2

The XETK-V1.0 can be supplied with power through the 2-pin power supply connector CON2.

Additionally the through-hole solder pad CON3 can be used to connect a power supply  $U_{\text{Batt2}}$ . The power supply on CON3 must use the GND of CON2 (refer to chapter ).

<b>Pin CON2</b>	<b>Signal</b>	<b>Description</b>
1	$U_{\text{Batt}}$	Battery Supply Voltage for ETK
2	GND	Ground

## 4.9 XETK Ethernet Interface

The XETK Ethernet interface can directly connected to the PC. No additional ETAS module is required for the access to the ECU.

The interface is a standard full duplex 100Base-TX Ethernet interface. The XETK Ethernet interface is integrated in the ETAS IP world with automatic IP management and supports the open automotive "Universal Measurement and Calibration" standard "XCP on Ethernet" (TCP/IP, UDP/IP). The open XCP on Ethernet interface allows to connect the ES582.1 in third party application software.

### **Note**

*The XETK Ethernet interface is not compatible with the standard ETK interfaces in modules like e.g. ES910.2, ES590, ES1232-A.  
The XETK Ethernet interface is compatible with the ES600 module.*

The maximum length of the interface cable is specified for 30 m.

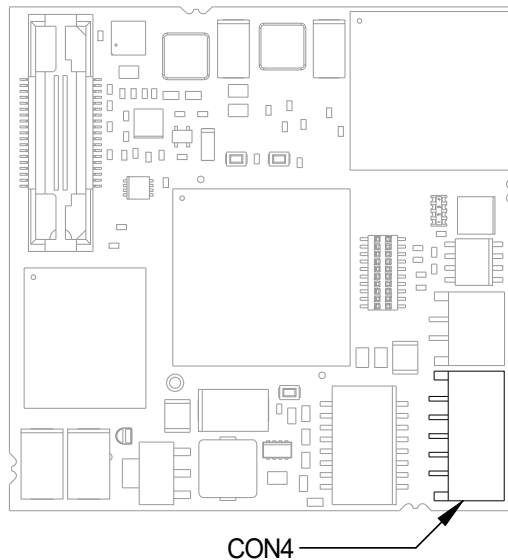

**Fig. 4-13** Location of the Ethernet Interface

### 4.10 Nexus (JTAG) Interface

The XETK-V1.0 features a Nexus (JTAG) debugging interface connector (Mictor 38 pin) as specified in the "The Nexus 5001 Forum - Standard for a Global Embedded Processor Debug Interface, Version 2.0".

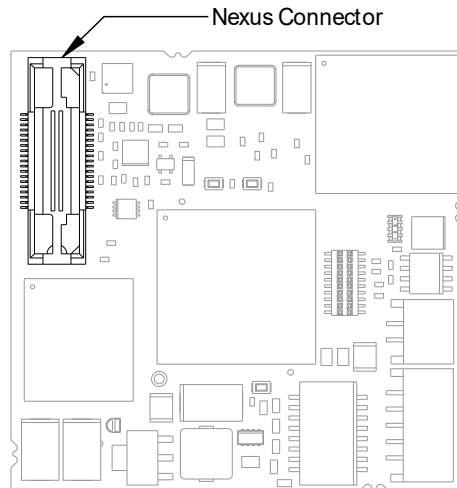

**Fig. 4-14** Location of the Nexus (JTAG) Interface

This connector can be used to attach debug and trace tools (e.g. Lauterbach debugger for MPC55xx - LA7610) if they support ETK arbitration. All JTAG and Mictor interface signals are directly connected to the corresponding signals on the VertiCal socket.

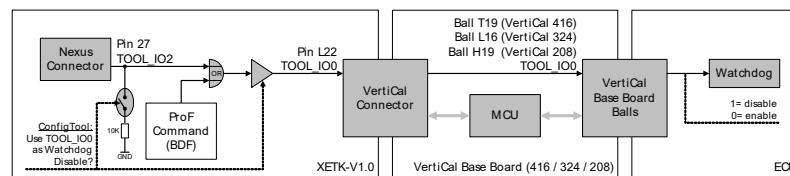

**Fig. 4-15** Nexus (JTAG) TOOL\_IO0 Signal Flow

The tool vendor specific signal TOOL\_IO0 (TDET/WDT) can be used to control and disable an external watchdog circuit on the ECU.

When the configuration parameter "Use TOOL\_IO0 as Watchdog Disable?" is set to "Yes" in the ETK Config Tool, the signal is driven from the Nexus (JTAG) connector to the signal TOOL\_IO0 (Pin L22) of the VertiCal connector.

This signal is routed directly to a ball of the VertiCal base board, completely bypassing the microcontroller on the VertiCal base board.

**Note**

*A base board with optional balls (see chapter 9.2) must be assembled when this feature is required.*

### 4.11 Status LEDs

There are three LEDs displaying the operating status of the XETK-V1.0 (Fig. 4-16 on page 29).

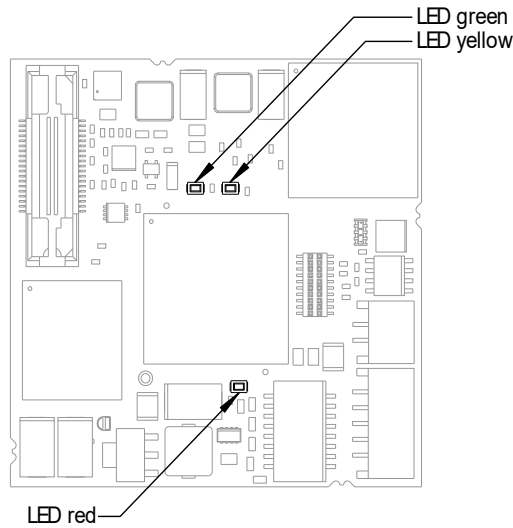

**Fig. 4-16** Status LEDs

LED	State	Meaning
Red	On	XETK-V1.0 is supplied with power and active (i.e. the ECU is switched on or the ETAS calibration and development system is connected and ready to communicate with the XETK-V1.0)
Green	On	When the power supply voltage drops below 3.5 V, the data retention of the DPRs is not longer ensured. As soon as the ETK is switched on again, the content of the ETK-Flash will be copied into reference and working page RAM. The green LED stays lit until the calibration and development system copies new data into RAM.
	Flashing	XETK-V1.0 is in RAM adapter mode. Measurement and calibration are not possible ( in all "XETK Application mode" except "XETK mode initialized").
	Off	Working page may be different to reference page. Working page and reference page may be different to the ETK-Flash.
Yellow	On	100 Mbit/s link to calibration system established
	Flashing	Communication active

## 4.12 Braindead Flashing

Braindead Flashing (BDF) means downloading program code to the non-volatile memory of the ECU (i.e. internal or external flash), regardless of the current memory contents. It is not required that a programming routine is present in the ECU - the memory may be empty or corrupted.

The XETK-V1.0 supports Braindead Flashing via Nexus (JTAG) debug interface for all MPC5500 family microcontrollers. It is recommended as standard method for all new projects.

### 4.12.1 Braindead Flashing via Nexus (JTAG) Debug Interface

This method uses the Nexus (JTAG) interface of the MCU's microcontroller to enable the debug mode of microcontroller and to download a flash programming driver into the microcontroller's internal SRAM.

After download, the microcontroller is given a resume/go command. It executes the programming driver which receives data via the ETK mailbox and programs it into the microcontroller's flash. When flash programming is done, a reset is issued and the microcontroller executes the recently programmed code.

The following steps are sequenced by a ProF control flow:

- Put ECU's microcontroller into reset
- Disable external watchdog timer (optional, see chapter 4.12.2 on page 31)
- Initiate microcontroller's debug mode and halt state
- Initialize the Internal SRAM
- Initialize the MMU registers to a known state
- Download flash programming driver into the internal RAM region of the controller that contains communication and flash routines
- Set Program Counter to point to the beginning of the boot code
- Resume microcontroller code execution by issuing a go/resume command
- Program the new ECU software to the non-volatile memory (internal or external flash)
- Reset the CPU (release Nexus (JTAG) debug interface control)



#### **CAUTION!**

*During Braindead Flashing via Nexus (JTAG), external debugger should be removed.*

#### **Note**

*When flashing an MPC5534 microcontroller, please ensure that your flash programming driver sets the Nexus (JTAG) access priority to internal SRAM higher than the priority for opcode fetches from internal SRAM (MPC5534 Crossbar register **XBAR\_MPR3**). ETAS suggests to set **XBAR\_MPC3** to the value **0x00000213**. When using the default priority for Nexus (JTAG) accesses, the ProF flow may fail as the ETK does not always gets access to the microcontrollers SRAM. See the MPC5534 reference manual section XBAR for details.*

**Note**

*The first command of the downloaded flash driver must be a "NOP" command, otherwise the driver will **not** work!*

#### 4.12.2 External Watchdog disable

---

The XETK-V1.0 provides a method to disable an external watchdog circuit on the ECU during braindead flashing.

The watchdog disable control signal is available on the VertiCal connector on signal TOOL\_IO0 (Pin L22). This signal is routed directly to a ball of the VertiCal base board, completely bypassing the microcontroller on the VertiCal base board.

When the XETK-V1.0 is configured to use this signal (Configuration parameter "Use VertiCal TOOL\_IO0 as Watchdog" set to "Yes"), the signal TOOL\_IO0 is set to logic high during brain dead flashing with the appropriate ProF command.

When "Use VertiCal TOOL\_IO0 as Watchdog" is set to "No", the TOOL\_IO0 pin is not driven by the XETK-V1.0 (high-Z).

See chapter "Nexus (JTAG) Interface" on page 28 for details about the disable watchdog logic circuit.

#### 4.13 Reset

---

The requirement for ETK reset mechanism is to ensure that power-up and power-down behavior of ECU is clean and smooth and to prevent corruption of data stored in the ETK.

To accomplish this the XETK-V1.0 senses the VDDE2/3 of the ECU. This allows it to detect when the ECU is off and forward this information to INCA. In addition, it allows the ETK to enter the power save mode if the PC is off or unplugged.

Furthermore, the XETK-V1.0 senses the status of the /RESET and /RSTOUT lines to generate a write protect signal for its memory.

Finally, the XETK-V1.0 generates a reset signal by pulling /RESET to keep the ECU in reset while the ETK is in power save mode and to prevent the  $\mu$ C from starting until the ETK is ready to work.

The ETK is ready to work when it has finished its initialization after leaving power save mode or after initial power-up. This feature allows it also to reset the ECU under tool control (required for INCA and ProF) and to perform an emergency stop of the ECU in case of ETK failure.

The ETK is ready to work when it has finished its initialization after leaving power save mode or after initial power-up. This feature allows it also to reset the ECU under tool control (required for INCA and ProF) and to perform an emergency stop of the ECU in case of ETK failure.

## 5 Installation

In this chapter, the hardware installation of the XETK-V1.0 is described.



### CAUTION!

#### **The XETK can be damaged or destroyed!**

*Some components of the interface board may be damaged or destroyed by electrostatic discharges. Please keep the board in its storage package until it is installed.*

*The board should only be taken from its package, configured, and installed at a work place that is protected against static discharge.*

### 5.1 Connection to the ECU



### CAUTION!

#### **Risk of short circuiting the internal signals of the ETK!**

*When you mount the ETK to the ECU, you must ensure that the screws and washers used will not penetrate the ETK printed circuit board.*

For mounting the XETK-V1.0 on the ECU accessories are required:

- a VertiCal base board and
- an Advanced Interconnect socket, mounted on the ECU printed circuit board (only when using a VertiCal base board with pin array).

It need to be ordered separately (refer chapter "Ordering Information" on page 63).

#### 5.1.1 VertiCal Base Board soldered on ECU PCB

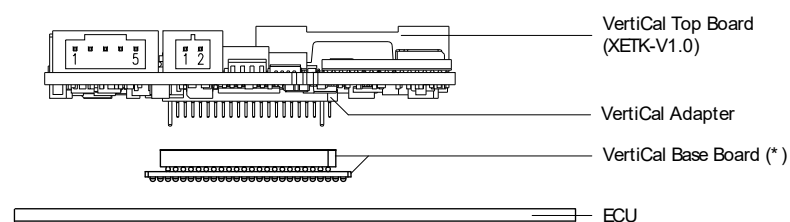

(\* ) Not delivered with XETK-V1.0

**Fig. 5-1** XETK-V1.0 soldered Connection to the ECU

The VertiCal base board fitted with solder ball footprints is used for direct and permanent connection to the development ECU (see Fig. 5-1).

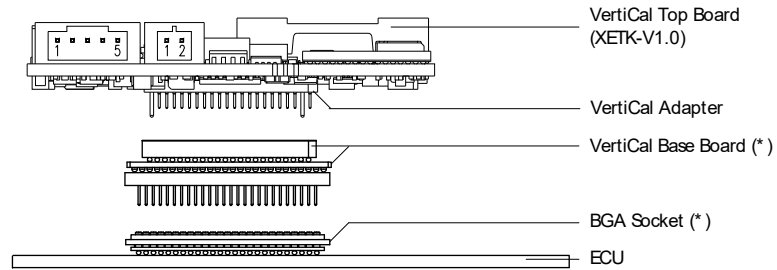

5.1.2 VertiCal Base Board mounted on ECU PCB

(\*) Not delivered with XETK-V1.0

**Fig. 5-2** XETK-V1.0 Connection to the ECU with Socket/Adapter

The VertiCal base board fitted with a "BGA adapter" connector allows connection and removal from an ECU development PCB which has been fitted with a compatible "BGA receiver" socket (see Fig. 5-2).

5.2 Wiring

5.2.1 XETK Ethernet Interface

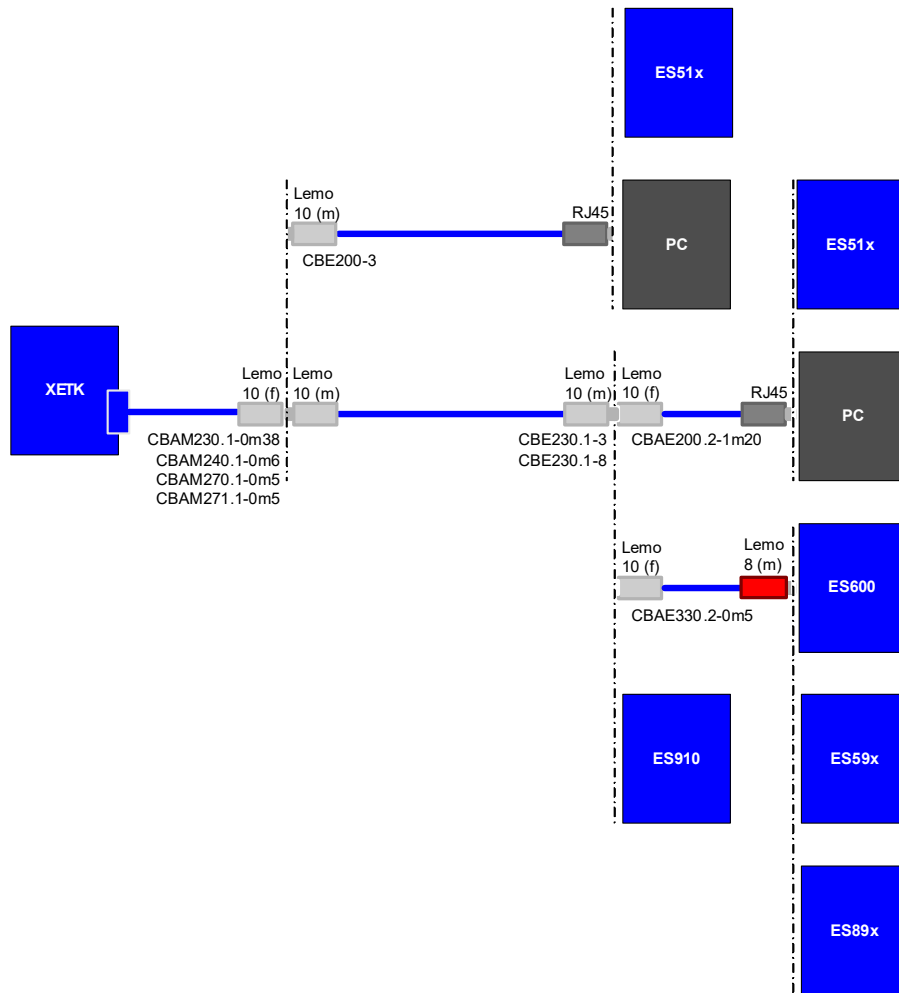

**Fig. 5-3** Wiring - XETK Ethernet Interface

The XETK Ethernet interface can directly connected to the PC. No additional ETAS module is required for the access to the ECU.

**Note**

The XETK Ethernet interface is not compatible with the ETK interfaces in modules like e.g. ES910.2, ES590, ES1232-A.

The XETK Ethernet interface is compatible with the ECU interface of the ES910 module and the Ethernet interfaces of the ES600 module.

5.2.2 Power Supply

The XETK-V1.0 needs a permanent power supply (refer chapter "Power Supply" on page 25). There are different versions to ensure it.

*Permanent Power Supply inside ECU available*

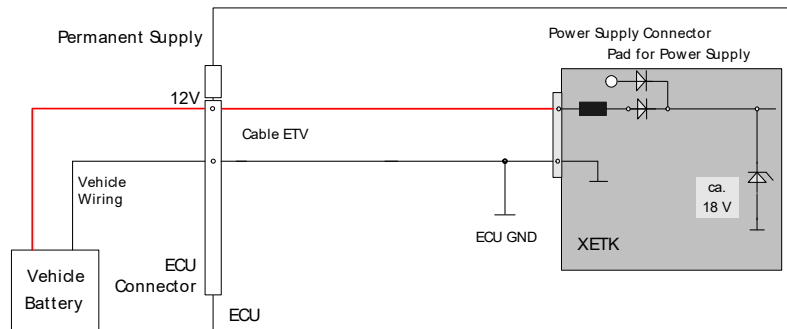

**Fig. 5-4** Wiring - Permanent Power Supply inside ECU available

*Permanent Power Supply inside ECU not available*

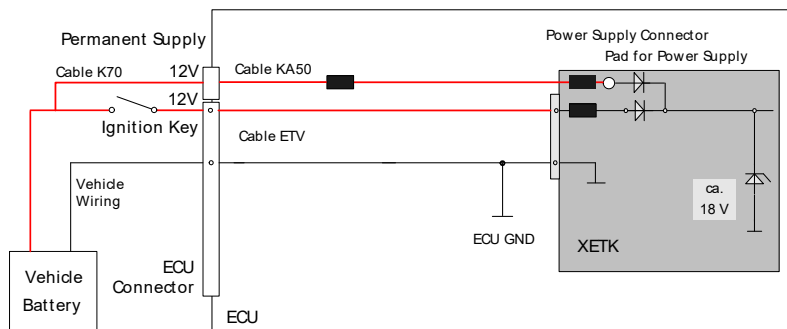

**Fig. 5-5** Wiring - Permanent Power Supply inside ECU not available

*Isolated Power Supply inside ECU*

The XETK-V1.0 does not require a galvanically isolated power supply. For special applications ETAS offers the isolated power supply ETP2.

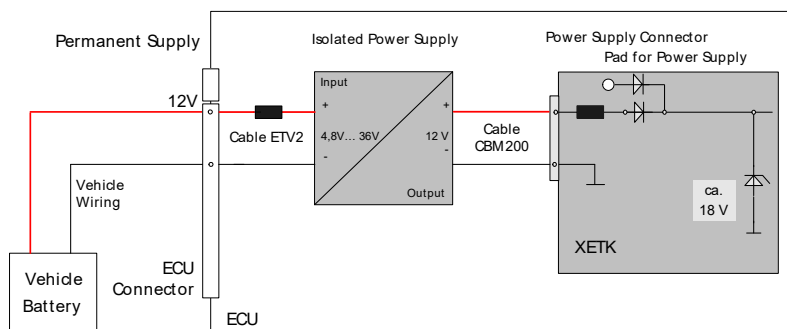

**Fig. 5-6** Wiring - Isolated Power Supply inside ECU

## 6 XETK Configuration

---

The "XETK Configuration" chapter includes a description of important XETK-V1.0 configuration parameters.

### 6.1 Overview

---

As already mentioned in previous chapters, some project-specific adjustments are necessary. Configuration data is stored permanently in a serial Flash. Generating a valid configuration data set is supported by the "XETK Configuration Tool". The "XETK Configuration Tool" contains information on all available XETKs. The user is supported through a graphical interface.

### 6.2 Configuration Parameter

---

The configuration of the XETK-V1.0 is possible with the "XETK Configuration Tool". Not all combinations of parameters make sense. The "XETK Configuration Tool" provides support concerning the configuration parameters. The following is a list with configuration parameters:

- **XETK Application mode** (XETK mode initialized, XETK mode not initialized, RAM adaptor not initialized, RAM adaptor initialized)

In all "XETK Application mode" modes except "XETK mode initialized" the XETK-V1.0 is not in its normal operation mode, i.e. measurement and calibration are not possible.

#### Note

*Do not use the XETK-V1.0 together with INCA with any another state than "XETK mode initialized". Always reconfigure the XETK after it was used as RAM adaptor to avoid unexpected behaviour of INCA.*

This feature allows it to use the XETK-V1.0 as a RAM extension. The possible states are:

- XETK mode initialized:  
The XETK is used in the normal way. When using the XETK together with INCA this mode gets set when an ASAM-2MC configuration is written to the XETK.
- XETK mode not initialized:  
Normal XETK operation, but when a power fail occurs no data gets copied from the backup flash into the dual ported RAM pages.
- RAM adaptor not initialized:  
The XETK is used as RAM extension.
- RAM adaptor initialized:  
The XETK is used as RAM extension. If a power fail occurs the memory from the backup flash gets copied into the RAM.

The default value is "XETK mode initialized".

- **Power-On State** (Active/Inactive)
  - Active:  
The XETK is enabled at ECU power on.

- Inactive:
  - The XETK is inactive when the ECU power on.
  - The default value is "Active".
- **Chip Select for XETK** (/CS0, /CS1, /CS2, /CS3)
  - Selects the XETK chip selects.
  - The default value is "/CS2".
- **ECU Watchdog Control** (Controlled by ECU, Enabled, Disabled)
  - Selects how the XETK controls the ECU watchdog (TOOL\_IO0, Pin L22 on the Vertical connector).
  - Controlled by ECU:
    - The XETK will not drive the signal (high-Z).
  - Enabled:
    - The XETK will drive the signal high, to enable the watchdog.
  - Disabled:
    - The XETK will drive the signal low, to disable the watchdog.
  - The default value is "Controlled by ECU".
- **ECU Boot Configuration** (Internal, Serial, External Single Master, External Multi Master, Selected by ECU)
  - Selects from which memory the ECU boots.
  - The default value is "Selected by ECU".
- **ECU JTAG / Nexus Interface voltage** (1.8V, 2.5 V, 3.3 V, Auto Detect)
  - Selects the Nexus / JTAG bus voltage, or lets the XETK detect the voltage.
  - The default value is "Auto Detect".
- **ECU bus Interface voltage** (2.5 V, 3.3 V, Auto Detect)
  - Selects the ECU bus voltage, or lets the XETK detect the voltage.
  - The default value is "Auto Detect".
- **XETK Initial Page** (Last Active Page, Working Page, Reference Page)
  - Selects the Data Page, that will be activated when the XETK wakes up from sleep mode.
  - Last Active Page:
    - The page active before entering sleep mode will be activated again.
  - Working Page:
    - The Working Page will be activated.
  - Reference Page:
    - The Reference Page will be activated.
  - The default value is "Last Active Page".
- **Initialization Pattern Address** (Field [4 byte])
  - Defines the address the XETK will write a 4 byte Initialization Pattern to when the ECU comes out of reset. The address must be a physical address within the Emulation RAM of the XETK.

- 0xFFFFFFFF:  
Feature is not enabled. The XETK will not write the Initialization Pattern. This is the recommended setting when using the XETK with INCA.
- n (0x00000000 to 0xFFFFFFFF)  
Feature is enabled. The XETK will write the Initialization Pattern to the specified address.

The default value is "0xFFFFFFFF".

- **Initialization Pattern** (Field [4 byte])

Defines the 4 byte pattern the XETK will write to the Initialization Address, if enabled, when the ECU comes out of reset.

- n (0x00000000 to 0xFFFFFFFF)

The default value is "0xFFFFFFFF".

## 7 Technical Data

---

The “Technical Data” chapter contains a summary of all technical data, pin assignments and hints to system requirements for operating the XETK-V1.0.

### Note

*The XETK-V1.0 can be shipped in the two different mechanical versions XETK-V1.0A and XETK-V1.0B (refer to chapter 7.11.1 on page 49 and chapter 7.11.2 on page 50).*

### 7.1 System Requirements

---

#### 7.1.1 ETAS Hardware

---

Compact Hardware: ES510, ES600 (INCA)  
ES910 (INCA, INTECRIO)

#### 7.1.2 Ethernet Interface of the PC

---

A PC with a free Ethernet interface (1 GBit/s or 100 Mbit/s, Full Duplex) with an RJ-45 connection is required. Ethernet interfaces realized by an additional PCMCIA network card in the PC must have a 32-bit data bus (card bus).

### Note

*It is imperative you disable the function which automatically switches to power-saving mode on your PC network card when there is no data traffic on the Ethernet interface!*

The manufacturers of the network cards have different names for this function. Example: “Link down Power saving

#### 7.1.3 Software Support

---

You need following software versions to support the XETK-V1.0:

Software	Version (or higher)
HSP (Firmware)	6.0.1
INCA	6.0.0 HF1

### 7.2 Supported Microcontroller

---

Item	Characteristics
Supported microcontrollers	VertiCal base board with Freescale MPC5534, MPC5553, MPC5554, MPC5565, MPC5566, MPC5567, MPC5674F

### 7.3 Environmental Conditions

Item	Characteristics
Temperature range	- 40 °C to +110 °C - 40 °F to +230 °F

### 7.4 Power Supply

Parameter	Symbol	Condition	Min	Typ	Max	Unit
Permanent power supply (car battery)	$U_{\text{Batt}}$	Vehicle usage <sup>1)</sup>	4.3	12	18	V
[all values $\pm 0\%$ ]						
Standby current	$I_{\text{STBY}}$	$U_{\text{Batt}} = 12 \text{ V}$ ; ECU off; no load from ECU; $T = 20 \text{ }^\circ\text{C}$	1	18	25	mA
Operating current	$I_{\text{Batt}}$	$U_{\text{Batt}} = 12 \text{ V}$ ; ECU on; no load from ECU; $T = 20 \text{ }^\circ\text{C}$	60	120	180	mA
Power dissipation	$P_{\text{Batt}}$	$U_{\text{Batt}} = 12 \text{ V}$ ; no load from ECU; $T = 20 \text{ }^\circ\text{C}$ ; $I = 0 \text{ mA}$ at pin VDDSRAM_OUT		1.44		W

1) The XETK-V1.0 implements reverse voltage protection in the same range and may be used only with central load dump protection.

### 7.5 Configuration

Item	Characteristics
Configuration	Project-specific configuration for - memory configurations stored in EEPROM
Update	Logic devices updated through software



## 7.6 XETK Ethernet Interface

---

<b>Item</b>	<b>Characteristics</b>
Connection	100 Mbit/s Ethernet, Full Duplex
	PC Card 32 bit
Protocol	XCP on TCP/IP or UDP/IP
IP address	Dynamic (standard, for INCA) or static (e.g. for Rapid Prototyping) by using the XETK Configuration Tool (default IP address: 192.168.40.16)
Cable length	max. 30 m / 100 ft
Ethernet interface	DC decoupling

**Note**

*To ensure successful initialization of the network card of your PC, refer to chapter 7.1.2 on page 39.*

## 7.7 Microcontroller Bus Interface

Parameter	Symbol	Condition	Min	Typ	Max	Unit
ECU Bus Supply Voltage - Level Detect	$U_{VDDE2/3}$	ECU on	1.88	1.98	2.08	V
		ECU off	1.77	1.87	1.97	V
ECU Bus Supply Voltage - Level Detect	$U_{VDDE2/3}$	Level Detect: 2.5 V			2.9	V
		Level Detect: 3.3 V	3.1			V
ECU Bus Supply Voltage - Level Detect	$I_{VDDE2/3}$	$U_{VDDE2/3} = 3.3 \text{ V}$			0.1	mA
Nexus Level Voltage - Level Detect	$U_{VDDE7}$	Level Detect: 1.8 V			1.9	V
		Level Detect: 2.5 V	2.1		2.8	V
		Level Detect: 3.3 V	3.1			V
Nexus Level Voltage - Level Detect	$I_{VDDE2/3}$	Level Detect: 3.3 V			0.1	mA

## 7.8 Testcharacteristics

Parameter	Symbol	Condition	Min	Max	Unit
Reset delay 1	$t_{Reset1}$	$U_{Batt} = 12 \text{ V}$ $U_{VDDE2/3} = 0 \text{ V} \uparrow 3.3 \text{ V} / 2.5 \text{ V}$	25	40	ms
Reset delay 2	$t_{Reset2}$	$U_{Batt} = 0 \text{ V} \uparrow 12 \text{ V}$	250	460	ms

### Note

$t_{Reset1}$ : Delay of ECU reset through ETK without transferring the Flash ( $U_{Batt}$  present,  $U_{VDDE2/3}$  will be switched on)  
 $t_{Reset2}$ : max. delay of ECU reset through ETK ( $U_{Batt}$  and  $U_{VDDE2/3}$  will be switched on)

## 7.9 Electrical Characteristics

Signal	Condition	Pin Type	V <sub>OL</sub> (max) [V]	V <sub>OH</sub> (min) [V]	V <sub>OH</sub> (max) [V]	V <sub>IL</sub> (max) [V]	V <sub>IH</sub> (min) [V]	V <sub>IH</sub> (max) [V]	Leakage current [μA]	Additional Load by ETK (typ) [pF] <sup>1)</sup>
C_ADDR[30...12]	U <sub>VDD</sub> E2/3 = 2.5 V	I	-	-	-	0.69	1.61	4.6	-5/+5	10
	U <sub>VDD</sub> E2/3 = 3.3 V	I	-	-	-	0.9	2.1	4.6	-5/+5	10
C_DATA[15..0]	U <sub>VDD</sub> E2/3 = 2.5 V; I <sub>OH</sub> = -9 mA; I <sub>OL</sub> = 9 mA	I/O	0.55	1.75	2.5	0.7	1.6	4.6	-5/+5	10
	U <sub>VDD</sub> E2/3 = 3.3 V; I <sub>OH</sub> = -12 mA; I <sub>OL</sub> = 12 mA	I/O	0.7	2.3	3.3	0.8	2	4.6	-5/+5	10
RD_AWR; /OE; /WE[1..0]; /CS[3..0]		I	-	-	-	0.7	1.7	4.1	-55/-230	10
/RESETOUT		I	-	-	-	0.7	1.7	5.5	-25/+25	25
/RESET	I <sub>Dmax</sub> = 0.2A	I/OD	-	-	-	0.7	1.7	5.5	-25/+30	50
BOOTCFG[1..0]; /RSTCFG	V <sub>OH</sub> at -8 mA load	I/O	0.7	2.4	3.3	0.7	1.7	5.5	-25/+25	20

Signal	Condition	Pin Type	$V_{OL}$ (max) [V]	$V_{OH}$ (min) [V]	$V_{OH}$ (max) [V]	$V_{IL}$ (max) [V]	$V_{IH}$ (min) [V]	$V_{IH}$ (max) [V]	Leakage current [ $\mu$ A]	Additional Load by ETK (typ) [pF] <sup>(1)</sup>
TCK; TMS	$U_{VDDDE7} = 1.8$ V; $I_{OH} = -6$ mA; $I_{OL} = 6$ mA	O	0.3	1.25	1.8	-	-	4.6	-1630/ -1820	25
	$U_{VDDDE7} = 2.5$ V; $I_{OH} = -6$ mA; $I_{OL} = 12$ mA	O	0.4	2	2.5	-	-	4.6	-2280/ -2520	25
	$U_{VDDDE7} = 3.3$ V; $I_{OH} = -18$ mA; $I_{OL} = 18$ mA	O	0.4	2.4	3.3	-	-	4.6	-2980/ -3320	25
TDI	$U_{VDDDE7} = 1.8$ V; $I_{OH} = -6$ mA; $I_{OL} = 6$ mA	O	0.3	1.25	1.8	-	-	4.6	-25/ -25	25
	$U_{VDDDE7} = 2.5$ V; $I_{OH} = -6$ mA; $I_{OL} = 12$ mA	O	0.4	2	2.5	-	-	4.6	-25/ -25	25
	$U_{VDDDE7} = 3.3$ V; $I_{OH} = -18$ mA; $I_{OL} = 18$ mA	O	0.4	2.4	3.3	-	-	4.6	-25/ -25	25

Signal	Condition	Pin Type	$V_{OL}$ (max) [V]	$V_{OH}$ (min) [V]	$V_{OH}$ (max) [V]	$V_{IL}$ (max) [V]	$V_{IH}$ (min) [V]	$V_{IH}$ (max) [V]	Leakage current [ $\mu$ A]	Additional Load by ETK (typ) [pF] <sup>(1)</sup>
JCOMP	$U_{VDD7} = 1.8$ V; $I_{OH} = -6$ mA; $I_{OL} = 6$ mA	O	0.3	1.25	1.8	-	-	4.6	-1630/ -1820	25
	$U_{VDD7} = 2.5$ V; $I_{OH} = -6$ mA; $I_{OL} = 12$ mA	O	0.4	2	2.5	-	-	4.6	-2280/ -2520	25
	$U_{VDD7} = 3.3$ V; $I_{OH} = -18$ mA; $I_{OL} = 18$ mA	O	0.4	2.4	3.3	-	-	4.6	-2980/ -3320	25
TDO	$U_{VDD7} = 1.8$ V	I	-	-	-	0.6	1.2	4.6	-20/+20	25
	$U_{VDD7} = 2.5$ V	I	-	-	-	0.7	1.6	4.6	-20/+20	25
	$U_{VDD7} = 3.3$ V	I	-	-	-	0.8	2	4.6	-20/+20	25
/RDY; MDO0	$U_{VDD7} = 1.8$ V	I	-	-	-	0.6	1.2	4.6	-1/+1	10
	$U_{VDD7} = 2.5$ V	I	-	-	-	0.7	1.6	4.6	-1/+1	10
	$U_{VDD7} = 3.3$ V	I	-	-	-	0.8	2	4.6	-1/+1	10
TOOLIO[0]	$I_{OH} = -12$ mA; $I_{OL} = 12$ mA	O	0.45	2.4	3.3	0.7	1.7	4.1	-510/ +510	20
TOOLIO[3..1]		I	-	-	-	0.7	1.7	4.1	-510/ +510	20

Signal	Condition	Pin Type	V <sub>OL</sub> (max) [V]	V <sub>OH</sub> (min) [V]	V <sub>OH</sub> (max) [V]	V <sub>IL</sub> (max) [V]	V <sub>IH</sub> (min) [V]	V <sub>IH</sub> (max) [V]	Leakage current [μA]	Additional Load by ETK (typ) [pF] <sup>1)</sup>
MDO[11..1]; /EVTI; /EVTO; MCKO; /MSEO[1..0]		-		-	-	-	-	-	-	5
Clockout		-		-	-	-	-	-	-	3

<sup>1)</sup> Vertical plug and Mictor connector not considered; PCB 1 pF/cm

## 7.10 Switching Characteristics

The following diagrams show the timings the XETK-V1.0 can process.

### Note

All timings are measured at a reference level of 1.5 V. Output signals are measured with 10 pF to ground and 50 Ω to 1.5 V.

### 7.10.1 Read Timing: Data Emulation and Measurement Data DPR

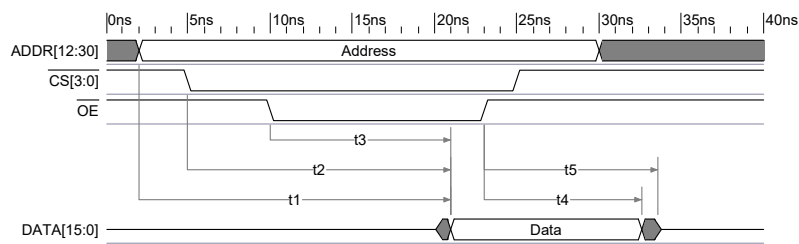

**Fig. 7-1** Read Cycle: Data Emulation and Measurement Data DPR

Para.	Description	Min	Max	Unit
t <sub>1</sub>	Address access time		20	ns
t <sub>2</sub>	Chip select access time		24	ns
t <sub>3</sub>	Output enable until valid data is driven to bus		24	ns
t <sub>4</sub>	Valid data is driven to bus after output enable inactive	1		ns
t <sub>5</sub>	Time after read until other device may drive bus		14	ns

### 7.10.2 Write Timing: Data Emulation and Measurement Data DPR

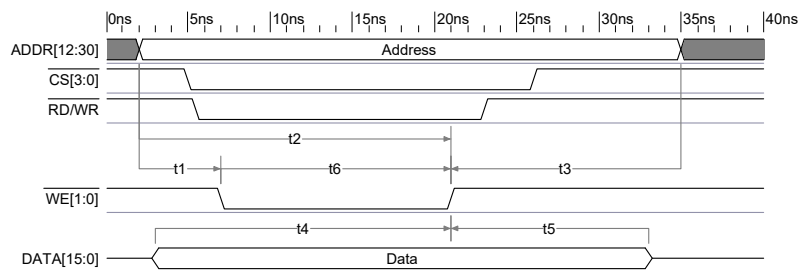

**Fig. 7-2** Write Cycle: Data Emulation and Measurement Data DPR

Para.	Description	Min	Max	Unit
t <sub>1</sub>	Address valid before write enable becomes active	4		ns
t <sub>2</sub>	Address valid before end of write	16		ns
t <sub>3</sub>	Address valid after end of write	8		ns

<b>Para.</b>	<b>Description</b>	<b>Min</b>	<b>Max</b>	<b>Unit</b>
t <sub>4</sub>	Data valid before end of write	14		ns
t <sub>5</sub>	Data valid after end of write	8		ns
t <sub>6</sub>	Write enable pulse width	13		ns



7.11 Mechanical Dimensions

The reference measure for all drawings is millimeter.

7.11.1 XETK-V1.0A

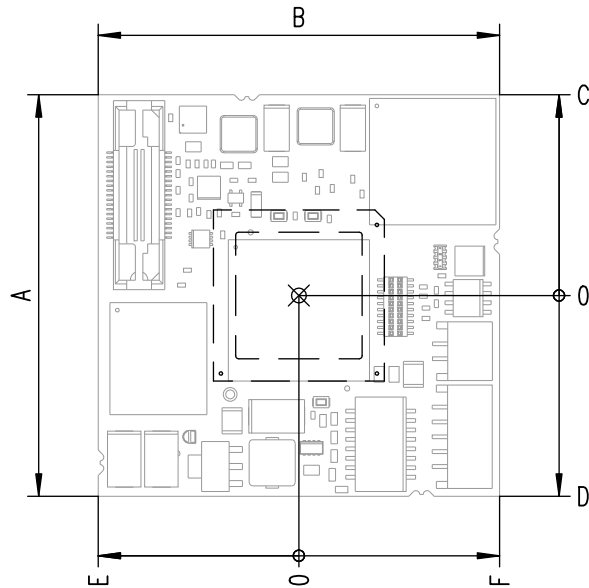

**Fig. 7-3** XETK-V1.0A Dimensions - Top View

Dimension	Millimeters	Inches
A	54.00	2.126
B	54.00	2.126
C	27.00	1.063
D	27.00	1.063
E	27.00	1.063
F	27.00	1.063

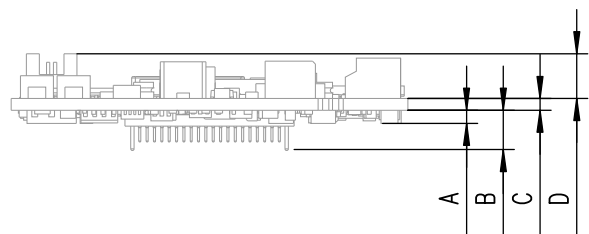

**Fig. 7-4** Mechanical Dimensions XETK-V1.0A: Microcontroller with Socket Adapter mounted

Dimension	Millimeters	Inches
A	2.00	0.079
B	5.36	0.211
C	1.70	0.067
D	6.10	0.240

7.11.2 XETK-V1.0B

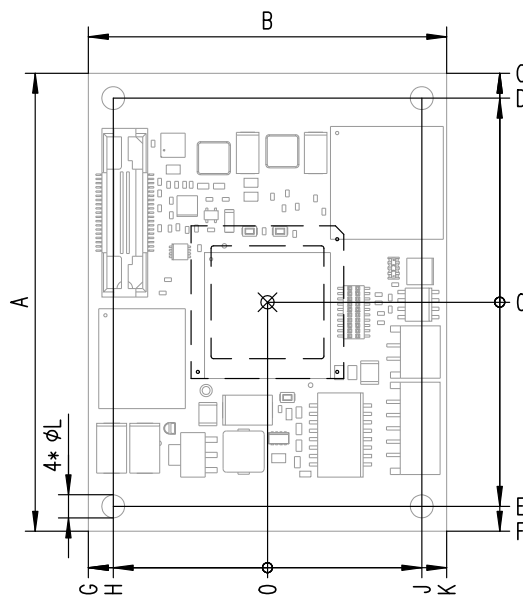

**Fig. 7-5** XETK-V1.0B Dimensions - Top View

A	69.00	2.717
B	54.00	2.126
C	34.50	1.358
D	30.75	1.211
E	30.75	1.211
F	34.50	1.358
G	27.00	1.063
H	23.25	0.915
J	23.25	0.915
K	27.00	1.063
L	3.50	0.138

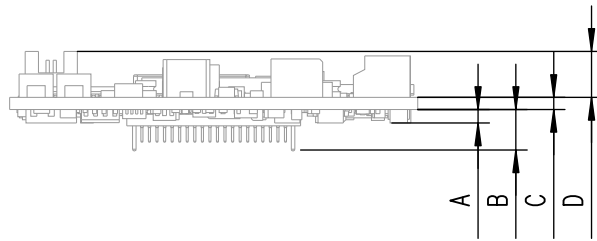

**Fig. 7-6** Mechanical Dimensions XETK-V1.0B: Microcontroller with Socket Adapter mounted

<b>Dimension</b>	<b>Millimeters</b>	<b>Inches</b>
A	2.00	0.079
B	5.36	0.211
C	1.70	0.067
D	6.10	0.240

## 7.12 Pin Assignment

### 7.12.1 VertiCal Connector

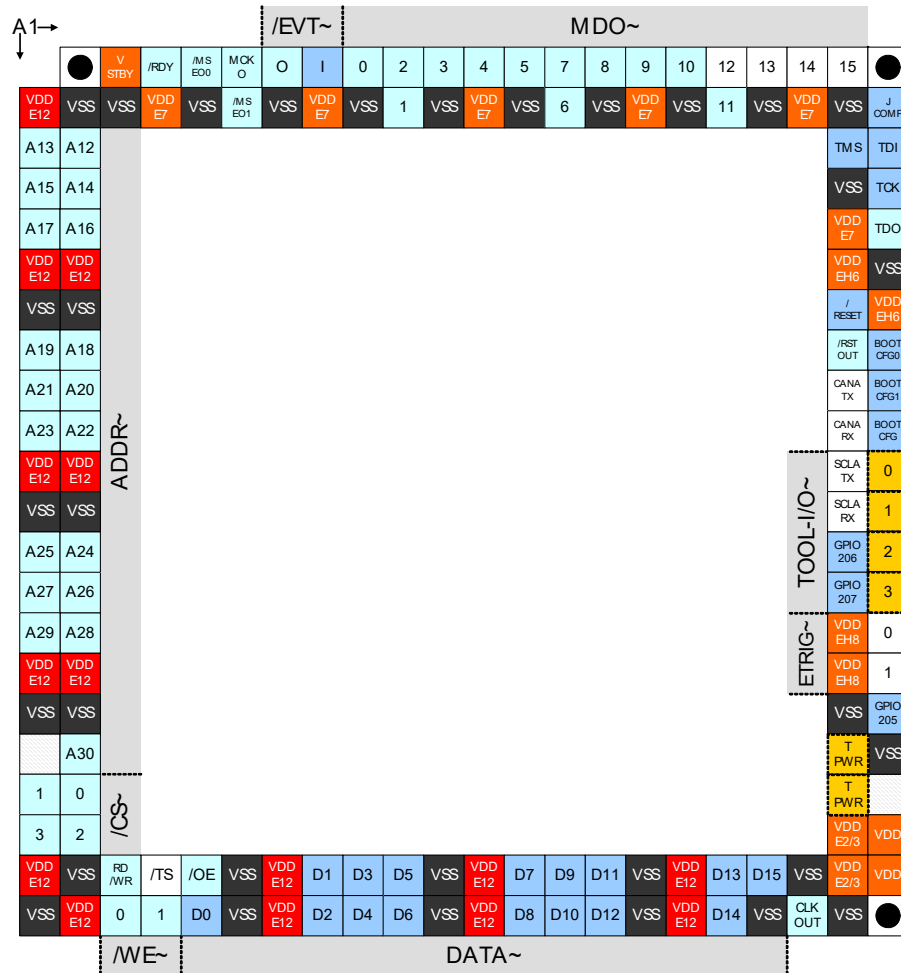

Fig. 7-7 VertiCal Connector

<b>Pin(s)</b>	<b>Name</b>	<b>Description</b>
C2	C_ADDR12	External Address Bus
C1	C_ADDR13	
D2	C_ADDR14	
D1	C_ADDR15	
E2	C_ADDR16	
E1	C_ADDR17	
H2	C_ADDR18	
H1	C_ADDR19	
J2	C_ADDR20	
J1	C_ADDR21	
K2	C_ADDR22	
K1	C_ADDR23	
N2	C_ADDR24	
N1	C_ADDR25	
P2	C_ADDR26	
P1	C_ADDR27	
R2	C_ADDR28	
R1	C_ADDR29	
V2	C_ADDR30	
W2	/C_CS0	Chip Select
W1	/C_CS1	Chip Select
Y2	/C_CS2	Chip Select
Y1	/C_CS3	Chip Select
AA3	C_RD/WR	Read/Write
AB3	/C_WE0	Write/Byte Enable
AB4	/C_WE1	Write/Byte Enable
AA5	/C_OE	Output Enable
AA4	/C_TS <sup>2)</sup>	Transfer Start

<b>Pin(s)</b>	<b>Name</b>	<b>Description</b>
AB5	C_DATA0	External Data Bus
AA8	C_DATA1	
AB8	C_DATA2	
AA9	C_DATA3	
AB9	C_DATA4	
AA10	C_DATA5	
AB10	C_DATA6	
AA13	C_DATA7	
AB13	C_DATA8	
AA14	C_DATA9	
AB14	C_DATA10	
AA15	C_DATA11	
AB15	C_DATA12	
AA18	C_DATA13	
AB18	C_DATA14	
AA19	C_DATA15	
A6	MCKO	Nexus Message Clock Out
A9	MDO0	Nexus Message Data Out
B10	MDO1	
A10	MDO2	
A11	MDO3	
A12	MDO4	
A13	MDO5	
B14	MDO6	
A14	MDO7	
A15	MDO8	
A16	MDO9	
A17	MDO10	
B18	MDO11	
A18	MDO12 <sup>1)</sup>	Nexus Message Data Out (reserved for future extension)
A19	MDO13 <sup>1)</sup>	
A20	MDO14 <sup>1)</sup>	
A21	MDO15 <sup>1)</sup>	
A5	/MSEO0	
B6	/MSEO1	
A8	/EVTI	Nexus Event Input
A7	/EVTO	Nexus Event Output
A4	/RDY	Nexus Ready Output

<b>Pin(s)</b>	<b>Name</b>	<b>Description</b>
D22	TCK	JTAG Test Clock Input
C21	TMS	JTAG Test Mode Select Input
C22	TDI	JTAG Test Data Input
E22	TDO	JTAG Test Data Output
B22	JCOMP (/TRST)	JTAG Compliance Input (JTAG Reset)
G21	/RESET	External Reset Input/Sense
H21	/RSTOUT	External Reset Output
K22	RSTCFG	Reset Configuration Input
H22	BOOTCFG0	Reset Configuration 0
J22	BOOTCFG1	Reset Configuration 1
U22	GPIO205 <sup>1)</sup>	General Purpose I/O
N21	GPIO206 <sup>1)</sup>	General Purpose I/O
P21	GPIO207 <sup>1)</sup>	General Purpose I/O
J21	CNTXA <sup>2)</sup>	CAN A Transmit
K21	CNRXA <sup>2)</sup>	CAN A Receive
L21	TXDA <sup>2)</sup>	SCI A Transmit
M21	RXDA <sup>2)</sup>	SCI A Receive
R22	ETRIG0 <sup>2)</sup>	External Trigger 0
T22	ETRIG1 <sup>2)</sup>	External Trigger 1
AB20	CLKOUT <sup>1)</sup>	System Clock Output
L22	WDT_DIS	External Watchdog Disable (not connected to MCU)
M22	TOOLIO_1 <sup>1)</sup>	VertiCal Tool I/O connection to ECU
N22	TOOLIO_2 <sup>1)</sup>	
P22	TOOLIO_3 <sup>1)</sup>	
B1, F1, F2, L1, L2, T1, T2, AA1, AA7, AA12, AA17, AB2, AB7, AB12, AB17	VDDE12	ECU Calibration Bus Supply Voltage (MPC5534)
A3	VSTBY	Microcontroller Internal RAM Supply Voltage
Y22, AA22	VDD <sup>2)</sup>	Microcontroller Internal Logic Supply Voltage
Y21, AA21	VDDE2/3	ECU Bus Supply Voltage
B4, B8, B12, B16, B20, E21	VDDE7	Microcontroller Supply Voltage (Nexus)
F21, G22	VDDEH6 <sup>2)</sup>	Microcontroller Supply Voltage (Reset)
R21, T21	VDDEH8 <sup>2)</sup>	Microcontroller Supply Voltage (GPIO205 & ETRIG[1:0])
V21, W21	TPWR <sup>2)</sup>	Unregulated Battery Voltage Input

<b>Pin(s)</b>	<b>Name</b>	<b>Description</b>
B2, B3, B5, B7, B9, B11, B13, B15, B17, B19, B21, D21, F22, G1, G2, M1, M2, U1, U2, U21, V22, AA2, AA6, AA1, AA16, AA20, AB1, AB6, AB11, AB16, AB19, AB21	VSS	Ground
V1, W22	Reserved <sup>2)</sup>	Reserved for future extensions
A2, A22, AB22	Locating Pins	No electrical function

<sup>1)</sup> = not used by XETK-V1.0

<sup>2)</sup> = not connected



## 7.12.2 Nexus (JTAG) Connector

Mictor #	XETK-V1.0 (DS)	Comment
1	Reserved	Reserved for future functionality
2	Reserved	Reserved for future functionality
3	Reserved	Reserved for future functionality
4	Reserved	Reserved for future functionality
5	MDO9	
6	CLKOUT	
7	/IRQ3/GPIO212	
8	MDO8	
9	/RESET	
10	/EVTI	
11	TDO	
12	VDDE7	Nexus I/O voltage (sense only)
13	MDO10	
14	/RDY	
15	TCK	
16	MDO7	
17	TMS	
18	MDO6	
19	TDI	
20	MDO5	
21	JCOMP	= /TRST
22	MDO4	
23	MDO11	
24	MDO3	
25	/RSTOUT	
26	MDO2	
27	TDET/WDT	Watchdog disable input and tool detect output
28	MDO1	
29	GPIO207	MCU GPIO
30	MDO0	
31	UBATT	Optional XETK-V1.0 supply voltage, standard supply path is flying lead
32	/EVTO	
33	UBATT	Optional XETK-V1.0 supply voltage, standard supply path is flying lead
34	MCKO	
35	GPIO206	MCU GPIO

Mictor #	XETK-V1.0 (DS)	Comment
36	/MSEO1	
37	VSTBY	Power Supply for MCU internal RAM
38	/MSEO0	

**Note**

*The specification of the Nexus (JTAG) interface bases on the "Nexus 5001 Forum™ Standard for a Global Embedded Processor Debug Interface". This standard was adapted by Freescale (Freescale Semiconductor Application Note AN 2614).*

## 8 Cables and Accessories

The “Cables and Accessories” chapter contains an overview of the available cables and accessories.

### 8.1 ECU Adapter Cable

**Note**

*The screws for mounting ECU adapter cables are not included in the cable delivery. They need to be ordered separately. For screw manufacturers and order numbers refer to the description of the cables.*

#### 8.1.1 CBAM230.1 Adapter Cable

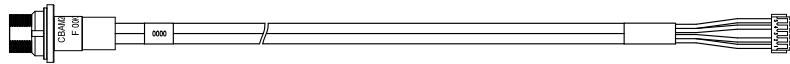

**Fig. 8-1** CBAM230.1 Adapter Cable

XETK ECU Adapter Cable, 100MBit/s, suitable for ECU flush mounting (M12), 0m38 length, shield connected to socket. Usable for ECUs with shielded housing.

Product	Length	Order-No
CBAM230.1-0m38	0.38 m	F 00K 105 791

#### 8.1.2 CBAM240.1 Adapter Cable



**Fig. 8-2** CBAM240.1 Adapter Cable

XETK ECU Adapter Cable, 100MBit/s, shield connected to ECU-housing (lead-through diameter for cable: 10mm), 0m6 length, shield bare for cable gland, isolated to the XETK. Usable for ECUs with shielded housing.

Product	Length	Order-No
CBAM240.1-0m6	0.6 m	F 00K 105 792

8.2 PC Interface Cable

8.2.1 CBE200-x Cable



**Fig. 8-3** CBE200-x Cable

Order Name	Short Name	Order Number
Ethernet PC Connection Cable 1GBit/s, Lemo 1B FGE - RJ45 (10mc-8mc), 3 m	CBE200-3	F 00K 104 373
Ethernet PC Connection Cable 1GBit/s, Lemo 1B FGE - RJ45 (10mc-8mc), 5 m	CBE200-5	F 00K 105 171
Ethernet PC Connection Cable 1GBit/s, Lemo 1B FGE - RJ45 (10mc-8mc), 8 m	CBE200-8	F 00K 104 374
Ethernet PC Connection Cable 1GBit/s, Lemo 1B FGE - RJ45 (10mc-8mc), 20 m	CBE200-20	F 00K 104 372

8.2.2 CBAE200.2 Adapter Cable

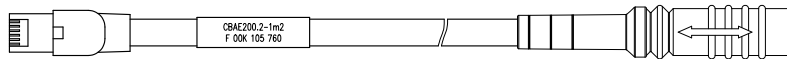

**Fig. 8-4** CBAE200.2 Adapter Cable

Cable adapter to connect CBE230 cable to the PC over an RJ45 connector. The CBAE200.2-1m20 supports Gigabit Ethernet.

Product	Length	Order-No
CBAE200.2-1m20	1.20 m	F 00K 105 760

### 8.3 ETAS Module Interface Adapter Cable

---

#### 8.3.1 CBE230.1 Cable

---

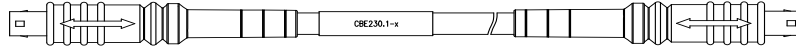

**Fig. 8-5** CBE230.1 Cable

Gigabit Ethernet connection cable for ETAS devices. IP67 rated Lemo connectors on both sides. Gigabit Ethernet cable with power supply.

Product	Length	Order-No
CBE230.1-3	3 m	F 00K 105 757
CBE230.1-8	8 m	F 00K 105 758

#### 8.3.2 CBAE330.2 Adapter Cable

---

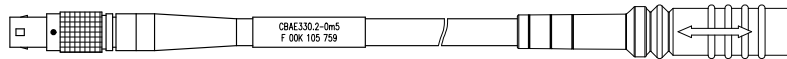

**Fig. 8-6** CBAE330.2 Adapter Cable

Gigabit to 100MBit/s Ethernet Adapter for connection of CBE230 to ES600.

Cable adapter to connect CBE230 cable with the ES600. Power supply over the CBAE330.2 cable adapter is not supported.

Product	Length	Order-No
CBAE330.2-0m5	0.5 m	F 00K 105 759

### 8.4 Power Supply Cables

---

#### 8.4.1 Cable ETV

---

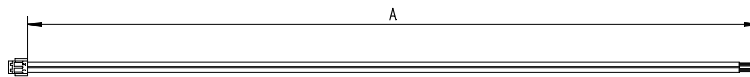

**Fig. 8-7** Power Supply Cable ETV

Dim	Millimeters	Inches
<b>A</b>	190.00	7.480

8.4.2 Cable K70

---

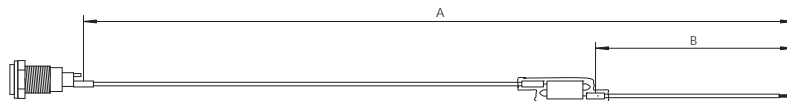

**Fig. 8-8** Power Supply Cable K70

Dim	Millimeters	Inches
<b>A</b>	2000	78.74

8.4.3 Cable KA50

---

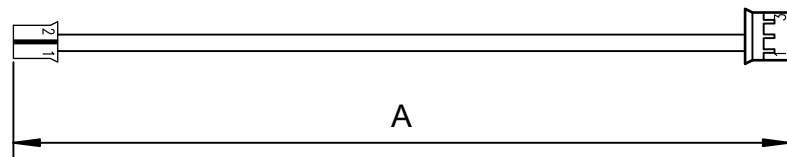

**Fig. 8-9** Power Supply Cable KA50

Dim	Millimeters	Inches
<b>A</b>	200	7.87
<b>B</b>	50	1.97

8.4.4 Cable CBM200

---



**Fig. 8-10** Power Supply Cable CBM200

Dim	Millimeters	Inches
<b>A</b>	100	3.94

## 9 Ordering Information

### 9.1 XETK-V1.0

Type	Order-No.	Note
XETK-V1.0A	F-00K-105-755	XETK-V1.0 emulator probe with 1 MByte emulation memory per page, for Freescale MPC5500 - VertiCal Base Boards; standard XETK-V1.0 variant
XETK-V1.0B	F-00K-105-756	XETK-V1.0 emulator probe with 1 MByte emulation memory per page, for Freescale MPC5500 - VertiCal Base Boards, with holes for fixing the XETK inside the ECU

### 9.2 VertiCal Base Boards

#### Note

VertiCal base boards are available from your local Freescale Semiconductor distributors.

#### Part Numbering System

Key						
1	2	3	4	5	6	7
XX	VBB		MXX	X	X	X

Key	Description	Option
1	Solder ball material	LF: Lead free SC: Lead (conventional)
2	VertiCal base board	VBB
3	Optional balls	O: Optional balls fitted
4	Fitted device	M34: MPC5534 M53: MPC5553 M54: MPC5554 Mnn: MPC55nn
5	Footprint	Q: 208 footprint U1: 324 footprint W: 416 footprint
6	Lower board side fitting	S: Solder Balls A: Pin Array
7	Shipping	RL: Tape and Reel T: Tray

**Example:** LFVBBOM54WA

Lead-Free VertiCal base with 416 Pin Array footprint fitted with optional balls and MPC5554 silicon

**Note**

*Not all option variants may be available.*

### 9.3 Sockets ECU - VertiCal Base Board

---

For mounting a VertiCal base board with pin array, a socket must be used on the ECU. Please contact your local Freescale Semiconductor distributor for further information on required sockets.

### 9.4 Power Supply

---

Order Name	Short Name	Order Number
ETK power supply for 6 - 36 V DC input	ETP1	F 00K 000 624
Power Supply Interface for ETK	ETP2	F 00K 104 010



## 9.5 Cables

---

### **Note**

*The cables showed in chapter "Cables and Accessories" on page 59 are not included in the XETK-V1.0 delivery.*

### **Note**

*The screws for mounting ECU adapter cables are not included in the cable delivery. They need to be ordered separately.*

### 9.5.1 ECU Adapter Cables

---

<b>Order Name</b>	<b>Short Name</b>	<b>Order Number</b>
XETK ECU Adapter Cable, 100 Mbit/s, Shield on ECU-Housing, Lemo 1B HME - JST PHE (10fc-5fc), 0m38	CBAM230.1-0m38	F 00K 105 791
XETK ECU Adapter cable, 100 MBit/s, Lemo 1B HME - JST PHE (10fc-5fc), 0m6	CBAM240.1-0m6	F 00K 105 792

### 9.5.2 Ethernet Cables

---

#### *PC Interface Cables*

---

<b>Order Name</b>	<b>Short Name</b>	<b>Order Number</b>
Ethernet PC Connection Cable 1GBit/s, Lemo 1B FGE - RJ45 (10mc-8mc), 3 m	CBE200-3	F 00K 104 373
Ethernet PC Connection Cable 1GBit/s, Lemo 1B FGE - RJ45 (10mc-8mc), 5 m	CBE200-5	F 00K 105 171
Ethernet PC Connection Cable 1GBit/s, Lemo 1B FGE - RJ45 (10mc-8mc), 8 m	CBE200-8	F 00K 104 374
Ethernet PC Connection Cable 1GBit/s, Lemo 1B FGE - RJ45 (10mc-8mc), 20 m	CBE200-20	F 00K 104 372
Ethernet Connection Adapter Cable 1 GBit/s, Lemo 1B PHE - RJ45 (10fc-8mc), 1m20	CBAE200.2-1m20	F 00K 105 760

*ES600 / ES910 Interface Cable*

<b>Order Name</b>	<b>Short Name</b>	<b>Order Number</b>
Ethernet Connection Cable 1 GBit/s, Lemo 1B FGE - Lemo 1B FGE (10mc-10mc), 3 m	CBE230.1-3	F 00K 105 757
Ethernet Connection Cable 1 GBit/s, Lemo 1B FGE - Lemo 1B FGE (10mc-10mc), 8 m	CBE230.1-8	F 00K 105 758
Ethernet Connection Cable 1 GBit/s, Lemo 1B FGE - Lemo 1B FGE (10mc-10mc), 12 m	CBE230.1-12	F 00K 106 360
Ethernet Connection Cable 1 GBit/s, Lemo 1B FGE - Lemo 1B FGE (10mc-10mc), 20 m	CBE230.1-20	F 00K 106 361

*ES600 Interface Adapter Cable*

<b>Order Name</b>	<b>Short Name</b>	<b>Order Number</b>
Ethernet Connection Adapter Cable 1 GBit/s to 100 MBit/s, Lemo 1B PHE - Lemo 1B FGF (10fc-8mc), 0m5	CBAE330.2-0m5	F 00K 105 759

## 9.5.3 Power Supply Cables

<b>Order Name</b>	<b>Short Name</b>	<b>Order Number</b>
Cable JST PHR - JST PHR (2fc-3fc), 0m1	CBM200-0m1	F 00K 900 052
ETK Power Supply Cable, JST PHR - open wires (2fc-2c) 0m19	ETV	Y 261 A24 446
External Power Supply Cable for ETKs, Lemo 0B FGG # open wires (2fc-1c), 2 m	K70	Y 261 A24 942
ETK Power Supply Cable for External Supply, with Filter Coil, Lemo 0B EGG # open wire (2fc-1c), 0m2	KA50	F 00K 000 940

## 10 ETAS Contact Addresses

---

### *ETAS HQ*

---

ETAS GmbH

Borsigstraße 24

70469 Stuttgart

Germany

Phone: +49 711 3423-0

Fax: +49 711 3423-2106

WWW: [www.etas.com](http://www.etas.com)

### *ETAS Subsidiaries and Technical Support*

---

For details of your local sales office as well as your local technical support team and product hotlines, take a look at the ETAS website:

ETAS subsidiaries WWW: [www.etas.com/en/contact.php](http://www.etas.com/en/contact.php)

ETAS technical support WWW: [www.etas.com/en/hotlines.php](http://www.etas.com/en/hotlines.php)

---

## List of Figures

<b>Fig. 2-1</b>	Adhesive Label (Example: Label for XETK-S14.0) .....	11
<b>Fig. 2-2</b>	WEEE-Symbol .....	12
<b>Fig. 3-1</b>	XETK-V1.0A (left) and XETK-V1.0B (right) .....	14
<b>Fig. 4-1</b>	VertiCal Interface Concept (Side View).....	17
<b>Fig. 4-2</b>	VertiCal Base Board .....	18
<b>Fig. 4-3</b>	VertiCal Base Board (fitted with Solder Balls, Side View).....	18
<b>Fig. 4-4</b>	VertiCal Base Board (fitted with Pin Array/ BGA Adapter, Side View) .....	18
<b>Fig. 4-5</b>	XETK-V1.0 .....	19
<b>Fig. 4-6</b>	System with internal and external Memory (e.g. MPC5553, MPC5554).....	20
<b>Fig. 4-7</b>	System with internal and external Memory (e.g. MPC5534) .....	21
<b>Fig. 4-8</b>	Data Emulation and Measurement Data Memory: 2 Pages with 1 MByte each 22	
<b>Fig. 4-9</b>	Division of the 128 Byte Trigger Segment .....	23
<b>Fig. 4-10</b>	Power Supply Connectors CON2 and CON3 .....	25
<b>Fig. 4-11</b>	Power Supply monitoring.....	25
<b>Fig. 4-12</b>	Power Supply Connector CON2 .....	25
<b>Fig. 4-13</b>	Location of the Ethernet Interface.....	27
<b>Fig. 4-14</b>	Location of the Nexus (JTAG) Interface.....	28
<b>Fig. 4-15</b>	Nexus (JTAG) TOOL_IO0 Signal Flow .....	28
<b>Fig. 4-16</b>	Status LEDs.....	29
<b>Fig. 5-1</b>	XETK-V1.0 soldered Connection to the ECU .....	32
<b>Fig. 5-2</b>	XETK-V1.0 Connection to the ECU with Socket/Adapter .....	33
<b>Fig. 5-3</b>	Wiring - XETK Ethernet Interface.....	34
<b>Fig. 5-4</b>	Wiring - Permanent Power Supply inside ECU available .....	35
<b>Fig. 5-5</b>	Wiring - Permanent Power Supply inside ECU not available.....	35
<b>Fig. 5-6</b>	Wiring - Isolated Power Supply inside ECU .....	35
<b>Fig. 7-1</b>	Read Cycle: Data Emulation and Measurement Data DPR .....	47
<b>Fig. 7-2</b>	Write Cycle: Data Emulation and Measurement Data DPR .....	47

<b>Fig. 7-3</b>	XETK-V1.0A Dimensions - Top View .....	49
<b>Fig. 7-4</b>	Mechanical Dimensions XETK-V1.0A: Microcontroller with Socket Adapter mounted .....	49
<b>Fig. 7-5</b>	XETK-V1.0B Dimensions - Top View .....	50
<b>Fig. 7-6</b>	Mechanical Dimensions XETK-V1.0B: Microcontroller with Socket Adapter mounted .....	51
<b>Fig. 7-7</b>	Vertical Connector .....	52
<b>Fig. 8-1</b>	CBAM230.1 Adapter Cable .....	59
<b>Fig. 8-2</b>	CBAM240.1 Adapter Cable .....	59
<b>Fig. 8-3</b>	CBE200-x Cable .....	60
<b>Fig. 8-4</b>	CBAE200.2 Adapter Cable.....	60
<b>Fig. 8-5</b>	CBE230.1 Cable .....	61
<b>Fig. 8-6</b>	CBAE330.2 Adapter Cable.....	61
<b>Fig. 8-7</b>	Power Supply Cable ETV .....	61
<b>Fig. 8-8</b>	Power Supply Cable K70 .....	62
<b>Fig. 8-9</b>	Power Supply Cable KA50 .....	62
<b>Fig. 8-10</b>	Power Supply Cable CBM200 .....	62

---

## Index

**A**

Acquisition 22  
Applications 14  
Architecture 19

**B**

Blockdiagram 19  
Braindead Flash 30

**C**

Cable 62  
    Power Supply 61  
Cable CBM200 62  
Cable ETV 61  
Cable K70 62  
Cable KA50 62  
CBAE200.1 Adapter Cable 60  
CBAE330.1 Adapter Cable 61  
CBAM230.1 Adapter Cable 59  
CBAM240.1 Adapter Cable 59  
CBE200-x Cable 60  
CBE230.1 Cable 61  
Code  
    Flash Memory 24  
Code Flash Memory 24  
Configuration 40  
Configuration Parameter 36

**D**

Data Emulation Memory 22

Data Flash Memory 24  
Data Retention 24  
Default IP address 41  
Documentation 8

**E**

ECU Adapter Cable 59  
Electrical Characteristics 43  
Environmental Conditions 40  
ETAS Contact Addresses 67  
ETAS Hardware 39

**F**

Features 15

**H**

Hardware Description 17

**I**

Identifications on the product 11  
INCA 36, 41  
Interface  
    Microcontroller 20  
    Nexus (JTAG) 28  
Introduction 14  
Isolated Power Supply 35

**L**

LED 29

**M**

Measurement Data  
    Capture 22  
Measurement Data Memory 22  
Mechanical Dimension 49  
Memory  
    Code 24  
Microcontroller Bus Interface 42  
Microcontroller Interface 20

**N**

Network Card 41  
Nexus Connector 57

**O**

Operation  
    Conventions 7  
    Use Case 6  
Ordering Information 63

**P**

Part Numbering Codes 63  
PC Interface Cable 60  
PC Network Card 39  
PCMCIA Network Card 39  
Pin Assignment 52  
Power Supply 25, 35, 64  
Power Supply Cables 66  
Power Supply Connector 25  
Power-saving Mode 39  
Presentation of information 6  
Product  
    Exclusion of liability 8  
Product Back 12  
Program Code 24  
Protocol 41

**R**

Rapid Prototyping 41  
REACH regulation (EU) 13  
Read Timing 47  
Recycling 12  
Reset 31  
RoHS conformity  
    China 12  
    European Union 12

**S**

Safety notices  
    Identification 6  
Safety precautions 8  
Scope of supply 7

Sockets ECU - VertiCal Base Board 64  
Software Support 39  
Status LED 29  
Supported Microcontroller 39  
Switching Characteristic 47  
System Requirements 39

**T**

Testcharacteristics 42  
Timing  
    Read 47  
    Write 47  
Trigger Segment 23  
Triggering 22

**U**

Use, intended 8

**V**

VertiCal 21  
VertiCal Base Board 18  
VertiCal base board 17  
VertiCal Connector 21  
VertiCal Interface Concept 17  
VertiCal top board 17

**W**

Waste Electrical and Electronic Equip-  
    ment 12  
WEEE 12  
WEEE take-back system 12  
Wiring 34  
Write Timing 47

**X**

XETK Configuration 36  
XETK Configuration Tool 41  
XETK Ethernet Interface 27, 34, 41