

Two red lines intersect on a blue background. One line starts from the top right and goes down to the left. The other line starts from the top left and goes down to the right. They intersect at a point marked with a small white circle. A second red line segment extends from this intersection point towards the bottom left, ending in another small white circle.

ETP2

Power Supply Interface for ETK

User Guide

Copyright

The data in this document may not be altered or amended without special notification from ETAS GmbH. ETAS GmbH undertakes no further obligation in relation to this document. The software described in it can only be used if the customer is in possession of a general license agreement or single license. Using and copying is only allowed in concurrence with the specifications stipulated in the contract.

Under no circumstances may any part of this document be copied, reproduced, transmitted, stored in a retrieval system or translated into another language without the express written permission of ETAS GmbH.

© **Copyright 2022** ETAS GmbH, Stuttgart

The names and designations used in this document are trademarks or brands belonging to the respective owners.

ETP2 - User Guide R04 EN - 09 2022

Contents

1	About this Document	5
1.1	Classification of Safety Messages	5
1.2	Presentation of Instructions	5
1.3	Scope of Supply	5
1.4	Additional Information	6
2	Basic Safety Notices	7
2.1	General Safety Information	7
2.2	Requirements for Users and Duties for Operators	7
2.3	Intended Use	7
2.4	Identifications on the Product	11
2.5	Taking the Product Back and Recycling	12
2.6	CE Declaration of Conformity (European Union)	12
2.7	UKCA Declaration of Conformity (Great Britain)	12
2.8	RoHS Conformity	12
	2.8.1 European Union	12
	2.8.2 China	13
2.9	Declarable Substances	13
2.10	Use of Open Source Software	13
3	Introduction	14
3.1	General Safety Instructions	14
3.2	Applications	14
3.3	Features	14
4	Hardware Description	15
4.1	Architecture	15
4.2	Application	15
4.3	Power Supply	16
4.4	Connector Layout	16
	4.4.1 DC Input	16
	4.4.2 DC Output	16
4.5	Cabling	17
5	Technical Data	18
5.1	Power Supply	18
5.2	Environmental Conditions	18
5.3	Pin Assignment	18
	5.3.1 Connector J1 (Input)	18
	5.3.2 Connector J2 (Output)	19
5.4	Mechanical Dimensions	19

6	Cables	20
6.1	Cable CBM200-0m1	20
6.2	Cable ETV	20
6.3	Cable with Filtercoil ETV2.	20
7	Ordering Information	21
7.1	ETP2.	21
7.2	Cables	21
8	Contact Information	22
	Figures	23
	Index	24

1 About this Document

1.1 Classification of Safety Messages

The safety messages used here warn of dangers that can lead to personal injury or damage to property:



DANGER

indicates a hazardous situation with a high risk of death or serious injury if not avoided



WARNING

indicates a hazardous situation of medium risk which could result in death or serious injury if not avoided.



CAUTION

indicates a hazardous situation of low risk which may result in minor or moderate injury if not avoided.

NOTICE

indicates a situation which may result in damage to property if not avoided.

1.2 Presentation of Instructions

The target to be achieved is defined in the heading. The necessary steps for this are in a step-by-step guide:

Target definition

1. Step 1
 2. Step 2
 3. Step 3
- > Result

Presentation of Supporting Information



NOTE

Contains additional supporting information.

1.3 Scope of Supply

Prior to the initial commissioning of the module, please check whether the product was delivered with all required components and cables (see chapter "Ordering Information").

Additional cables and adapters can be obtained separately from ETAS. A list of accessories and their order designation is available in this manual and at the ETAS Home Page.

1.4 **Additional Information**

The configuration instructions for the product can be found in the corresponding software documentation.

2 Basic Safety Notices

This chapter contains information about the following topics:

- "General Safety Information" on page 7
- "Requirements for Users and Duties for Operators" on page 7
- "Intended Use" on page 7
- "Identifications on the Product" on page 11
- "Taking the Product Back and Recycling" on page 12
- "CE Declaration of Conformity (European Union)" on page 12
- "UKCA Declaration of Conformity (Great Britain)" on page 12
- "RoHS Conformity" on page 12
- "Declarable Substances" on page 13
- "Use of Open Source Software" on page 13

2.1 General Safety Information

Please observe the Product Safety Notices ("ETAS Safety Notice") and the following safety notices to avoid health issues or damage to the device.



NOTE

Carefully read the documentation (Product Safety Advice and this User's Guide) that belongs to the product prior to the startup.

ETAS GmbH does not assume any liability for damages resulting from improper handling, unintended use or non-observance of the safety precautions.

2.2 Requirements for Users and Duties for Operators

The product may be assembled, operated and maintained only if you have the necessary qualification and experience for this product. Incorrect operation or operation by users without sufficient qualification may lead to injuries or death or property damages.

General Safety at Work

The existing regulations for safety at work and accident prevention must be followed. All applicable regulations and statutes regarding operation must be strictly followed when using this product.

2.3 Intended Use

An ETK is an electronic component that is installed in a vehicle control unit (ECU) to read data from the ECU or write data to the ECU.

Application Area of the Product

This product was developed and approved for automotive applications. For use in other application areas, please contact your ETAS contact partner.

Requirements for Operation

The following requirements are necessary for safe operation of the product:

- Use the product only according to the specifications in the corresponding User's Guide. With any deviating operation, the product safety is no longer ensured.
- Observe the regulations applicable at the operating location concerning electrical safety as well as the laws and regulations concerning work safety!
- Do not apply any voltages to the connections of the product that do not correspond to the specifications of the respective connection.
- Connect only current circuits with safety extra-low voltage in accordance with EN 61140 (degree of protection III) to the connections of the product.
- The power supply for the product must be safely disconnected from the supply voltage. For example, use a car battery or a suitable lab power supply.
- Use only lab power supplies with double protection to the supply system.
- Ensure that the connections of the power supply are easily accessible.
- The module does not have an operating voltage switch.
 - Switch on the product by connecting the power supply cable with the power supply or by switching on the power supply.
 - Switch off the product by disconnecting it from the power supply or by switching off the power supply



DANGER

Connect the power cord only with a vehicle battery or with a lab power supply! A connection to power outlets is prohibited.

Route the power cord in such a way that it is protected against abrasion, damages, deformation and kinking. Do not place any objects on the power cord.

Never apply force to insert a plug into a socket. Ensure that there is no contamination in and on the connection, that the plug fits the socket, and that you correctly aligned the plugs with the connection.

Do not use the product in a wet or damp environment.

Do not use the product in potentially explosive atmospheres.

Keep the surfaces of the product clean and dry.

Potential Equalization



CAUTION

Danger from inadvertent current flow!

Depending on the design, the shield of the Ethernet cables can be connected with the housing of the module. Install the products only on components with the same electrical potential or isolate the products from the components.

Requirements for the technical State of the Product

The product is designed in accordance with state-of-the-art technology and recognized safety rules. The product may be operated only in a technically flawless condition and according to the intended purpose and with regard to safety and dangers as stated in the respective product documentation. If the product is not used according to its intended purpose, the protection of the product may be impaired.

Maintenance and Cleaning

The product is maintenance-free. Use a lightly moistened, soft, lint-free cloth for cleaning the product. Ensure that no moisture can enter. Never spray cleaning agents directly onto the product. Do not use any sprays, solvents or abrasive cleaners which could damage the product.

Transport and Installation



CAUTION

The ETK can be damaged or destroyed!

Some components of the ETK board may be damaged or destroyed by electrostatic discharges. Please keep the ETK in its storage package until it is installed.

The board should only be taken from its package, configured, and installed at a workplace that is protected against static discharge.



CAUTION

During installation and removal, ECU and ETK must be in a de-energized state!



CAUTION

Risk of short circuiting the internal signals of the ETK!

When you mount the ETK to the ECU, you must ensure that the screws and washers used will not penetrate the ETK printed circuit board.

**CAUTION**

Differences in case ground potentials can cause high currents to flow through the shields of the cables that connect various system modules.

Ensure that the module mounting surfaces are at the same electrical potential or insulate the modules from their mounting surfaces.

Cabling







Use exclusively ETAS cables at the connections of the product! Adhere to the maximum permissible cable lengths! Observe the assignment of the cables to the connectors! Detailed information about cabling is located in the ETK User's Guides.

2.4 Identifications on the Product



Fig. 2-1 Adhesive Label (Example: Label for XETK-S14.0)

The following symbols are used for identifications of the product:

Symbol	Description
	The User's Guide must be read prior to the startup of the product!
	Symbol for WEEE, see chapter 2.5 on page 12
	Symbol for CE conformity, see chapter 2.6 on page 12
	Symbol for UKCA conformity, see chapter 2.7 on page 12
	Symbol for China RoHS, see chapter 2.8.2 on page 13
	Symbol for China RoHS, see chapter 2.8.2 on page 13
	Symbol for electrostatic sensitive components
XETK-S14.0A	Product designation (example)
F 00K 110 722	Order number of the product (example)
SN: yyxxxxx	Serial number (7-digit)
XXXX/YY	Product version
ZZZZ	Year of manufacture
ETAS GmbH,...	Manufacturer's address



NOTE

For symbols and product information one or several adhesive labels can be used.

2.5 Taking the Product Back and Recycling

The European Union has passed a directive called Waste Electrical and Electronic Equipment, or WEEE for short, to ensure that systems are setup throughout the EU for the collection, treating and recycling of electronic waste.

This ensures that the devices are recycled in a resource-saving way representing no danger to health or the environment.



Fig. 2-2 WEEE-Symbol

The WEEE symbol (see Fig. 2-2 on page 12) on the product or its packaging shows that the product must not be disposed of as residual garbage.

The user is obliged to collect the old devices separately and return them to the WEEE take-back system for recycling. The WEEE directive concerns all ETAS devices but not external cables or batteries.

For more information on the ETAS GmbH Recycling software, contact the ETAS sales and service locations.

2.6 CE Declaration of Conformity (European Union)

With the CE mark attached to the product or its packaging, ETAS confirms that the product corresponds to the applicable product-specific European Directives. The CE Declaration of Conformity for the product is available upon request.

2.7 UKCA Declaration of Conformity (Great Britain)

With the UKCA mark attached to the product or its packaging, ETAS confirms that the product corresponds to the product-specific, applicable standards and directives of Great Britain. The UKCA declaration of conformity for the product is available on request.

2.8 RoHS Conformity

2.8.1 European Union

The EU Directive 2011/65/EU limits the use of certain dangerous materials for electrical and electronic devices (RoHS conformity).

This product does not contain any of the restricted substances specified in the EU Directive 2011/65/EU or exceeds the maximum concentrations stipulated therein. For individual electronic components used in our products, there are currently no equivalent alternative substances, which is why we make use of the exception 7C-I in Annex III of this Directive.

ETAS confirms that the product corresponds to this directive which is applicable in the European Union.

2.8.2 China

ETAS confirms that the product meets the product-specific applicable guidelines of the China RoHS (Management Methods for Controlling Pollution Caused by Electronic Information Products Regulation) applicable in China with the China RoHS marking affixed to the product or its packaging.

2.9 Declarable Substances

European Union

Some products from ETAS GmbH (e.g. modules, boards, cables) use components with substances that are subject to declaration in accordance with the REACH regulation (EU) no.1907/2006.

Detailed information is located in the ETAS download center in the customer information "REACH Declaration" (www.etas.com/Reach). This information is continuously being updated.

2.10 Use of Open Source Software

The product uses Open Source Software (OSS). This software is installed in the product at the time of delivery and does not have to be installed or updated by the user. Reference shall be made to the use of the software in order to fulfill OSS licensing terms. Additional information is available in the document "OSS Attributions List" at the ETAS website www.etas.com.

3 Introduction

This section contains general safety instructions, information about the basic features and applications of the ETP2 Power Supply Interface for ETK.

3.1 General Safety Instructions

This manual addresses qualified personnel working in the fields of automobile control unit development and calibration. Specialized knowledge in the areas of measurement and control unit technology is required.

Liability cannot be accepted for damage caused by non adherence to the instructions contained in this document!

 **NOTE**

Some components of the interface board may be damaged or destroyed by electrostatic discharges. Please keep the board in its storage package until it is installed.

The board should only be taken from its package, configured, and installed at a work place that is protected against static discharge.

3.2 Applications

The ETP2 Power Supply Interface for ETK is used as a front end power supply for ETAS ETKs.

3.3 Features

- Input voltage of 4.3 V to 36 V DC (minimum startup voltage is 5 V)
- Output voltage of 12 V DC +/-25 %
- Output current of 0.5 A
- Standby current of 15 mA at 12 V input
- Temperature range: - 40 °C to +110 °C
- Dimensions: 50 x 35 x 12 mm
- Included power supply cable for ETK

4 Hardware Description

In this chapter, the individual function blocks of the ETP2 hardware are explained in detail.

4.1 Architecture

The ETP2 is a device used as the front end power supply for ETAS ETKs. The ETP2 is connected between the vehicle battery and the ETK's power supply connector.

Fig. 4-1 shows the block diagram which illustrates the ETP2 functional blocks.

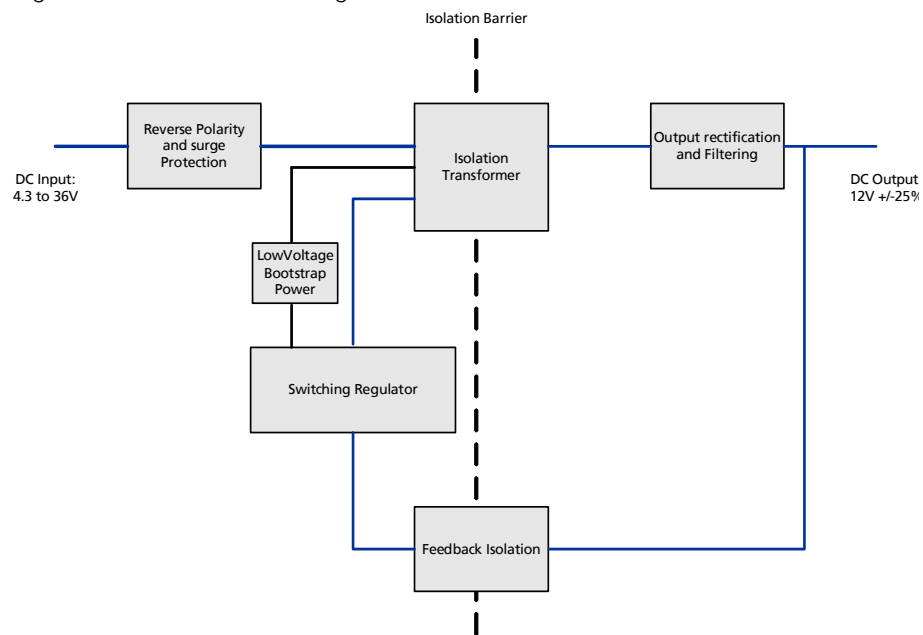

Fig. 4-1 ETP2 Architecture

The ETP2 galvanically isolates the power supply (typically the vehicle battery) from the ETK using a DC-DC converter with an isolation transformer. In addition to galvanic isolation, the ETP2 also extends the ETK input voltage range to a minimum of 4.3 V and a maximum of 36 V (see Chapter "Power Supply" on page 18)."

4.2 Application

Signal integrity can be compromised when the ETK power supply and the ETK signals share the same current paths. Galvanically isolating the ETK from the power supply separates the power supply currents from the ETK signal currents. The result is improved ETK signal integrity and prevents the ETK power supply current from flowing into the ECU.

The ETP2 is powered from its input connector, which is normally the vehicle power supply or battery. The ETP2 transfers the input power via a transformer to the ETK through the ETP2 output connector. The typical output for the ETP2 is 12 V (see Chapter "Power Supply" on page 18). Refer to Fig. 4-3 on page 17 for typical application diagram with an ETK.

4.3 Power Supply

The ETP2 is intended to be powered directly from a permanent power supply (vehicle battery), see Fig. 4-3.

4.4 Connector Layout

The ETP2 has two connectors (see Fig. 4-2).

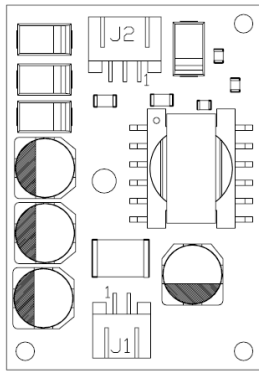

Fig. 4-2 Connector Layout

Connector	Interface
J1	DC input (from vehicle battery)
J2	DC output (to ETK)

Tab. 4-1 ETP2 Interface Connectors

4.4.1 DC Input

The input of the ETP2 is connector "J1". It is connected directly to the vehicle power supply or battery.

4.4.2 DC Output

The output of the ETP2 is connector "J2". It is to be connected to the power supply input (battery input) for the ETK.

4.5 Cabling

The ETP2 is connected between the permanent power supply and the ETK power supply connector (see Fig. 4-3). The ETK is connected to the ETP2 using the CBM200 cable.

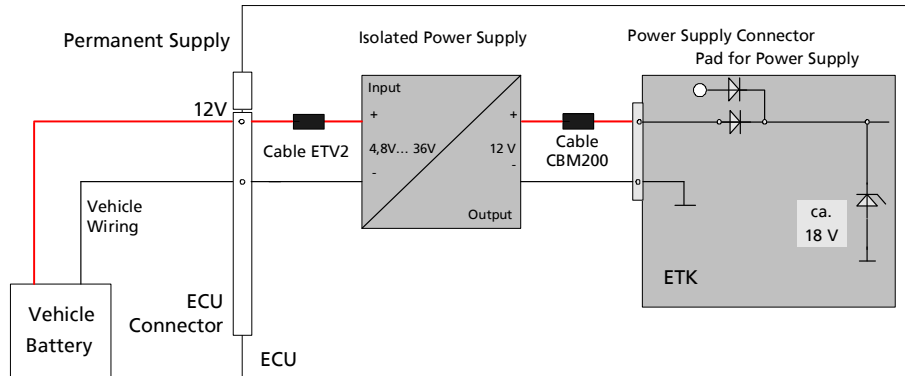

Fig. 4-3 Isolated Power Supply ETP2 inside ECU

5 Technical Data

5.1 Power Supply

Parameter	Symbol	Condition	Min	Typ	Max	Unit
Permanent power supply ¹⁾ (car battery)	V_{in}	T = -40 °C to +110 °C	4.3	12	36	V
ETK supply voltage	V_{out}	-40 °C to +110 °C	9	12	15	V
Supply current	I_{Batt}	$V_{Batt} = 12\text{ V};$ ECU on; T = 20 °C; Load = 25 Ohm			0.9	A
Output current	I_{out}	T = -40 °C to +110 °C		0.5		A
Standby current	I_{STBY}	$V_{Batt} = 12\text{ V};$ ETK off (no load); T = 20 °C			15	mA

¹⁾ Minimum startup voltage for V_{in} is 5 V. Operation down to 4.3 V.

5.2 Environmental Conditions

Item	Characteristics
Temperature range	- 40 °C to + 110 °C - 40 °F to + 230 °F

5.3 Pin Assignment

5.3.1 Connector J1 (Input)

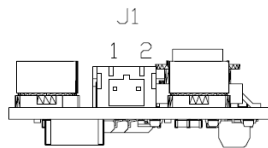

Fig. 5-1 Connector J1 Pinout

Pin	Signal	Description
1	V_{in+}	To battery "+"
2	V_{in-}	To battery "-"

Tab. 5-1 Connector J1 Pin Assignment

5.3.2 Connector J2 (Output)

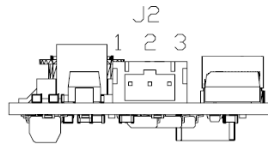

Fig. 5-2 Connector J2 Pinout

Pin	Signal	Description
1	V _{out+}	To ETK "+" (power supply)
2	V _{out-}	To ETK "GND"
3	N/C	Not connected

Tab. 5-2 Connector J2 Pin Assignment

5.4 Mechanical Dimensions

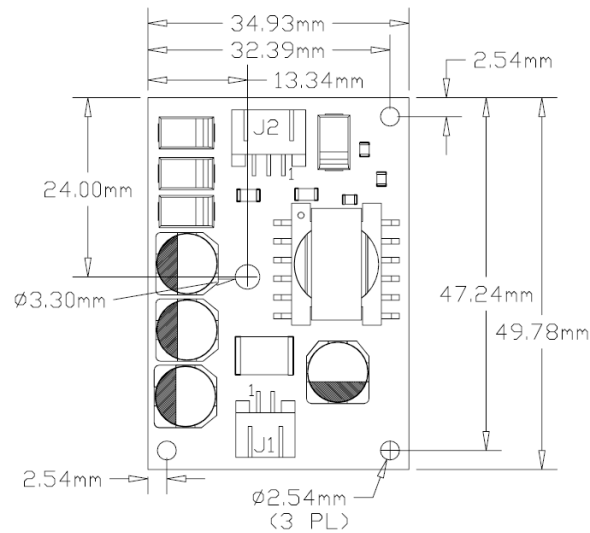

Fig. 5-3 ETP2 Dimensions - Top View

Dimensions	Millimeters	Inches
Length	49.78	1.96
Width	34.93	1.375
Height	max. 13.58	max. 0.513
Thickness of PCB	max. 1.7	max. 0.067
Height of components (upper side)	max. 7.88	max. 0.310
Height of components (lower side)	max. 4.0	max. 0.157

6 Cables

NOTE

The ETP2 to ETK cable (CBM200-0m1) is included in the ETP2 delivery. The ETP2 power cable is not included in the delivery. Either the ETV or ETV2 cables described below should be purchased separately. For order numbers refer to chapter 7 on page 21.

6.1 Cable CBM200-0m1

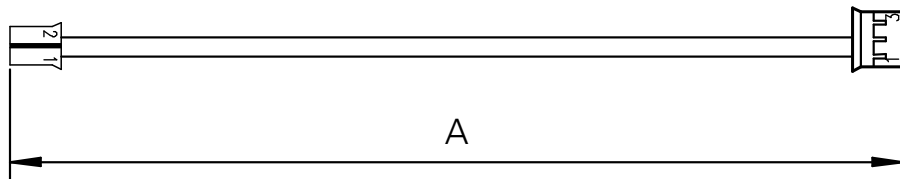

Fig. 6-1 ETP2 to ETK Power Supply Cable CBM200-0m1

Dim	Millimeters	Inches
A	100.00	3.94

6.2 Cable ETV

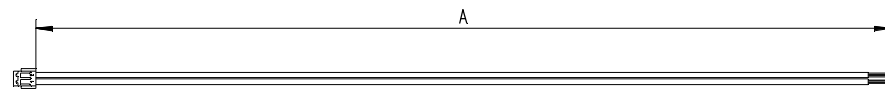

Fig. 6-2 Power Supply Cable ETV

Dim	Millimeters	Inches
A	190.00	7.480

6.3 Cable with Filtercoil ETV2

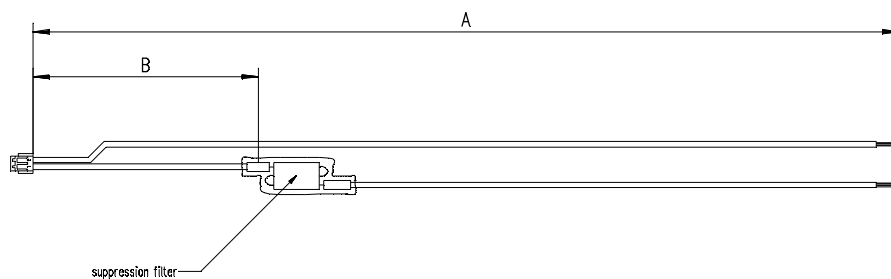

Fig. 6-3 Power Supply Cable with Filtercoil ETV2

Dim	Millimeters	Inches
A	190.00	7.480
B	50.00	1.969

7 Ordering Information

7.1 ETP2

Type	Order-No.	Note
ETP2 Power Supply Interface for ETK	F 00K 104 010	ETP2 with ETK interface cable CBM200-0m1

7.2 Cables

Type	Order-No.	Note
CBM200-0m1	F 00K 900 052	ETP2 to ETK cable
ETV	Y 261 A24 446	Power supply cable
ETV2	F 00K 000 593	Power supply cable with filtercoil

8 Contact Information

ETAS Headquarters

ETAS GmbH

Borsigstraße 24
70469 Stuttgart
Germany

Phone: +49 711 3423-0
Fax: +49 711 3423-2106
Internet: www.etas.com

ETAS Subsidiaries and Technical Support

For details of your local sales office as well as your local technical support team and product hotlines, take a look at the ETAS website:

ETAS subsidiaries Internet: www.etas.com/en/contact.php
ETAS technical support Internet: www.etas.com/en/hotlines.php

Figures

Fig. 2-1	Adhesive Label (Example: Label for XETK-S14.0)	11
Fig. 2-2	WEEE-Symbol	12
Fig. 4-1	ETP2 Architecture	15
Fig. 4-2	Connector Layout	16
Fig. 4-3	Isolated Power Supply ETP2 inside ECU	17
Fig. 5-1	Connector J1 Pinout	18
Fig. 5-2	Connector J2 Pinout	19
Fig. 5-3	ETP2 Dimensions - Top View	19
Fig. 6-1	ETP2 to ETK Power Supply Cable CBM200-0m1	20
Fig. 6-2	Power Supply Cable ETV	20
Fig. 6-3	Power Supply Cable with Filtercoil ETV2	20

Index

A	
Application	15
Applications	14
Architecture	15
C	
Cable	
CBM200-0m1	20
ETV	20
ETV2	20
Cabling	17
CE Conformity	12
Connector J1	18
Connector J2	19
Connector Layout	16
D	
DC Input	16
DC Output	16
Dimensions	19
Documentation	7
E	
Environmental Conditions	18
ETP2 Interface	
Pin Description	16
F	
Features	14
H	
Hardware Description	15
I	
Identifications on the product	11
Introduction	14
O	
Ordering Information	21
P	
Pin Assignment	18
Pins	
ETP2 Interface	16
Power Supply	16, 18
Product	
Exclusion of liability	7
Product Back	12
R	
REACH regulation (EU)	13
Recycling	12
RoHS conformity	
China	13
European Union	12
S	
Safety precautions	7
Scope of supply	5
T	
Technical Data	18
U	
UKCA conformity	12
Use, intended	7
W	
Waste Electrical and Electronic Equipment	
	12
WEEE	12
WEEE take-back system	12