

# ETAS XETK-S16.0

JTAG Emulator Probe for ARM Micro-  
controllers



User Guide

## Copyright

The data in this document may not be altered or amended without special notification from ETAS GmbH. ETAS GmbH undertakes no further obligation in relation to this document. The software described in it can only be used if the customer is in possession of a general license agreement or single license. Using and copying is only allowed in concurrence with the specifications stipulated in the contract.

Under no circumstances may any part of this document be copied, reproduced, transmitted, stored in a retrieval system or translated into another language without the express written permission of ETAS GmbH.

**© Copyright 2024** ETAS GmbH, Stuttgart

The names and designations used in this document are trademarks or brands belonging to the respective owners.

XETK-S16.0 - User Guide R08 EN - 05.2024

## Contents

1	Safety Information.....	6
1.1	Intended Use.....	7
1.2	Classification of Safety Messages.....	7
1.3	Safety Information.....	8
1.3.1	Assembly.....	8
1.3.2	Operation.....	8
1.3.3	Electrical Connection.....	8
1.3.4	Cables and Accessories.....	9
1.3.5	Transport.....	10
1.3.6	Maintenance.....	10
1.4	Identifications on the Product.....	10
1.5	Taking the Product Back and Recycling.....	11
1.6	Declaration of Conformity.....	11
1.6.1	CE Declaration of Conformity (European Union).....	11
1.6.2	UKCA Declaration of Conformity (Great Britain).....	11
1.7	RoHS Conformity.....	11
1.7.1	European Union.....	11
1.7.2	People's Republic of China.....	12
1.8	Declarable Substances.....	12
1.9	Use of Open Source Software.....	12
2	Introduction.....	13
2.1	Applications.....	13
2.2	Features.....	14
2.2.1	General.....	14
2.2.2	Calibration.....	14
2.2.3	3rd party Debugger Interface.....	14
3	Hardware Description.....	15
3.1	Architecture.....	15
3.2	ECU Interface.....	16
3.3	XETK Ethernet Interface.....	17
3.4	Debug Interface.....	18
3.5	Power Supply.....	18
3.6	ECU Voltage Supervisor.....	19
3.7	Status LEDs.....	20
3.8	Data Emulation and Data Measurement.....	21
3.9	XETK-S16.0 JTAG Interface.....	22
3.10	Trigger Modes: Overview.....	23
3.11	Pinless Triggering.....	23
3.11.1	Startup Handshake.....	23
3.11.2	XETK Trigger Generation.....	23
3.12	Timer Triggering.....	23
3.13	Reset.....	24

3.14	Pull CalWakeUp until Startup Handshake .....	24
4	Installation .....	25
4.1	Mounting the XETK-S16.0 to the ECU .....	25
4.1.1	Mechanical connection of the XETK-S16.0 to the ECU Housing .....	25
4.1.2	Mounting the XETK-S16.0 to the ECU metal Housing .....	27
4.2	Electrical Connection to the ECU .....	27
4.3	Wiring .....	29
4.3.1	XETK Ethernet Interface .....	29
4.3.2	Power Supply .....	30
5	XETK Configuration .....	32
5.1	Overview .....	32
5.2	Configuration Parameter .....	33
6	Troubleshooting .....	34
6.1	Problems and Solutions .....	34
6.1.1	No communication between the ECU and ETK .....	34
7	Technical Data .....	35
7.1	System Requirements .....	35
7.1.1	ETAS Compatible Hardware .....	35
7.1.2	PC with one Ethernet Interface .....	35
7.1.3	XETK-S16.0 Software Support .....	36
7.2	Data Emulation and Measurement Memory .....	37
7.2.1	Data Emulation Memory and Microcontroller Support .....	37
7.2.2	Measurement Data Memory .....	37
7.3	Configuration .....	37
7.4	XETK Ethernet Interface .....	38
7.5	Environmental Conditions .....	38
7.6	Power Supply .....	39
7.7	Test Characteristics .....	40
7.8	JTAG Timing Characteristics .....	40
7.8.1	JTAG Timing Diagram .....	40
7.8.2	JTAG Timing Parameters .....	41
7.8.3	Debugger Arbitration Timing Diagram .....	42
7.8.4	Debugger Arbitration Timing Parameters .....	42
7.9	Electrical Characteristics .....	43
7.9.1	ECU Interface Characteristics .....	43
7.9.2	ECU Interface Connector CON1 (5.0 V Interface selected) .....	44
7.9.3	ECU Interface Connector CON1 (3.3 V Interface selected) .....	45
7.9.4	ECU Interface Connector CON1 (1.8 V Interface selected) .....	46
7.9.5	Debugger Interface Connector CON3 .....	47
7.10	Pin Assignment .....	48
7.10.1	ECU Interface Connector CON1 (XETK-S16.0 Side) .....	48
7.10.2	Interface and Power Supply Connector CON4 .....	49
7.10.3	Debugger Interface Connector CON3 .....	49
7.11	Mechanical Dimensions .....	50

## 5 | Contents

8	Cables and Accessories .....	51
8.1	ECU Adapter Cable .....	51
8.1.1	CBAM230 Adapter Cable .....	51
8.1.2	CBAM240 Adapter Cable .....	51
8.1.3	CBAM271 Adapter Cable .....	52
8.2	Combined Interface and Power Supply Cable .....	53
8.3	PC Interface Cable .....	54
8.3.1	CBE200 Cable .....	54
8.3.2	CBAE200 Adapter Cable .....	54
8.4	ETAS Module Interface Adapter Cable .....	55
8.4.1	CBE230 Cable .....	55
8.4.2	CBAE330 Adapter Cable .....	55
8.5	Power Supply Cables .....	56
8.5.1	ETV5 Cable .....	56
8.5.2	Cable K70.1 .....	57
8.5.3	Power Supply Cable KA50 .....	57
8.6	ECU Interface Adapters .....	58
8.6.1	XETK - ECU Adapter ETAM2 .....	58
8.6.2	XETK - ECU Adapter ETAM5 .....	58
8.6.3	XETK - ECU Adapter ETAM9 .....	59
8.6.4	XETK - ECU Adapter ETAN4A .....	59
8.7	Water proof Case ETKS_C3 .....	61
9	Ordering Information .....	62
9.1	XETK-S16.0 .....	62
9.2	XETK - ECU Adapter .....	62
9.3	Power Supply .....	62
9.4	Mounting Material .....	62
9.5	Cables .....	63
9.5.1	ECU Adapter Cables .....	63
9.5.2	Combined ECU Adapter and Power Supply Cables .....	63
9.5.3	Ethernet Cables .....	64
9.5.4	Power Supply Cables .....	64
9.6	Waterproof Case .....	64
10	Contact Information .....	65
	Figures .....	66
	Index .....	68

# 1 Safety Information

This chapter contains information about the following topics:

- Intended Use ..... 7
- Classification of Safety Messages ..... 7
- Safety Information ..... 8
- Identifications on the Product ..... 10
- Taking the Product Back and Recycling ..... 11
- Declaration of Conformity ..... 11
- RoHS Conformity ..... 11
- Declarable Substances ..... 12
- Use of Open Source Software ..... 12

Refer to the following safety instructions and the technical documentation available to download from the ETAS website [www.etas.com](http://www.etas.com). Keep the information provided in a safe place.

Failure to comply with the safety instructions may lead to the risk of damage to life and limb or property. The ETAS Group and its representatives shall not be liable for any damage or injury caused by improper operation or use of the product.

Only use the product if you have read and understood the information concerning safe operation and have the required qualifications and training for this product. If you have questions about safe operation, contact ETAS:

- Technical Support: [www.etas.com/hotlines](http://www.etas.com/hotlines)
- ETAS contact partners by region: [www.etas.com/contact](http://www.etas.com/contact)

The product is only approved for the applications described in the technical documentation. When using and operating this product, all applicable regulations and laws must be observed.

ETAS products made available as beta versions or prototypes of firmware, hardware and/or software are to be used exclusively for testing and evaluation purposes. These products may not have sufficient technical documentation and not fulfill all requirements regarding quality and accuracy for market-released series products. The product performance may therefore differ from the product description. Only use the product under controlled testing and evaluation conditions. Do not use data and results from beta versions without prior and separate verification and validation and do not share them with third parties.

Before starting up the product, check whether there is a Known Issue Report (KIR) for that product version: [www.etas.com/kir](http://www.etas.com/kir) (password: KETASIR). Note the information given in the report.

Program codes or program control sequences that are created or changed via ETAS products, as well as all types of data obtained through the use of ETAS products, must be checked for their reliability and suitability prior to use or distribution. Only use these codes or sequences in public areas (e.g., in road traffic) if you have ensured that the application and product settings are safe through testing in self-contained and designated testing environments and circuits.

This ETAS product allows you to influence safety-relevant systems or data (e.g. in motor vehicles, vehicle components and test benches). In the event of a malfunction or a hazardous situation, it must be possible to put the system into a safe state (e.g., emergency stop or emergency operation).

## 1.1 Intended Use

The product was developed and approved for applications in the automotive sector. Only operate the product as per its specifications. If the product is used in any other way, product safety is no longer ensured.

An emulator probe (ETK) is an electronic assembly that is installed in a vehicle control unit (ECU) to exchange data with ECUs.

### Application Areas

- The product is approved for use in the following areas:
  - ECUs
- Do not operate the product in a wet or damp environment.
- Do not operate the product in potentially explosive atmospheres.

### Technical Condition

The product is designed in accordance with state-of-the-art technology. Only operate the product and its accessories if they are in perfect working order. Shut down a damaged product immediately. The product cannot be repaired. Dispose of the product properly. Do not open or alter the product. Only ETAS may make changes to the product.

## 1.2 Classification of Safety Messages

The safety messages used here warn of dangers that can lead to personal injury or damage to property.:



### **DANGER**

DANGER indicates a hazardous situation that, if not avoided, will result in death or serious injury.



### **WARNING**

WARNING indicates a hazardous situation that, if not avoided, could result in death or serious injury.



### **CAUTION**

CAUTION indicates a hazardous situation that, if not avoided, could result in minor or moderate injury.

**NOTICE**

NOTICE indicates a situation that, if not avoided, could result in damage to property.

### 1.3 Safety Information

#### 1.3.1 Assembly

The product must only be removed from the ESD packaging and installed in a workplace that is protected against static discharges.

Only install, connect, disconnect, and cable ETAS products and components when they are de-energized.

When installing the product, make sure that the fastening elements do not damage the product's printed circuit board or cause a short circuit.

#### Installation Location

**NOTICE**

**Damage to the electronics due to potential equalization**

The cables' shield may be connected to the housing, the ground or the ground for the product's power supply. If there are different ground potentials in the test setup, equalizing currents can flow between the products via the cables' shield.

Take account of different electric potentials in your test setup and take appropriate measures to prevent equalizing currents.

#### 1.3.2 Operation

Only operate the product with the latest firmware. You can find information about updating the firmware in the user guide.

If the firmware update is not completed successfully, try it again. If a new firmware update is not possible and the product is not functional, send the product to ETAS.

#### 1.3.3 Electrical Connection

##### Electrical Safety and Power Supply

- Only connect the product to electric circuits with safety extra-low voltage in accordance with IEC 61140 (devices of class III) within the voltage limits for accessible parts as per IEC 61010-1.
- Comply with the connection and setting values (see "Technical Data" on page 35).
- The power supply for the product must be safely disconnected from the mains power. For example, use a car battery or a suitable lab power supply.
- Only use lab power supplies with dual protection for the supply network (with double/reinforced insulation (DI/RI)).
- The power supply must be suitable for use according to the ambient conditions for the product.



- It is possible to discharge the vehicle battery in regular operation and long standby operation.
- Central load-dump protection is required for operation.

### Connection to the power supply



#### **DANGER**

##### **Undefined vehicle behavior due to an ECU reset**

If the external power supply to the ETK is interrupted (e.g. cut, disconnected, etc.), this may lead to the ECU being reset.

- Connect the internal power supply of the ECU to the ETK in addition to the external power supply.
- If this is not possible, ensure that the external power supply to the ETK is not interrupted during operation.



#### **WARNING**

Risk to life from electric shock

If an unsuitable power supply is used, this may generate a hazardous electrical voltage.

- Use a power supply that is permitted for the product.

- Ensure that the connections of the power supply are easily accessible.

### De-energizing the product

1. Disconnect the product from the power supply in one of the following ways:
  - Switch off the laboratory power supply for the test setup.
  - Disconnect the test setup's connection to the vehicle battery.
  - Remove the power cord.
2. Remove all cables from the product.

## 1.3.4 Cables and Accessories

### Cables

- Only use ETAS cables, cables recommended by ETAS or other cables certified for the application.
- Route the cables such that they are protected against abrasion, damage, deformation and kinking.
- Do not place any objects on the cables.
- Do not use any damaged cables.
- The connector and connection must not be dirty.
- The connector and connection must be compatible.
- Correctly align the connector with the connection.
- Do not connect the connector and connection by force.

### Accessories

Use ETAS accessories, accessories recommended by ETAS or other accessories certified for the application. For detailed information about accessories, see "Cables and Accessories" on page 51.

#### 1.3.5 Transport

- Only transport and store the product in ESD packaging.
- Only transport the product individually.
- Do not transport the product by the connected cables.

#### 1.3.6 Maintenance







The product is maintenance-free.

#### Cleaning

- Only clean the product when it is de-energized.
- Make sure that no moisture enters the product.
- Carefully vacuum off dust particles and loose foreign bodies.

### 1.4 Identifications on the Product

The following symbols are used for identifications of the product:

Symbol	Description
	The User Guide must be read prior to the startup of the product!
	Symbol for WEEE, see chapter 1.5 on page 11
	Symbol for CE conformity, see chapter 1.6.1 on page 11
	UKCA conformity symbol (Great Britain), see chapter 1.6.2 on page 11)
	Symbol for China RoHS, see chapter 1.7.2 on page 12
	Symbol for electrostatic sensitive components
XETK-S14.0A	Product designation (example)
F 00K 110 722	Order number of the product (example)
SN: yyxxxxx	Serial number (7-digit)
XXXX/YY	Product version
ZZZZ	Year of manufacture
ETAS GmbH,...	Manufacturer's address

**NOTE**

For symbols and product information one or several adhesive labels can be used.

## 1.5 Taking the Product Back and Recycling

The European Union has passed a directive called Waste Electrical and Electronic Equipment, or WEEE for short, to ensure that systems are setup throughout the EU for the collection, treating and recycling of electronic waste.

This ensures that the devices are recycled in a resource-saving way representing no danger to health or the environment.



**Fig. 1-1** WEEE-Symbol

The WEEE symbol (see Fig. 1-1 on page 11) on the product or its packaging shows that the product must not be disposed of as residual garbage.

The user is obliged to collect the old devices separately and return them to the WEEE take-back system for recycling. The WEEE directive concerns all ETAS devices but not external cables or batteries.

For more information on the ETAS GmbH Recycling software, contact the ETAS sales and service locations.

## 1.6 Declaration of Conformity

### 1.6.1 CE Declaration of Conformity (European Union)

With the CE mark attached to the product or its packaging, ETAS confirms that the product corresponds to the applicable product-specific European Directives. The CE Declaration of Conformity for the product is available upon request.

### 1.6.2 UKCA Declaration of Conformity (Great Britain)

With the UKCA mark attached to the product or its packaging, ETAS confirms that the product corresponds to the product-specific, applicable standards and directives of Great Britain. The UKCA declaration of conformity for the product is available on request.

## 1.7 RoHS Conformity

### 1.7.1 European Union

The EU Directive 2011/65/EU limits the use of certain dangerous materials for electrical and electronic devices (RoHS conformity).

This product does not contain any of the restricted substances specified in the EU Directive 2011/65/EU or exceeds the maximum concentrations stipulated therein. For individual electronic components used in our products, there are currently no equivalent alternative substances, which is why we make use of the exception 7C-I in Annex III of this Directive.

ETAS confirms that the product corresponds to this directive which is applicable in the European Union.

### 1.7.2 People's Republic of China

ETAS confirms that the product meets the product-specific applicable guidelines of the China RoHS (Management Methods for Controlling Pollution. Caused by Electronic Information Products Regulation) applicable in China with the China RoHS marking affixed to the product or its packaging.

## 1.8 Declarable Substances

### European Union

Some products from ETAS GmbH (e.g. modules, boards, cables) use components with substances that are subject to declaration in accordance with the REACH regulation (EU) no.1907/2006.

Detailed information is located in the ETAS download center in the customer information "REACH Declaration" ([www.etas.com/Reach](http://www.etas.com/Reach)). This information is continuously being updated.

## 1.9 Use of Open Source Software

The product uses Open Source Software (OSS). This software is installed in the product at the time of delivery and does not have to be installed or updated by the user. Reference shall be made to the use of the software in order to fulfill OSS licensing terms. Additional information is available in the document "OSS Attributions List" at the ETAS website ([www.etas.com](http://www.etas.com)).

## 2 Introduction

This chapter contains information about the following topics:

- Applications..... 13
- Features ..... 14

### 2.1 Applications

The XETK-S16.0 is a JTAG Emulator Probe for ARM Microcontrollers.

 **NOTE**

For supported ARM microcontrollers, refer to chapter 7.1.3 on page 36.

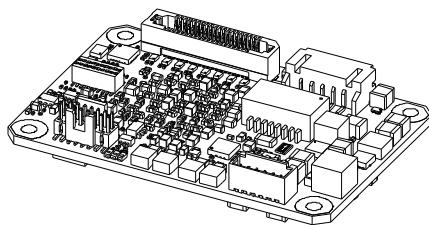

**Fig. 2-1** XETK-S16.0

	XETK-S16.0
XETK ECU interface connectors	40 pin Samtec plus 6pin Molex
Power supply for FCC devices (VDDSTBY)	Configurable 1.09 V or 1.25 V
SBRAM sense	Yes, on board or external sense
Pinless triggering	Yes
Timer triggering	Yes

The XETK-S16.0 supports the standard full duplex 100Base-T Ethernet interface and can be connected directly or via ES51x/ES59x/ES600/ES89x/ES910 modules to the PC. No additional ETAS modules are required for the access to the ECU. The XETK-S16.0 can be used for rapid prototyping applications (bypass) as well as for measurement and calibration applications.

## 2.2 Features

### 2.2.1 General

- 100 Mbit/s Ethernet Interface:
  - Direct connection to PC
  - Open XCP on Ethernet Protocol supporting a variety of standard applications
- XETK-S16.0 JTAG Interface:
  - Configurable JTAG output levels: 1.8V, 3.3V or 5.0V
  - Configurable JTAG interface clock speed: 10MHz, 20MHz, 30MHz or 40MHz
  - JTAG Signals available on the 40 Pin Samtec connector
  - Pinless startup protocol for XETK recognition and data acquisition triggering
  - Measurement raster down to 100  $\mu$ s
- "ETK Drivers and Tools" update to support ETAS software tools (INCA, XCT)
- Firmware update (programming of the logic device) through HSP software service packs; removal of XETK or ECU is not necessary
- Mounting possibilities inside or on top of ECU
- ECU flashing via XETK
  - Braintead flashing under ProF control
- Permanent storage of configuration in EEPROM
- Temperature range suitable for automotive application

### 2.2.2 Calibration

- Concurrent use of calibration and measurement performed via microcontroller
- Working Page & Reference Page (2 page concept) realized by microcontroller overlay mechanism
- Microcontroller capability of internal Flash emulation can be used
- XETK powers Emulation Device RAM (for calibration purpose)
- Supports "Start on Any Page"
- Supports special coldstart mechanism ("Calibration Wake Up"):
  - Calibration Wake Up: Wake up mechanism to wake up the power supply of the ECU via the Calibration Wake up pin
  - Pull CalWakeUp until Startup Handshake: duration of the Wake up mechanism is configurable

### 2.2.3 3rd party Debugger Interface

- XETK provides additional connector for external JTAG debug hardware
- Simultaneously use XETK and JTAG debugger

For more technical data on the XETK-S16.0, consult the chapter "Technical Data" on page 35.

### 3 Hardware Description

This chapter contains information about the following topics:

- Architecture ..... 15
- ECU Interface ..... 16
- XETK Ethernet Interface ..... 17
- Debug Interface ..... 18
- Power Supply ..... 18
- ECU Voltage Supervisor ..... 19
- Status LEDs ..... 20
- Data Emulation and Data Measurement ..... 21
- XETK-S16.0 JTAG Interface ..... 22
- Trigger Modes: Overview ..... 23
- Pinless Triggering ..... 23
- Timer Triggering ..... 23
- Reset ..... 24
- Pull CalWakeUp until Startup Handshake ..... 24

#### 3.1 Architecture

Fig. 3-1 shows the block diagram of the XETK-S16.0.

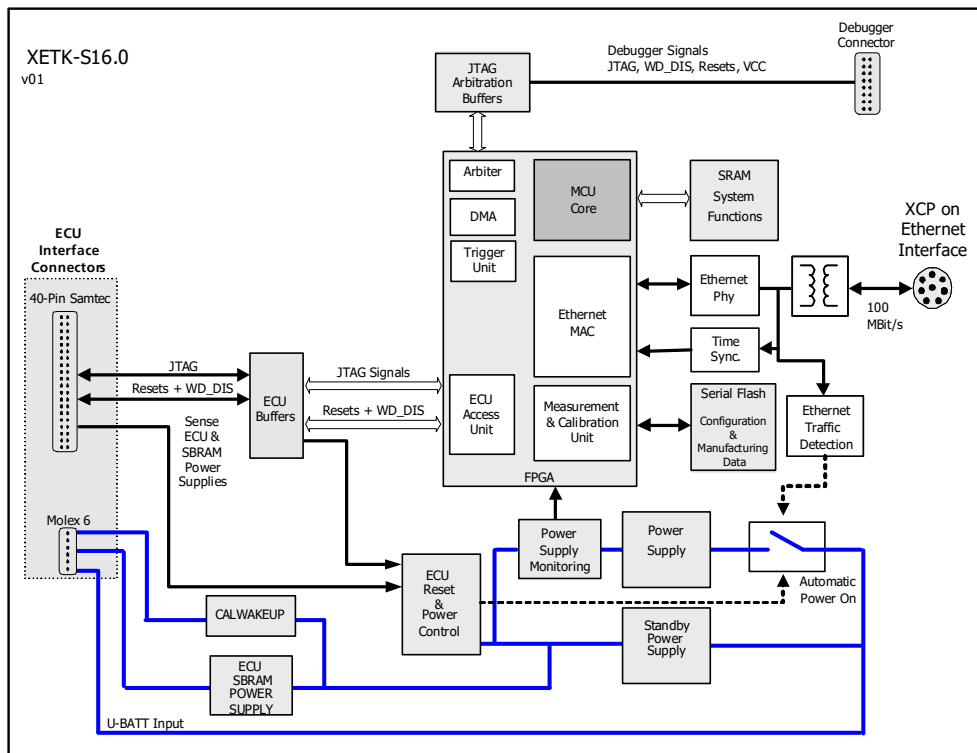

**Fig. 3-1** XETK-S16.0 Architecture

While the microcontroller accesses the program data (not the program code) out of the data emulation memory provided by the microcontroller, the content of the data emulation memory can simultaneously be modified by the calibration and

development system through the XETK Ethernet interface. This process enables adjustments of parameters, characteristic lines and maps through the calibration and development system.

Using an additional measurement data memory area, the ECU microcontroller can provide data to the calibration and development system by buffering the data (DISTAB) and triggering the XETK to read the data via JTAG. The XETK then reads, buffers, processes and sends this measured data to the PC.

The 100 Mbit/s XETK Ethernet interface provides communication with the PC.

The power supply for the XETK-S16.0 is provided by a switch mode power supply, to minimize power dissipation.

### 3.2 ECU Interface

The XETK-S16.0 is connected via connectors CON1 and CON4 to the ECU with two adapter cables (refer to Fig. 3-2 on page 16). The pin definition depends on the application and the microcontroller type. In general the ECU interface consists of

- 1 ECU voltage line, which is not used for XETK power supply, but only for detection of the ECU status, therefore the power consumption on this line is negligible (refer to chapter 3.5 on page 18)
- 1 Reset line which allows the XETK to control the system reset of the ECU
- 1 Reset line which allows the XETK to monitor the system reset of the ECU
- 5 JTAG Debug line interfaces for the communication between the XETK-S16.0 and the microcontroller
- 1 Watchdog timer disable line
- 7 ground lines for proper shielding of the ECU interface lines

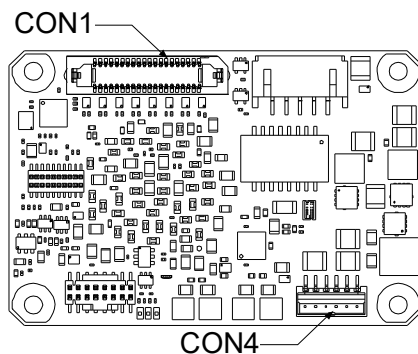

**Fig. 3-2** Location of the ECU Interface connectors



### 3.3 XETK Ethernet Interface

The XETK Ethernet interface can be directly connected to the PC via CON2 (refer to Fig. 3-3). No additional ETAS module is required for the access to the ECU.

The interface is a standard full duplex 100Base-TX Ethernet interface using the XCP protocol. The XETK Ethernet interface is integrated in the ETAS IP world with automatic IP management and supports the open automotive "Universal Measurement and Calibration" standard "XCP on Ethernet" (TCP/IP, UDP/IP). The open XCP on Ethernet interface allows for connecting to the XETK-S16.0 with third party application software.



#### NOTE

The XETK Ethernet interface is not compatible with the ETK interfaces in modules like e.g. ES910, ES591, ES592, ES593-D, ES595. The XETK Ethernet interface is compatible with the ECU interface of the ES910 module and the Ethernet interfaces of the ES51x/ ES592/ ES593-D/ ES595/ ES600/ES88x/ES89x modules.



#### NOTE

Please see chapter 7.1.2 on page 35 for additional information regarding PC requirements for the Ethernet interface.

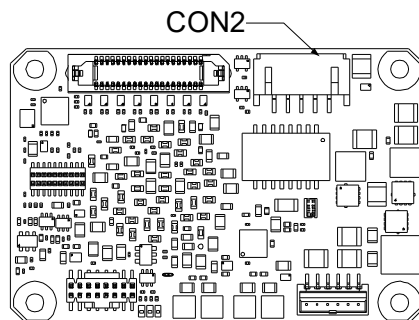

**Fig. 3-3** Location of the XETK Ethernet Interface connector (CON2)

### 3.4 Debug Interface

The XETK-S16.0 features a JTAG debugging interface connector CON3 (Samtec 16 pin). This connector can be used to attach a 3rd party debug tool (e.g. Lauterbach or PLS debugger). Contact your local support organization about connecting the XETK-S16.0 to a 3rd party debugger.

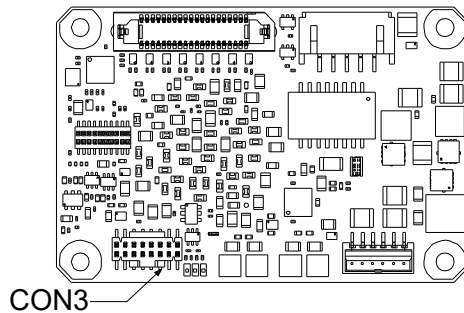

**Fig. 3-4** Location of the Debugger Interface connector CON3

When using the JTAG debug interface on the ECU board for serial ETK connection, the JTAG debug interface is not available any longer for software debugging tools. The XETK-S16.0 provides a hardware arbitration mechanism for the JTAG interface. This arbitration mechanism enables the simultaneous use of tools for debugging and ETAS tools for measurement and calibration.

### 3.5 Power Supply

The XETK-S16.0 requires a permanent power supply. It is typically powered directly from the car battery. The input voltage may vary between 6 V and 36 V. In case of higher input voltages to the XETK, additional voltage protection is required. The XETK-S16.0 will also accept voltage dips down to 3V (for additional details of low voltage operation, see ISO standard 16750).

From the input battery voltage, the XETK-S16.0 creates all necessary voltages through switching power supplies on the XETK-S16.0. The power supply of the ECU is not affected by the XETK-S16.0. An automatic switch ensures that the power supply of the XETK-S16.0 is automatically switched on and off when the XETK enters and leaves its standby (sleep) mode.

The XETK-S16.0 can be supplied with power through the six-pin connector, CON4.

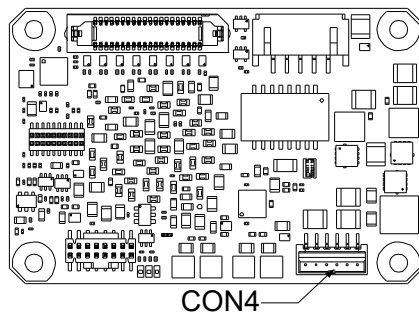

**Fig. 3-5** Location of the XETK-S16.0 Power Supply Connector CON4

### 3.6 ECU Voltage Supervisor

The ECU voltage (VDD) is monitored by the XETK to recognize whether the ECU is switched on or off. Additionally the ECU RAM standby voltage (VDDSTBY) is monitored to determine if the standby RAM content is still valid. These two signals are only used for monitoring therefore the load current is negligible.



#### NOTE

The XETK-S16.0 only allows switching between reference page and working page if there is a valid voltage at the sense pin and the working page has been initialized by the calibration and development system.

The XETK-S16.0 provides two opportunities to supply and supervise the ECU RAM standby voltage:

- The XETK-S16.0 monitors the VDDSTBY supply on board the XETK. The microcontroller's standby power supply pin must be connected to the XETK pin VDDSTBY.
- The XETK-S16.0 monitors the VSTBY pin, provided by the ECU connection. The microcontroller's standby power supply pin must be connected to the XETK pin VSTBY. The microcontroller's standby power supply may be provided by the ECU or by the XETK.

### 3.7 Status LEDs

There are three LEDs (Green, Red, Yellow) displaying the operating status of the XETK-S16.0 (Fig. 3-6 on page 20).

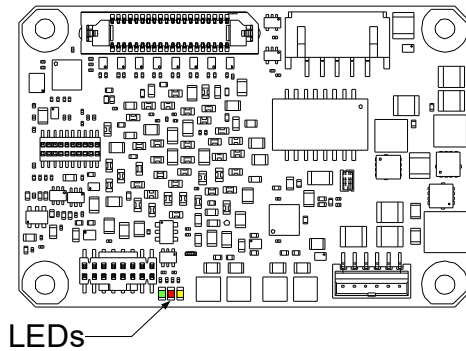

**Fig. 3-6** Status LEDs of the XETK-S16.0

LED	State	Definition
Red	On	XETK-S16.0 is supplied with power and active (i.e. the ECU is switched on or the 100 Mbit/s link to the calibration system is established)
Green	Off	Working page may be different from reference page. Calibration and development system has downloaded data since the last power failure. Switching between the Reference Page and Working Page is possible.
	On	Power supply has dropped under selected threshold: - data retention of the calibration data manager in the ECU is no longer ensured - as soon as the XETK-S16.0 switches on again, the ECU switches to the Reference Page. Green LED stays on until the calibration and development system downloads data into the calibration data memory. Otherwise switching to the Working Page is not possible.
Yellow	Flashing	Communication active
	On	100 Mbit/s link to calibration system established

### 3.8 Data Emulation and Data Measurement

The XETK-S16.0 is a serial XETK using JTAG as the primary microcontroller interface. Typical for all serial (X)ETKs, the RAM used for data emulation and data measurement is not accessible by the XETK until the microcontroller is powered up and the startup handshake is performed.

Serial XETKs use the ETAS two-page concept, consisting of both a Reference and a Working page.

The Reference Page is located in the ECU flash and cannot be modified by a simple write access. All changes to the Reference Page must be done via Flash programming.

The Working Page is located within the microcontroller's emulation RAM. The Working Page may be a portion of or the entire size of the emulation RAM. The emulation RAM used for the emulation of calibration data must not be used by the ECU software directly as general purpose RAM. It is recommended that the emulation RAM is permanently powered by the XETK or ECU. The XETK/INCA has the complete control over the RAM used as Working Page and its contents. When enabling data emulation, the XETK establishes a basic start-up configuration of the data in the Working Page by copying the corresponding data in the Flash to the emulation space.

To enable calibration, the Working Page must be activated. The process of switching from the Reference Page to the Working Page and vice versa is known as page switching.

The XETK-S16.0 supports Protocol Based page switching for all supported microcontrollers. Page switching is done in microcontroller software by switching the overlay memory on (Working Page) and off (Reference Page) using microcontroller overlay registers. The XETK-S16.0 does not directly control the microcontroller overlay registers. Instead the XETK-S16.0 and microcontroller software use a simple communication method with a shared mailbox in RAM. The XETK uses this mailbox to request and monitor page switching; the microcontroller software is responsible to service this mailbox and perform the page switches. Using an overlay modification description, also in RAM, the XETK provides the necessary information of how the overlay registers need to be modified to realize the page switch which is requested.

The XETK-S16.0 can access both the Reference Page and the Working Page, regardless of which is active from the microcontroller's point of view.

Another important restriction is that no access to the memory is possible, while the ECU is not running. To enable a cold start measurement in spite of this restriction, the cold start measurement procedure is defined to give the user the feeling of a parallel XETK.

### 3.9 XETK-S16.0 JTAG Interface

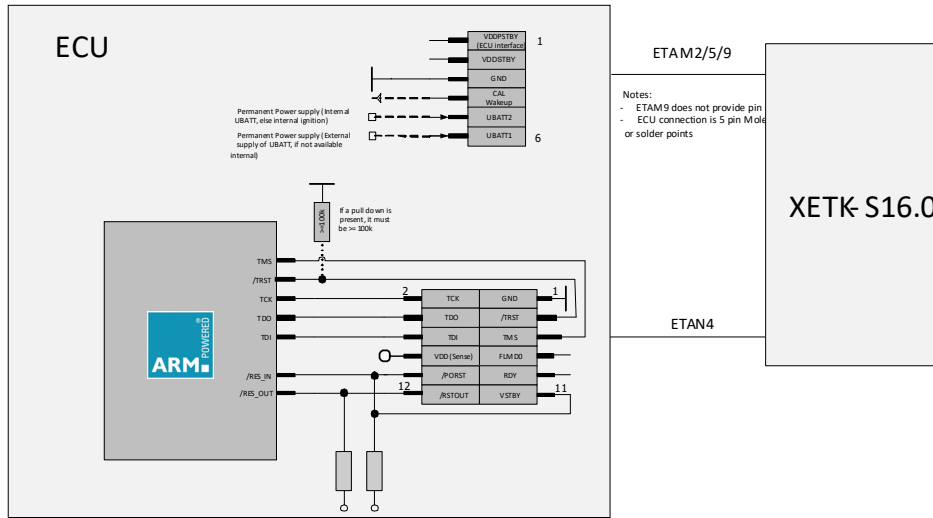

- Routing of traces from uC to 12 pin connector:
- PCB trace lengths should be as short a possible for the TMS, TRST, TCK, TDI & TDO signals
  - If signals are T to a 2nd connector, it is recommended to add zero ohm jumpers in line so the signal T can be broken
  - ETAN1 cable is 50 ohm cable, it is recommended to match the PCB impedance to the cable impedance

**Fig. 3-7** Equivalent Circuitry of the ECU JTAG Interface (ECU)

The ECU part of the JTAG XETK interface is depicted in Fig. 3-7.

The XETK-S16.0 incorporates 22 Ohm series resistors for the TMS, TCK, TDI and /TRST lines on the ECU interface. Hence, no additional termination resistors are required on the ECU for these signals.

Additional Design Recommendations:

- Debug connector should be placed as close to the microcontroller as possible
- If a pull-down resistor is present on the line /TRST, the ECU must use a value no smaller than 100k ohm as shown in Fig. 3-7 on page 22.
- PCB trace lengths should be as short as possible for the TMS, TRST, TCK, TDI & TDO signals
- If any JTAG signals are also routed to a 2nd connector (Forked/Split or T'd), It is recommended to add zero ohm jumpers in line so the signal T can be broken
- The ETAN4A cables are 50 ohm impedance for all signals, it is recommended to match the PCB impedance to the cable impedance

**NOTE**

Please consult with your local ETK support regarding connections to the XETK-S16.0 including watchdog timer disable, voltage and or reset monitoring, calibration wake-up, etc... ETAS ETK support can review adaptations to the circuit/connections between the ECU interface and the XETK-S16.0 as shown in Fig. 3-7 on page 22.

### 3.10 Trigger Modes: Overview

The XETK-S16.0 supports the following trigger modes:

- Pinless triggering
- Timer triggering

The trigger mode "Pinless Triggering" uses the microcontroller's RAM addresses for triggering. See chapter "Pinless Triggering" on page 23 for further details.

The trigger mode "Timer Triggering" uses four internal timers of the XETK for triggering. See chapter "Timer Triggering" on page 23 for further details.

### 3.11 Pinless Triggering

#### 3.11.1 Startup Handshake

Microcontroller RAM addresses are used for XETK startup handshake. During this handshake, ECU software detects the connected XETK by reading and writing to specific RAM location and performing basic initializations based on the handshake values. When these initializations are done, the handshake is finished with success acknowledgment to the XETK. Thereafter, if a success acknowledgment is received by the XETK, it starts additional initialization processes (e.g. coldstart, checksum, downloads, etc.).

After the startup handshake and measure enabled, the XETK waits for triggers from ECU software.

#### 3.11.2 XETK Trigger Generation

To generate triggers, the ECU software toggles bits of specific RAM address (next to handshake address) and each bit corresponds to an XETK hardware trigger.

The XETK periodically polls (reads) the trigger registers via JTAG. The polling rate is configurable, with 50  $\mu$ s default. The XETK then starts acquisition of appropriate measurement data based on which bits of the registers are set.

### 3.12 Timer Triggering

The trigger mode "Timer Triggering" uses four internal timers of the XETK-S16.0 for triggering. A configurable period is used for triggering.

The time intervals between trigger events are in accordance with the configured timer values. These values and their resolution have to be defined in the XETK's configuration and/or A2L file. Available settings are:

- Minimum time interval 100  $\mu$ s
- Maximum period duration 1 s
- Timer resolution 1  $\mu$ s

The timers trigger the XETK in an asynchronous manner to the microcontroller software. Variables assigned to a measurement raster using a timer trigger are acquired from their original locations in RAM via JTAG.

### 3.13 Reset

The requirement for XETK reset mechanism is to ensure that power-up and power-down behavior of ECU is clean and smooth. The XETK-S16.0 drives /PORESET low during XETK power up or upon INCA request.

The XETK-S16.0 senses the status of the /PORESET line to detect when the ECU is in reset. If configured, and the microcontroller has /RESETOUT, the XETK-S16.0 can also be used to sense the status for the ECU reset.

The XETK-S16.0 senses the switched ECU power supply, VDDP. This allows the XETK to detect when the ECU is off and forward the information to INCA. In addition, it allows the XETK to enter the power save mode when the calibration system is unplugged.

### 3.14 Pull CalWakeUp until Startup Handshake

The XETK has the ability to wake up the ECU by applying voltage to the CalWakeUp pin of the ECU connector. This allows the XETK to configure a measurement while the ECU is off.

When waking up the ECU via the CalWakeUp pin, it can be configured if the pin is driven high until the microcontroller core voltage (VDD) is high or if the pin should be driven high until the start-up handshake between ECU and XETK is complete.



## 4 Installation

This chapter contains information about the following topics:

- Mounting the XETK-S16.0 to the ECU..... 25
- Electrical Connection to the ECU..... 27
- Wiring..... 29

***NOTICE***

**Damage to the electronics due to potential equalization**

The cables' shield may be connected to the housing, the ground or the ground for the product's power supply. If there are different ground potentials in the test setup, equalizing currents can flow between the products via the cables' shield. Take account of different electric potentials in your test setup and take appropriate measures to prevent equalizing currents.

### 4.1 Mounting the XETK-S16.0 to the ECU

 **NOTE**

For all mounting methods of the XETK-S16.0 to the ECU housing, the thermal gap pad must be used when the operating temperature range of the ECU exceeds 85 °C (185 °F).

 **NOTE**

When you mount the XETK-S16.0 to the ECU, you must ensure that any screws and washers used will not penetrate the XETK printed circuit board.

#### 4.1.1 Mechanical connection of the XETK-S16.0 to the ECU Housing

To ensure proper operation of the XETK-S16.0 over the specified temperature range (refer to chapter "Environmental Conditions" on page 38), the XETK-S16.0 must be mounted to the ECU metal housing using the enclosed Gap Pad. This enables thermal dissipation of the electronic components used on the XETK-S16.0 to the ECU housing. This chapter describes an example for proper mounting of the XETK-S16.0 to the ECU housing with the included Gap Pad.

 **NOTE**

If the temperature range for the ECU application is significantly less than the specified temperature range for the XETK-S16.0 (e.g. - 40 °C to +85 °C/ - 40 °F to +185 °F), use of the gap pad and the thermal connection to the ECU housing is not mandatory.

#### Mounting Materials

For mounting the XETK-S16.0 to the ECU housing, the following parts are suggested:

- 4x screws M2.5
- XETK-S16.0
- Gap Pad, as supplied with the XETK-S16.0 or available as a spare part.
- 4x 3.0 mm height spacer, M2.5
- ECU metal housing with machined holes aligning with XETK-S16.0 hole pattern (see "Mechanical Dimensions" on page 50)
- 4x nuts M2.5

See figure "XETK-S16.0 mounting materials" on page 27.

### Placing the Gap Pad on the XETK-S16.0

1. On the Gap Pad, remove the blue colored adhesive backing. This will expose adhesive on the Gap Pad that will allow the Gap Pad to adhere to the XETK-S16.0.
2. Place the Gap Pad (adhesive side down) onto the XETK-S16.0 as depicted in the figures "XETK-S16.0 bottom side view" on page 26 and "XETK-S16.0 with properly positioned Gap Pad" on page 26.

### Devices to cover with Gap Pad

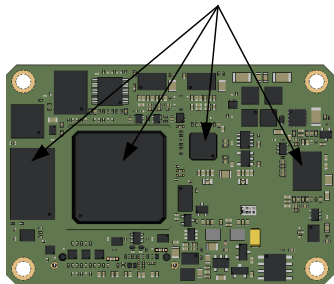

**Fig. 4-1** XETK-S16.0 bottom side view

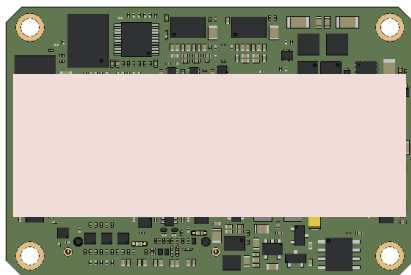

**Fig. 4-2** XETK-S16.0 with properly positioned Gap Pad

**NOTE**

To ensure good thermal transfer between the XETK-S16.0 and the ECU housing, during the installation process, always use a new Gap Pad. Re-use of the Gap Pad during a re-installation or ETK recycling is not recommended. Additional Gap Pads are available as a stand-alone item. See "Mounting Material" on page 62 for ordering information.

#### 4.1.2 Mounting the XETK-S16.0 to the ECU metal Housing

Mount the XETK-S16.0 to the ECU housing as depicted in figures "XETK-S16.0 mounting materials" on page 27 and "XETK-S16.0 mounted" on page 27.

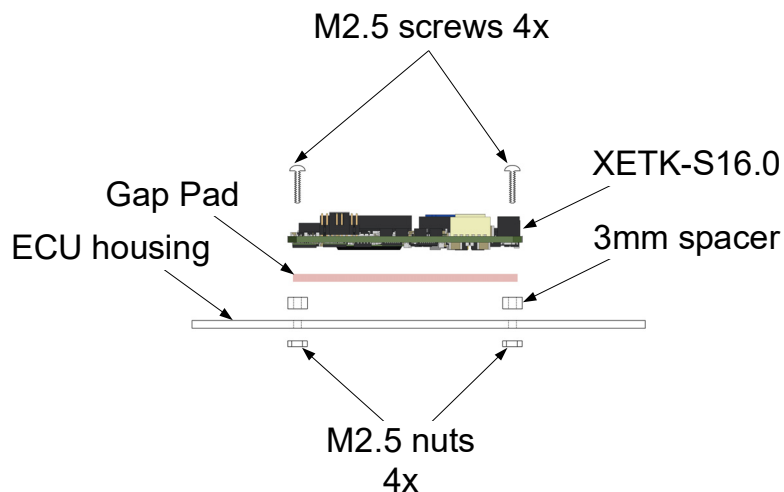

**Fig. 4-3** XETK-S16.0 mounting materials

**NOTE**

Thermal transfer from the XETK to the ECU housing!  
When you mount the XETK to the ECU, you must ensure that a constant gap of 3 mm is maintained between the XETK-S16.0 PCB and the flat surface of the ECU housing.

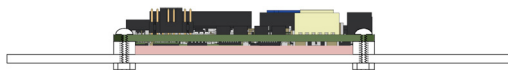

**Fig. 4-4** XETK-S16.0 mounted

## 4.2 Electrical Connection to the ECU

For connecting the XETK-S16.0 to the ECU, two XETK adapter cables are recommended:

- at CON1 adapter ETAN4A
- at CON4 adapter ETAM2 or ETAM5 or ETAM9

The adapter cables are to be ordered separately (refer chapter "Ordering Information" on page 62).

The suitable connectors Samtec-12 and Molex 6 (or solder positions for ETAM2)) (see Fig. 4-6 for additional connector details) should be populated onto the ECU PCB for adapters ETAN4A and ETAM2/ ETAM5/ ETAM9.

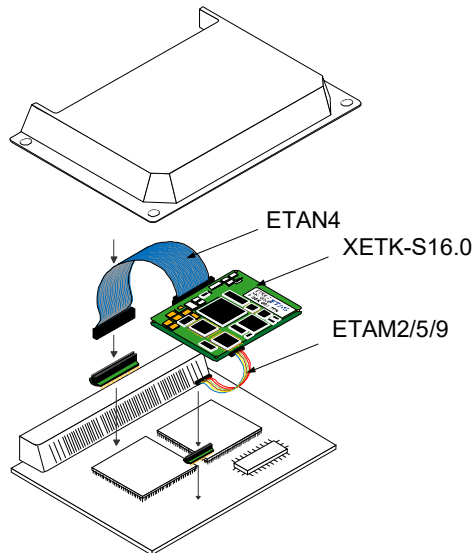

Fig. 4-5 XETK-S16.0 Connection to the ECU

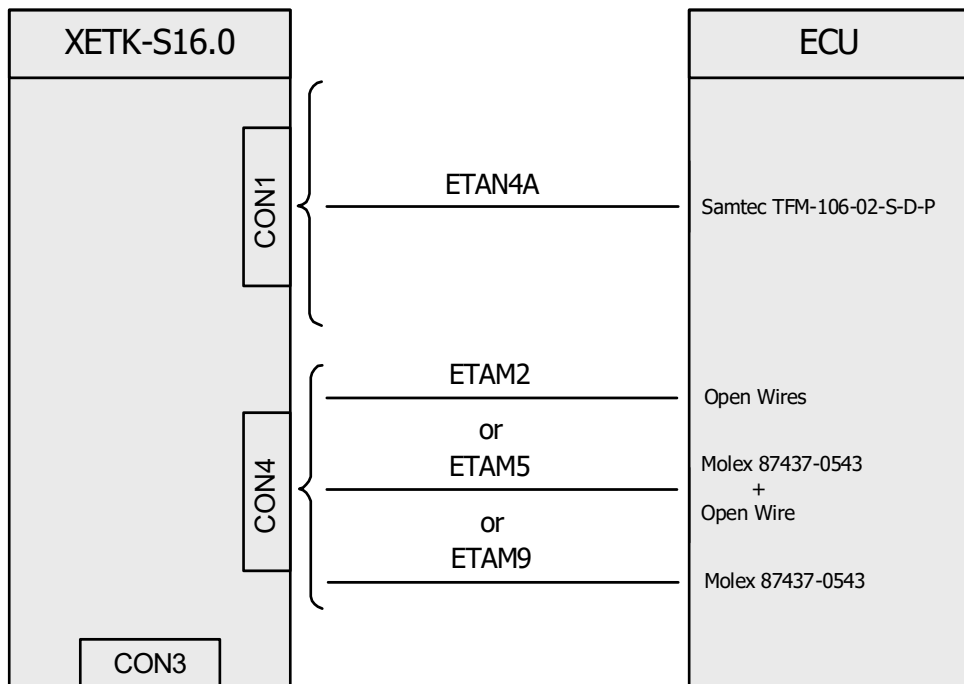
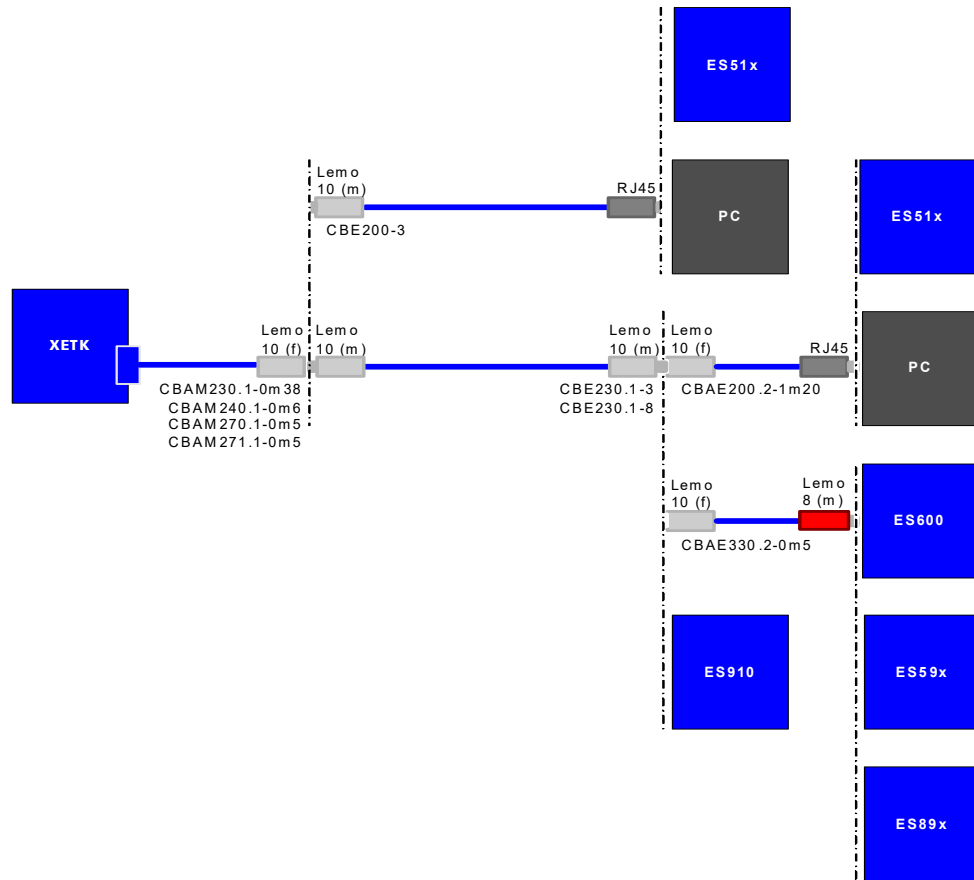

Fig. 4-6 XETK-S16.0 Connection to the ECU

### 4.3 Wiring

#### 4.3.1 XETK Ethernet Interface



**Fig. 4-7** Wiring - XETK Ethernet Interface

The XETK Ethernet interface can be directly connected to the PC. No additional ETAS module is required for the access to the ECU.

### 4.3.2 Power Supply

 **DANGER**

**Undefined vehicle behavior due to an ECU reset**

If the external power supply to the ETK is interrupted (e.g. cut, disconnected, etc.), this may lead to the ECU being reset.

- Connect the internal power supply of the ECU to the ETK in addition to the external power supply.
- If this is not possible, ensure that the external power supply to the ETK is not interrupted during operation.

 **WARNING**

**Risk to life from electric shock**

If an unsuitable power supply is used, this may generate a hazardous electrical voltage.

- Use a power supply that is permitted for the product.

The XETK-S16.0 needs a permanent power supply (refer chapter “Power Supply” on page 18). Refer to figures Fig. 4-8, Fig. 4-9, or Fig. 4-10 for recommendations on permanent power supply connection to XETK-S16.0. For the fuse details, refer to chapter “Power Supply” on page 39.

#### Permanent Power Supply inside ECU available

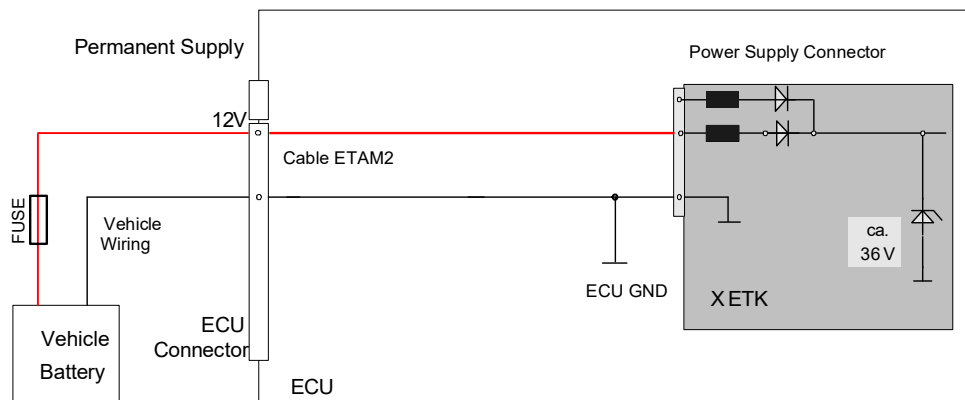

**Fig. 4-8** Permanent Power Supply inside ECU available

### Permanent Power Supply inside ECU not available

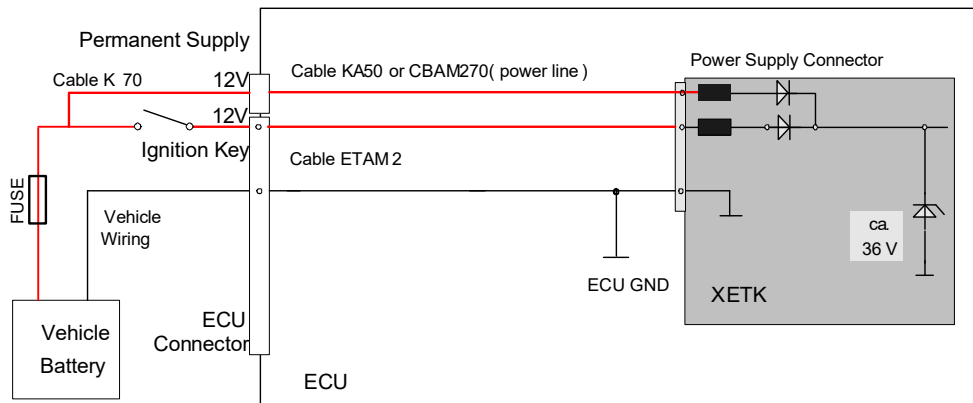

**Fig. 4-9** Permanent Power Supply inside ECU not available

### Isolated Power Supply inside ECU

The XETK-S16.0 does not require a galvanically isolated power supply. For special applications ETAS offers the isolated power supply ETP2.

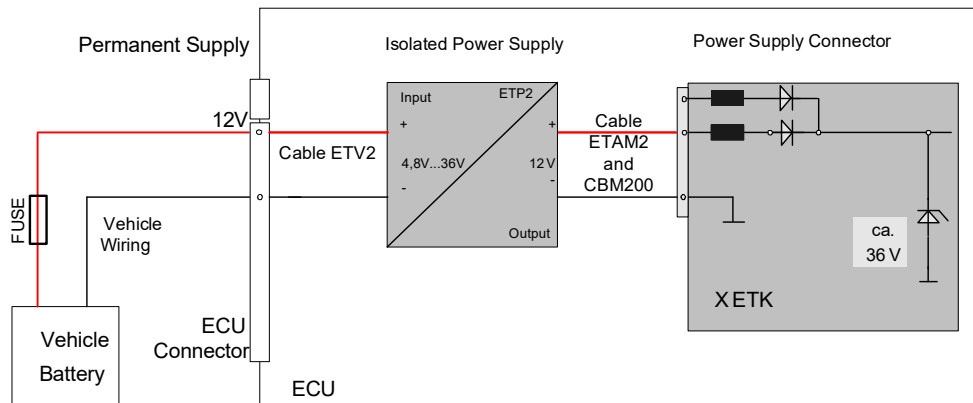

**Fig. 4-10** Isolated Power Supply inside ECU

## 5 XETK Configuration

This chapter contains information about the following topics:

- Overview ..... 32
- Configuration Parameter ..... 33

### 5.1 Overview

As already mentioned in previous chapters, some project-specific adjustments are necessary. Configuration data is stored permanently in a serial Flash.

Generating a valid configuration data set is supported by the "(X)ETK Configuration Tool" (XCT Tool). The XCT Tool contains information on all available XETKs. The user is supported through a graphical user interface.

The configuration is done in two steps:

1. Generation of the special address offset for the emulation and measurement data memory.  
The location of data areas, measured data output areas, trigger segment addresses etc. are familiar to the ECU software developer, or can be generated automatically. If an ECU description database (ASAP, ...) with the corresponding input exists, these inputs can be downloaded from this database. If necessary, a plausibility check is performed.
2. Connection of the XETK to the ECU.  
The ECU hardware developer defines the connection of the XETK to the ECU. The corresponding signals usually have to be adjusted for each microcontroller. All inputs are checked for plausibility, to make sure that a valid configuration is generated.

The "(X)ETK Configuration Tool" can create the following output:

- Direct XETK configuration
- Storage of the configuration in a data file
- The corresponding ASAP2 input

The most important outputs are the entries for the ASAP2 file. All A2L definitions necessary for configuring an XETK will be created. These are:

- Overlay Region definitions
- Memory Segment definitions
- XETK configuration features
- Raster definitions

If these parameters are entered correctly in the corresponding ECU description file, it guarantees that every time the calibration system is started, the XETK is checked for the appropriate configuration. If necessary, the XETK will be configured appropriately to the corresponding project.



## 5.2 Configuration Parameter

The XCT Tool provides support concerning hardware configuration parameters and their possible values.

The configuration parameters are described for the different (X)ETK types in the help menu of the "(X)ETK Configuration Tool".

### Starting the "XCT Tool" help

1. Start the XCT Tool.  
The main window of the XCT tool opens.
2. Select in the menu bar ? → **Contents**.  
The XCT Tool help window opens.
3. Choose **Reference to User Interface** → **(X)ETK Hardware Configuration Parameters**.
4. Choose the topic **XETK-S16.0**.  
The topic **XETK-S16.0** contains information about the XETK-S16.0 hardware configuration parameters and their possible values.

## 6 Troubleshooting

### 6.1 Problems and Solutions

#### 6.1.1 No communication between the ECU and ETK

**Cause:** No permanent powersupply at the XETK-S16.0.

It is possible, that if ECU and ETK are switched-on simultaneously, no communication between the ECU and ETK can be established.

**Workaround:** Trigger an ECU reset by application tool.



#### NOTE

The XETK-S16.0 requires a permanent power supply. It is typically powered directly from the car battery. Refer to chapter "Power Supply" on page 30.

## 7 Technical Data

This chapter contains information about the following topics:

- System Requirements ..... 35
- Data Emulation and Measurement Memory ..... 37
- Configuration ..... 37
- XETK Ethernet Interface ..... 38
- Environmental Conditions ..... 38
- Power Supply ..... 39
- Test Characteristics ..... 40
- JTAG Timing Characteristics ..... 40
- Electrical Characteristics ..... 43
- Pin Assignment ..... 48
- Mechanical Dimensions ..... 50

### 7.1 System Requirements

#### 7.1.1 ETAS Compatible Hardware

ES51x, ES592, ES593-D, ES595, ES600, ES88x, ES89x, ES910 (INCA)

#### 7.1.2 PC with one Ethernet Interface

A PC with one open Ethernet interface (1 Gbit/s or 100 Mbit/s, full duplex) with RJ45 connection is required. Ethernet interfaces that are implemented with an additional network card in the PC must feature a 32-bit data bus.



#### NOTE

Half Duplex mode and Half Duplex Ethernet interfaces are not supported.

#### Requirement to ensure successful Initialization of the Module



#### NOTE

It is imperative to disable the function which automatically switches to power-saving mode on your PC network adapter when there is no data traffic on the Ethernet interface!

#### To deactivate the power saving mode

Choose in Windows System Control Center / Device Manager / Network Adapter the used network adapter by double-click. Deactivate the "Allow the computer to turn off this device to save power" option in the "Power Management" register. Confirm your configuration.

The manufacturers of network adapter have different names for this function.

Example:

- "Link down Power saving"
- "Allow the computer to turn off this device to save power"

### 7.1.3 XETK-S16.0 Software Support

You need following software versions to support the XETK-S16.0:

#### 7.1.3.1 Use case: Measurement & Calibration, ECU Flash Programming

Microcontroller	INCA	INCA-MCE	HSP	ETK Tools
NXP S32Vxxx	V7.2.14	V2.0	V11.14.0	V4.1.15
NXP S32K14x	V7.3.1	V2.0	V12.1	V4.2.1
NXP S32Gxxx	V7.3.4	V2.0	V12.4	V4.2.4
NXP S32K3xx	V7.3.3	V2.0	V12.3	V4.2.3
NXP S32Z27x	V7.4.4	V2.0	V13.4	V4.3.4
NXP S32NZ5x	V7.4.7	V2.0	V13.7	V4.3.7
Cypress S6J3xxx	V7.2.14	V2.0	V11.14.0	V4.1.15
Cypress CYT2Bx	V7.2.14	V2.0	V11.14.0	V4.1.15
Cypress CYT4Bx	V7.2.14	V2.0	V11.14.0	V4.1.15
TI AM263x	V7.4.3	V2.0	V13.3	V4.3.3
Thinktech TTA8	V7.4.4	V2.0	V13.4	V4.3.4

#### 7.1.3.2 Use case: Rapid Prototyping

Item	Description
Supported microcontroller	All microcontrollers listed in chapter 7.1.3.1 on page 36
ASCET-RP	V6.4
INTECRIO	V4.6
Supported Bypass methods	Service Based Bypass SBB V2.1



#### NOTE

The XETK-S16.0 supports the bypass procedure with DISTAB17. Classical Hook Based Bypass (HBB) method is not supported. This can be realized via "Hooked Service Points" (with the help of a SBB Service Point and DISTAB17).

## 7.2 Data Emulation and Measurement Memory

### 7.2.1 Data Emulation Memory and Microcontroller Support

The XETK-S16.0 can use any available RAM to emulate data in internal flash. The following table lists the supported microcontrollers, the available emulation RAM, and states if the emulation RAM is capable of being powered using a standby supply.

Microcontroller	Available emulation RAM (Mbytes)	Standby powered
NXP S32Vxxx	ECU defined (external RAM or internal RAM)	Yes - External No - Internal
NXP S32K14x	Internal RAM	No
NXP S32Gxxx	Internal RAM	No
NXP S32K3xx	Internal RAM	No
NXP S32Z27x	Internal RAM	No
NXP S32NZ5x	ECU defined	No
Cypress S6J3xxx	Internal RAM	No
Cypress CYT2Bx	Internal RAM	No
Cypress CYT4Bx	Internal RAM	No
TI AM263x	Internal RAM	No
Thinktech TTA8	Internal RAM	No

### 7.2.2 Measurement Data Memory

Item	Characteristics
Location	Typically located within the emulation memory when using DISTAB hooks. Measurement data memory can be located in internal RAM if the entire emulation RAM is needed for calibration.

## 7.3 Configuration

Item	Characteristics
Configuration	Project-specific configuration for - different microcontrollers or - memory configurations stored in EEPROM
Update	Logic devices updated using HSP software

## 7.4 XETK Ethernet Interface

Item	Characteristics
Connection	- 100 Mbit/s Ethernet, Full Duplex - PC Card 32 bit
Protocol	XCP on TCP/IP or UDP/IP
IP address	Dynamic (standard, for INCA) or static (e.g. for Rapid Prototyping) by using the XETK Configuration Tool (default IP address: 192.168.40.16)
Cable length	max. 30 m / 100 ft
Ethernet Interface	DC decoupling Max. Isolation Voltage 60 V DC, according IEC 61010-1 "Limit values for accessible parts" in normal, dry condition.



### NOTE

To ensure successful initialization of the network card of your PC, refer to chapter 7.1.2 on page 35

## 7.5 Environmental Conditions

Item	Characteristics
Operating temperature range	- 40 °C to +110 °C / - 40 °F to +230 °F
Storage temperature range (without packaging)	0 °C to +50 °C / +32 °F to +122 °F
Max. relative humidity (non-condensing)	95%
Max. altitude	5000 m / 16400 ft
Degree of contamination (IEC 60664-1, IEC 61010-1)	2
Protection rating (when closed)	Determined by installation in ECU
Overvoltage category (AC mains supply)	II

## 7.6 Power Supply

Parameter	Symbol	Condition	Min	Typ	Max	Unit
Permanent power supply (car battery)	$U_{\text{Batt}}$	Vehicle usage <sup>1)</sup>	6.0	12	36	V
[all values +/-0%]						
Standby current	$I_{\text{STBY}}$	$U_{\text{Batt}} = 12\text{ V}$ ; ECU off; $I = 0\text{ mA}$ at pin VDDSTBY; $I = 0\text{ mA}$ at pin VDDPSTBY; $T = 20\text{ °C}$		70	95	mA
Operating current	$I_{\text{Batt}}$	$U_{\text{Batt}} = 12\text{ V}$ ; $I = 0\text{ mA}$ at pin VDDSTBY; $I = 0\text{ mA}$ at pin VDDPSTBY; $T = 20\text{ °C}$		165	215	mA
Operating current	$I_{\text{Batt}}$	$U_{\text{Batt}} = 12\text{ V}$ ; $I = 500\text{ mA}$ at pin VDDSTBY; $I = 80\text{ mA}$ at pin VDDPSTBY; $T = 20\text{ °C}$		215	315	mA
Power dissipation	$P_{\text{Batt}}$	$U_{\text{Batt}} = 12\text{ V}$ ; $I = 0\text{ mA}$ at pin VDDSTBY; $I = 0\text{ mA}$ at pin VDDPSTBY; $T = 20\text{ °C}$		1.75		W
Power dissipation	$P_{\text{Batt}}$	$U_{\text{Batt}} = 12\text{ V}$ ; $I = 500\text{ mA}$ at pin VDDSTBY; $I = 80\text{ mA}$ at pin VDDPSTBY; $T = 20\text{ °C}$		2.78		W
Fuse in the ETK Ubatt supply line. Only required if the power supply or ECU is not protected accordingly.				MINI, 2 A 58 V DC (Littelfuse 0997002.WXN)		

<sup>1)</sup> The XETK-S16.0 implements reverse voltage protection in the same range and may be used only with central load dump protection.  
24 V vehicles require  $U_{\text{Batt}}$  disturbing pulse reduction to 12 V vehicle system.  
12 V vehicles don't require special disturbing pulse reductions.

**NOTE**

The XETK-S16.0 will accept permanent power supply voltage dips (for additional details of 3 V low voltage operation, see ISO standard 16750).

## 7.7 Test Characteristics

Parameter	Symbol	Condition	Min	Typ	Max	Unit
Reset delay 1 <sup>1)</sup>	$t_{Reset1}$	$U_{Batt} = 12\text{ V}$ $VDDP = 0\text{ V} \uparrow 1.8\text{V}/3.3\text{V}/5.0\text{V}$ without transferring FPGA	26		50	ms
Reset delay 2 <sup>2)</sup>	$t_{Reset2}$	$U_{Batt} = 0\text{ V} \uparrow 12\text{ V}$ transfer FPGA	100		300	ms

<sup>1)</sup> Delay of ECU reset through the XETK without transferring the FPGA ( $U_{Batt}$  present, VDDP will be switched on)

<sup>2)</sup> max. delay of ECU reset through the XETK ( $U_{Batt}$  and VDDP will be switched on)

## 7.8 JTAG Timing Characteristics

The following diagrams show the timings the XETK-S16.0 can process.

**i** NOTE

JTAG timing parameters in this chapter refer to the JTAG interface (CON1) of the XETK-S16.0. The JTAG wiring to the ECU (ETANx) must be taken into account additionally.

All timings are measured at a reference level of 1.5 V. Output signals are measured with 20 pF to ground and 50  $\Omega$  to 1.5 V.

### 7.8.1 JTAG Timing Diagram

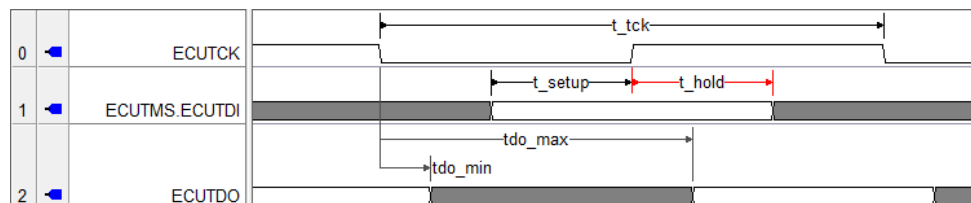



## 7.8.2 JTAG Timing Parameters

### 7.8.2.1 10 or 20 MHz JTAG selected

Parameter	Symbol	Value [ns]	Comment
JTAG Clock Period (ETK --> Target)	$t_{tck}$	100	10 MHz JTAG Clock Frequency
		50	20 MHz JTAG Clock Frequency
TMS/TDI Set-Up Time (ETK --> Target)	$t_{setup}$	5 (min.)	
TMS/TDI Hold Time (ETK --> Target)	$t_{hold}$	25 (min.)	
TDO clock-to-out time (Target --> ETK)	$t_{do\_min}$	0 (min.)	
		$t_{do\_max}$	25 (max)

### 7.8.2.2 30 MHz JTAG selected

Parameter	Symbol	Value [ns]	Comment
JTAG Clock Period (ETK --> Target)	$t_{tck}$	33.3	30 MHz JTAG Clock Frequency
TMS/TDI Set-Up Time (ETK --> Target)	$t_{setup}$	5 (min.)	
TMS/TDI Hold Time (ETK --> Target)	$t_{hold}$	5 (min.)	
TDO clock-to-out time (Target --> ETK)	$t_{do\_min}$	1 (min.)	
		$t_{do\_max}$	22 (max)

### 7.8.2.3 40 MHz JTAG selected

Parameter	Symbol	Value [ns]	Comment
JTAG Clock Period (ETK --> Target)	$t_{tck}$	25	40 MHz JTAG Clock Frequency
TMS/TDI Set-Up Time (ETK --> Target)	$t_{setup}$	5 (min.)	
TMS/TDI Hold Time (ETK --> Target)	$t_{hold}$	5 (min.)	
TDO clock-to-out time (Target --> ETK)	$t_{do\_min}$	1 (min.)	
		$t_{do\_max}$	17.5 (max)

### 7.8.3 Debugger Arbitration Timing Diagram

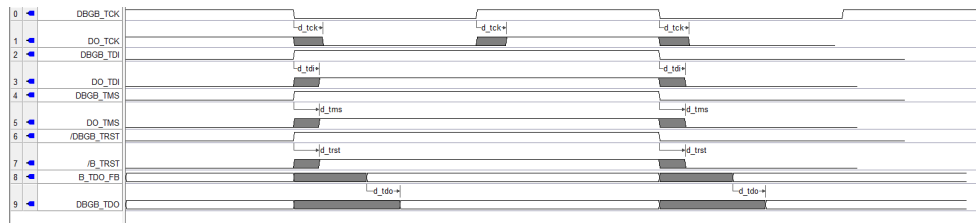

### 7.8.4 Debugger Arbitration Timing Parameters

Parameter	Value [ns]
d_tck (Debugger --> XETK)	15
d_tdi (Debugger --> XETK)	15
d_tms (Debugger --> XETK)	15
d_trst (Debugger --> XETK)	15
d_tdo (XETK --> Debugger)	20

## 7.9 Electrical Characteristics

### 7.9.1 ECU Interface Characteristics

Parameter	Symbol	Condition <sup>1)</sup>	Min	Typ	Max	Unit
CalWakeup Output Voltage	CALWAKEUP	$U_{Batt} = 6.6 - 32 \text{ V};$ load 0 - 50 mA	$U_{Batt} - 1 \text{ V}$		$U_{Batt}$	V
ECU Power Supply Supervision Voltage (1.8 V selected)	VDD	VDD ↑	1.69	1.70	1.72	V
		VDD ↓	1.53	1.56	1.58	V
	$I_{VDD}$	VDD = 1.8 V			120	μA
ECU Power Supply Supervision Voltage (3.3 V selected)	VDD	VDD ↑	2.55	2.58	2.60	V
		VDD ↓	2.41	2.43	2.45	V
	$I_{VDD}$	VDD = 3.3 V			200	μA
ECU Power Supply Supervision Voltage (5.0 V selected)	VDD	VDD ↑	4.02	4.06	4.09	V
		VDD ↓	3.88	3.91	3.94	V
	$I_{VDD}$	VDD = 5.0 V			300	μA
ECU Standby RAM Supervision Voltage (1.25 V selected)	VSTBY (Sense)	VSTBY ↑	1.13	1.14	1.15	V
		VSTBY ↓	1.11	1.12	1.13	V
	$I_{VSTBY}$	VSTBY = 1.25 V			73	μA
ECU Standby RAM Output Voltage (1.09V) <sup>2)</sup>	VDDSBRAM	max. 500 mA load	1.03	1.09	1.14	V
ECU Standby RAM Output Voltage (1.25V) <sup>2)</sup>	VDDSBRAM	max. 500 mA load	1.20	1.25	1.29	V
Power to supply ECU Interface (optional)	VDDPSBRAM	max. 80 mA load	3.20	3.30	3.40	V

<sup>1)</sup>: VDDP ↑: ECU Power Supply off → ECU Power Supply on; VDDP ↓: ECU Power Supply on → ECU Power Supply off

VDDSBRAM ↑: ECU Standby RAM Power off → ECU Standby RAM Power on

VDDSBRAM ↓: ECU Standby RAM Power on → ECU Standby RAM Power off

<sup>2)</sup>: Current drawn from XETK VDDSBRAM supply must not exceed 500 mA

## 7.9.2 ECU Interface Connector CON1 (5.0 V Interface selected)

Signal	Pin Type	V <sub>OL</sub> (max) [V]	V <sub>OH</sub> (min) [V]	V <sub>OH</sub> (max) [V]	V <sub>IL</sub> (max) [V]	V <sub>IH</sub> (min) [V]	V <sub>IH</sub> (max) [V]	Leakage current [μA]	Add. Load by XETK (typ) [pF] <sup>1)</sup>
TDI	O	0.7	3.8	5.2	-	-	-	+/-10	8
/TRST	O	0.7	3.8	5.2	-	-	-	+/-10	8
TMS	O	0.7	3.8	5.2	-	-	-	+1120/+820 <sup>3)</sup>	8
TCK	O	0.7	3.8	5.2	-	-	-	+1135/+840	12
TDO	I	-	-	-	0.8	2	6.5	+/-30	12
/PORST	XIOD <sup>2)</sup>	0.7	-	-	0.8	2	6.5	+25/-20	16
/RESETOUT	I	0.7	-	-	0.8	2	6.5	+25/-20	16
/RDY	I	-	-	-	0.8	2	6.5	+/-13	12
WDGDIS	XO	0.7	3.8	5.2	-	-	-	+/-10	20

Pin Type: I: Input, X: Tristate, O: Output, OD: Open Drain

<sup>1)</sup> Adapter cable and Samtec connector not considered; PCB 1 pF/cm

<sup>2)</sup> Open Drain FET; I<sub>Dmax</sub> = 0.2 A

<sup>3)</sup> +5200/+3830 for HW state C012

## 7.9.3 ECU Interface Connector CON1 (3.3 V Interface selected)

Signal	Pin Type	V <sub>OL</sub> (max) [V]	V <sub>OH</sub> (min) [V]	V <sub>OH</sub> (max) [V]	V <sub>IL</sub> (max) [V]	V <sub>IH</sub> (min) [V]	V <sub>IH</sub> (max) [V]	Leakage current [μA]	Add. Load by XETK (typ) [pF] <sup>1)</sup>
TDI	O	0.55	2.4	3.45	-	-	-	+/-10	8
/TRST	O	0.55	2.4	3.45	-	-	-	+/-10	8
TMS	O	0.55	2.4	3.45	-	-	-	+750/+530 <sup>3)</sup>	8
TCK	O	0.55	2.4	3.45	-	-	-	+704/+411	12
TDO	I	-	-	-	0.8	2	6.5	+/-30	12
/PORST	XIOD <sup>2)</sup>	0.7	-	-	0.8	2	6.5	+25/-20	16
/RESETOUT	I	0.7	-	-	0.8	2	6.5	+25/-20	16
/RDY	I	-	-	-	0.8	2	6.5	+/-13	12
WDGDIS	XO	0.55	2.4	3.45	-	-	-	+/-13	20

Pin Type: I: Input, X: Tristate, O: Output, OD: Open Drain

<sup>1)</sup> Adapter cable and Samtec connector not considered; PCB 1 pF/cm

<sup>2)</sup> Open Drain FET; I<sub>Dmax</sub> = 0.2 A

<sup>3)</sup> +3460/+2010 for HW state C012

## 7.9.4 ECU Interface Connector CON1 (1.8 V Interface selected)

Signal	Pin Type	V <sub>OL</sub> (max) [V]	V <sub>OH</sub> (min) [V]	V <sub>OH</sub> (max) [V]	V <sub>IL</sub> (max) [V]	V <sub>IH</sub> (min) [V]	V <sub>IH</sub> (max) [V]	Leakage current [μA]	Add. Load by XETK (typ) [pF] <sup>1)</sup>
TDI	O	0.45	1.2	1.9	-	-	-	+/-10	8
/TRST	O	0.45	1.2	1.9	-	-	-	+/-10	8
TMS	O	0.45	1.2	1.9	-	-	-	+420/+280	8
TCK	O	0.45	1.2	1.9	-	-	-	+440/+290	12
TDO	I	-	-	-	-	-	-	+/-30	12
/PORST	XIOD <sup>2)</sup>	0.7	-	-	0.63	1.17	6.5	+25/-20	16
/RESETOUT	I	0.7	-	-	0.63	1.17	6.5	+25/-20	16
/RDY	I	-	-	-	0.63	1.17	6.5	+/-13	12
WDGDIS	XO	0.45	1.2	1.9	-	-	-	+/-13	20

Pin Type: I: Input, X: Tristate, O: Output, OD: Open Drain

<sup>1)</sup> Adapter cable and Samtec connector not considered; PCB 1 pF/cm

<sup>2)</sup> Open Drain FET; I<sub>Dmax</sub> = 0.2 A

## 7.9.5 Debugger Interface Connector CON3

Signal	Pin Type	$V_{OL}$ (max) [V]	$V_{OH}$ (min) [V]	$V_{OH}$ (max) [V]	$V_{IL}$ (max) [V]	$V_{IH}$ (min) [V]	$V_{IH}$ (max) [V]	Additional Load by XETK (typ) [pF] <sup>1)</sup>
TDI	I	-	-	-	0.8	2	6.5	12
/TRST	I	-	-	-	0.8	2	6.5	12
TMS	I	-	-	-	0.8	2	6.5	17
TCK	I	-	-	-	0.8	2	6.5	12
TDO	O	0.7	2.4	3.45	-	-	-	62 <sup>3)</sup>
/PORST	connected to /PORST on ECU connector (pass-thru signal)							
VREF	O	0.7	2.4	3.45	-	-	-	12
/WDGDIS	I	-	-	-	0.8	2	6.5	12
/RDY	O	0.7	2.0	2.5	-	-	-	12
FLMDO	I	-	-	-	0.8	2	6.5	12
/BREQ	I	-	-	-	0.8	2	6.5	12
/BGRANT	O	0.7	2.4	3.45	-	-	-	12
/RESETOUT	connected to /RESETOUT on ECU connector (pass-thru signal)							

Pin Type: I: Input, X: Tristate, O: Output, OD: Open Drain

<sup>1)</sup> Adapter cable and Samtec connector not considered; PCB 1 pF/cm

<sup>2)</sup> Open Drain FET;  $I_{Dmax} = 0.2$  A

<sup>3)</sup> 17pF for hardware state C012

## 7.10 Pin Assignment

### 7.10.1 ECU Interface Connector CON1 (XETK-S16.0 Side)

Pin	Signal	Direction	Comment
1	TX0_P		Not used on XETK-S16.0
2	VDD (Sense)	In	Sense for Switched power supply of ECU (ignition)
3	TX0_N		Not used on XETK-S16.0
4	TCK	Out	JTAG Clock signal
5	GND		Signal Ground
6	GND		Signal Ground
7	TX1_P		Not used on XETK-S16.0
8	TMS	Out	JTAG Mode Select signal
9	TX1_N		Not used on XETK-S16.0
10	TDO	In	JTAG Data Out signal
11	GND		Signal Ground
12	GND		Signal Ground
13	TX2_P		Not used on XETK-S16.0
14	TDI	Out	JTAG Data In signal
15	TX2_N		Not used on XETK-S16.0
16	/RDY		Not used on XETK-S16.0
17	GND		Signal Ground
18	/EVTO	In	Debugger event signal (currently unused)
19	TX3_P		Not used on XETK-S16.0
20	/TRST	Out	JTAG Reset signal
21	TX3_N		Not used on XETK-S16.0
22	RSVD1		Not used on XETK-S16.0
23	GND		Signal Ground
24	CABLE_RST_CNTL		Not used on XETK-S16.0
25	ClockN		Not used on XETK-S16.0
26	ETK_DETECT		
27	ClockP		Not used on XETK-S16.0
28	/PORESET	BiDir	ECU Reset signal (open drain) for Reset assertion and supervision
29	GND		Signal Ground
30	/RESETOUT		ECU Internal Reset Status (sense)
31	AUDCLK		Not used on XETK-S16.0
32	VSTBY (Sense)		Sense the supply of the standby (WP) RAM
33	AURORA_RST		Not used on XETK-S16.0
34	AUDDATA0		Not used on XETK-S16.0
35	AUDRESET		Not used on XETK-S16.0
36	AUDDATA1		Not used on XETK-S16.0
37	WDGDIS		Watchdog disable signal



Pin	Signal	Direction	Comment
38	AUDDATA2		Not used on XETK-S16.0
39	AUDSYNC		Not used on XETK-S16.0
40	AUDDATA3		Not used on XETK-S16.0

### 7.10.2 Interface and Power Supply Connector CON4

Pin	Signal	Direction	Comment
1	VDDPSTBY	Out	Permanent power to supply ECU Interface (3.3V)
2	VDDSTBY	Out	Permanent power to supply ECU EMU-RAM <sup>2)</sup>
3	GND	-	Power Ground
4	CALWakeUp	Out	Wakeup functionality (12 V output) <sup>1)</sup>
5	UBATT2	In	Vehicle Battery
6	UBATT1	In	Vehicle Battery

<sup>1)</sup> if not implemented, do not connect

<sup>2)</sup> XETK can be configured to monitor its supply of VDDSTBY; voltage is sensed on board XETK.

### 7.10.3 Debugger Interface Connector CON3

Pin	Signal	Direction	Comment
1	TMS	In	JTAG Signal
2	VREF	Out	Target supply for sensing
3	TDO	Out	JTAG Signal
4	GND		Signal Ground
5	/WDGDIS	In	Watchdog disable signal
6	GND		Signal Ground
7	TDI	In	Debugger event signal (currently unused)
8	/PORST	BiDir	ECU Reset signal (open drain) for Reset assertion and supervision
9	/TRST	In	JTAG Signal
10	/RDY	Out	Not used on XETK-S16.0
11	TCK	In	JTAG Signal
12	GND		Signal Ground
13	FLMD0	In	Not used on XETK-S16.0
14	/BREQ	In	Bus Request to XETK
15	/BGRANT	Out	Bus Grant from XETK
16	/RESETOUT	Out	ECU Reset signal for supervision

### 7.11 Mechanical Dimensions

The reference measure for all drawings is millimeters

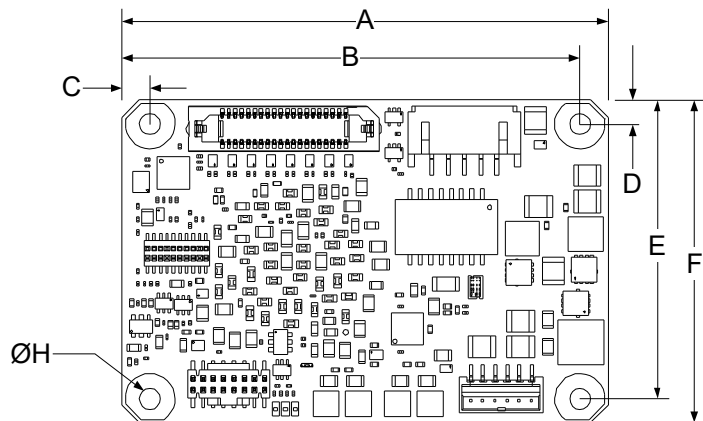

Fig. 7-1 XETK-S16.0 Dimensions - Top View

Item	Dimension [mm]	Tolerance [mm]	Dimension [in]	Tolerance [in]
A	60.00	+/- 0.20	2.362	+/- 0.008
B	56.50	+/- 0.20	2.224	+/- 0.008
C	3.50	+/- 0.10	0.138	+/- 0.004
D	3.00	+/- 0.10	0.118	+/- 0.004
E	37.00	+/- 0.20	1.457	+/- 0.008
F	40.00	+/- 0.20	1.575	+/- 0.008
H	2.50	+/- 0.20	0.098	+/- 0.008

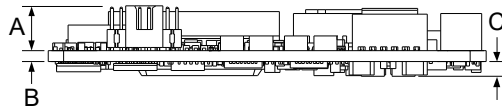

Fig. 7-2 XETK-S16.0 Dimensions - Side View

Item	Dimension [mm]	Tolerance [mm]	Dimension [in]	Tolerance [in]
A	6.121	+/- 0.20	0.241	+/- 0.008
B	1.57	+/- 0.16	0.062	+/- 0.006
C	2.0	+/- 0.10	0.079	+/- 0.004

## 8 Cables and Accessories

This chapter contains information about the following topics:

- ECU Adapter Cable..... 51
- Combined Interface and Power Supply Cable..... 53
- PC Interface Cable ..... 54
- ETAS Module Interface Adapter Cable..... 55
- Power Supply Cables..... 56
- ECU Interface Adapters ..... 58
- Water proof Case ETKS\_C3 ..... 61

### 8.1 ECU Adapter Cable

#### 8.1.1 CBAM230 Adapter Cable

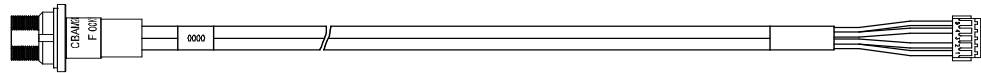
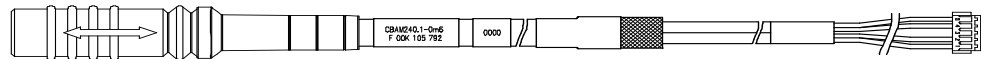

**Fig. 8-1** CBAM230 Adapter Cable

XETK ECU Adapter Cable, 100 Mbit/s, suitable for ECU flush mounting (M12), 0.38 m length, shield connected to socket. Usable for ECUs with shielded housing.

Product	Length
CBAM230-0m38	0.38 m

#### 8.1.2 CBAM240 Adapter Cable



**Fig. 8-2** CBAM240 Adapter Cable

XETK ECU Adapter Cable, 100 Mbit/s, shield connected to ECU-Housing (lead-through diameter for cable: 10 mm), 0.6 m length, shield bare for cable gland, isolated to the XETK. Usable for ECUs with shielded housing.



#### NOTE

The hardware for mounting ECU adapter cables is not included in the cable delivery, they need to be ordered separately. For detailed information on mounting accessories contact ETAS technical support.

Product	Length
CBAM240-0m6	0.6 m

### 8.1.3 CBAM271 Adapter Cable

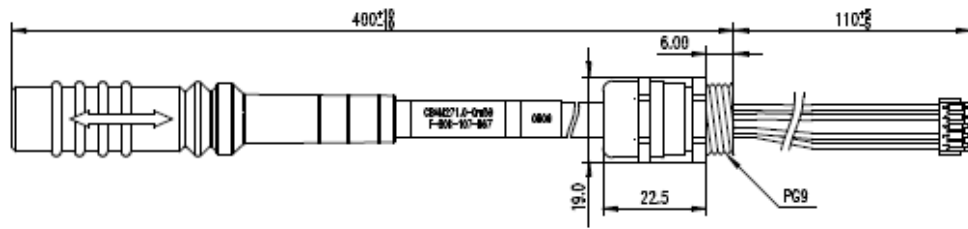

**Fig. 8-3** CBAM271 Adapter Cable

XETK ECU Adapter Cable, 100 Mbit/s, pre-assembled into PG9 screwing, shield on ECU- housing, Lemo 1B PHE - JST PHR (10fc-5fc), 0.5 m length. Fits for ETKS\_C3 case.



**NOTE**

For mounting the cable, cut a PG9 thread into the ECU housing. For thin walled housings use a nut SM-PE 9. Available from Lapp, Order number: 52103210.

Product	Length
CBAM271-0m5	0.5 m

## 8.2 Combined Interface and Power Supply Cable

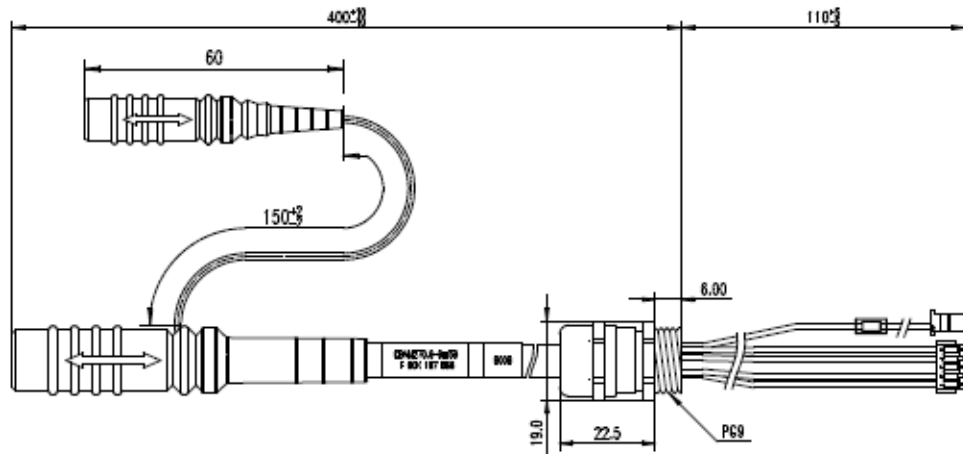

**Fig. 8-4** CBAM270 Cable (0.5 m length)

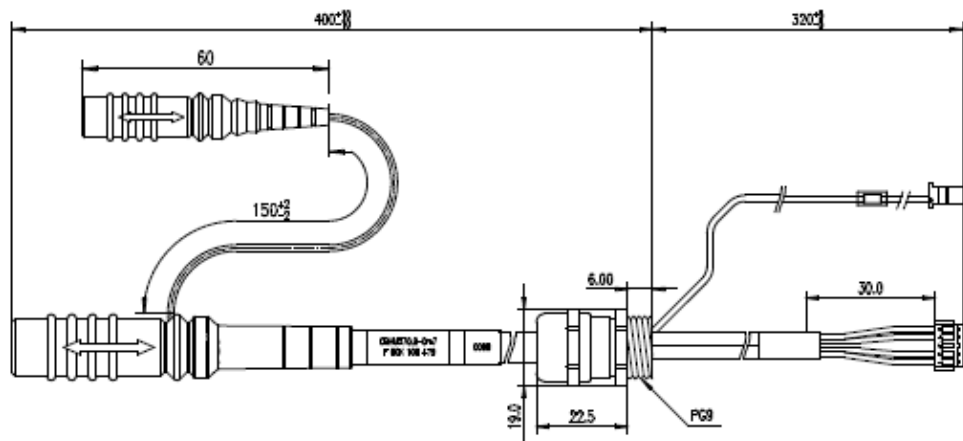

**Fig. 8-5** CBAM270 Cable (0.7 m length)

XETK ECU Adapter and Power Supply Cable, pre-assembled into PG9 screwing, shield on ECU-Housing, Lemo 1B PHE - JST PHR (10fc-5fc) / Lemo 0B PHG - JST PAP (2fc-2fc), 0.5 m and 0.7 m length.

**i** NOTE

For using the cable with an ETK with solder pad, cut the plug and solder the wire direct to the solder pad.

**i** NOTE

It is recommended for safety reasons to connect the external permanent voltage and the switched voltage inside the ECU!

**i** NOTE

For mounting the cable, cut a PG9 thread into the ECU housing. For thin walled housings use a nut SM-PE 9. Available from Lapp, Order number: 52103210.

Product	Length
CBAM270-0m5	0.5 m
CBAM270-0m7	0.7 m

### 8.3 PC Interface Cable

#### 8.3.1 CBE200 Cable



**Fig. 8-6** CBE200 Cable

Product	Length
CBE200-3	3 m
CBE200-8	8 m

#### 8.3.2 CBAE200 Adapter Cable

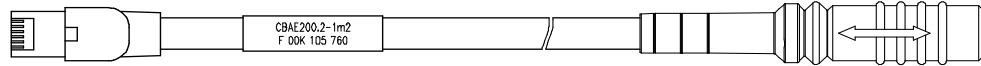

**Fig. 8-7** CBAE200 Adapter Cable

Cable adapter to connect CBE230 cable to the PC over an RJ45 connector. The CBAE200-1m2 supports Gigabit Ethernet.

Product	Length
CBAE200-1m2	1.20 m

## 8.4 ETAS Module Interface Adapter Cable

### 8.4.1 CBE230 Cable

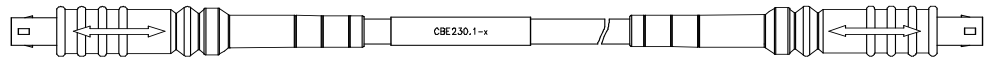
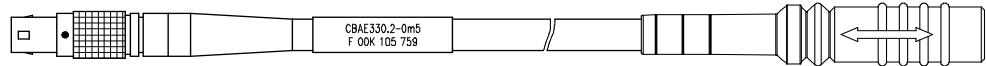

**Fig. 8-8** CBE230 Cable

Gigabit Ethernet connection cable for ETAS devices. IP67 rated Lemo connectors on both sides. Gigabit Ethernet cable with power supply.

Product	Length
CBE230-3	3 m
CBE230-8	8 m

### 8.4.2 CBAE330 Adapter Cable



**Fig. 8-9** CBAE330 Adapter Cable

Gigabit to 100 Mbit/s Ethernet Adapter for connection of CBE230 to ES600.

Cable adapter to connect CBE230 cable with the ES600. Power supply over the CBAE330 cable adapter is not supported.

Product	Length
CBAE330-0m5	0.5 m

## 8.5 Power Supply Cables

### 8.5.1 ETV5 Cable

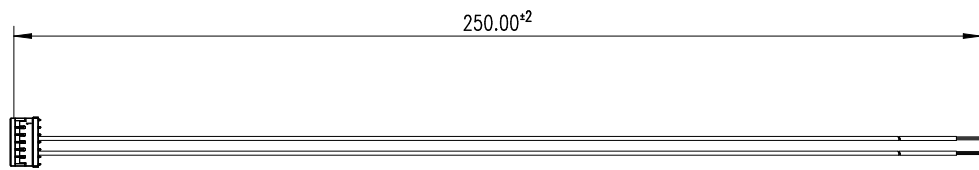

**Fig. 8-10** Power Supply Cable ETV5

#### Usage

The ETV5 cable is an open wire power supply cable with one battery and GND connection.



#### NOTE

For better power integrity cut the cable to the shortest possible length.

#### Pin Assignment

Pin Number	Color	Signal	Description
1			Not connected
2			Not connected
3	Brown	GND	Power GND
4			Not connected
5	Red	SGUBATT1	Car Battery
6			Not connected

#### Temperature Range

Condition	Temperature
Operating temperature	-40 °C to +110 °C

#### Ordering

Product	Length	Order Number
ETV5	0.25 m	F 00K 111 701



8.5.2 Cable K70.1

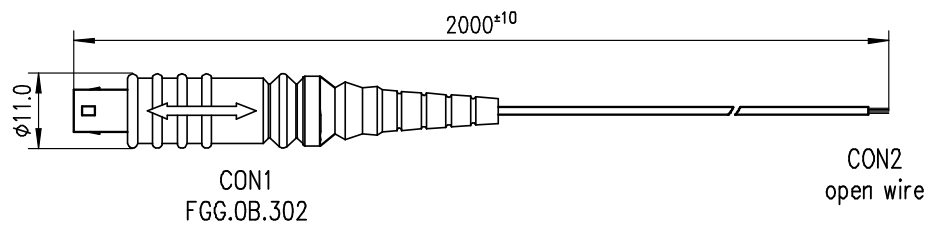

Fig. 8-11 Power Supply Cable K70.1

Dim	Millimeters	Inches
A	2000	78.74

8.5.3 Power Supply Cable KA50

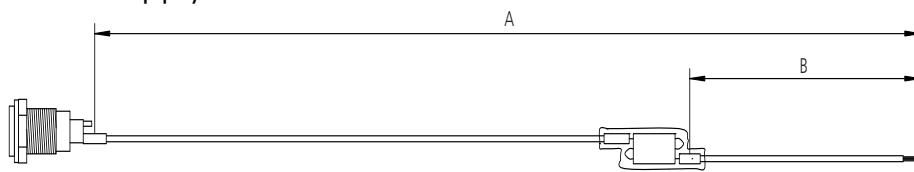
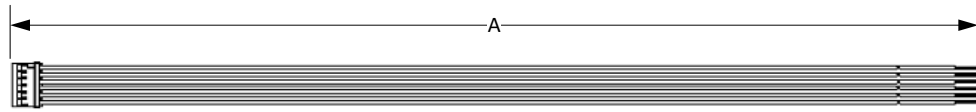

Fig. 8-12 Power Supply Cable KA50

Dim	Millimeters	Inches
A	200	7.87
B	50	1.97

## 8.6 ECU Interface Adapters

### 8.6.1 XETK - ECU Adapter ETAM2



**Fig. 8-13** XETK - ECU Adapter ETAM2

Dim	Millimeters	Inches
A	250.00	9.84

### 8.6.2 XETK - ECU Adapter ETAM5

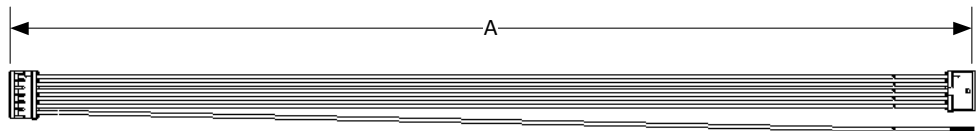

**Fig. 8-14** XETK - ECU Adapter ETAM5

Dim	Millimeters	Inches
A	136.0	5.35



**NOTE**

See Fig. 4-6 on page 28 for details on mating connector to the ETAM5.

### 8.6.3 XETK - ECU Adapter ETAM9

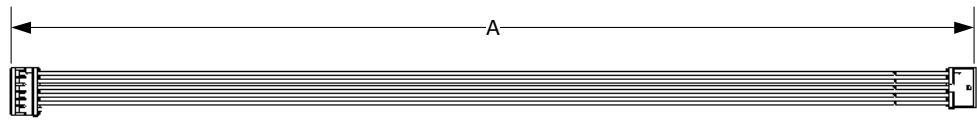
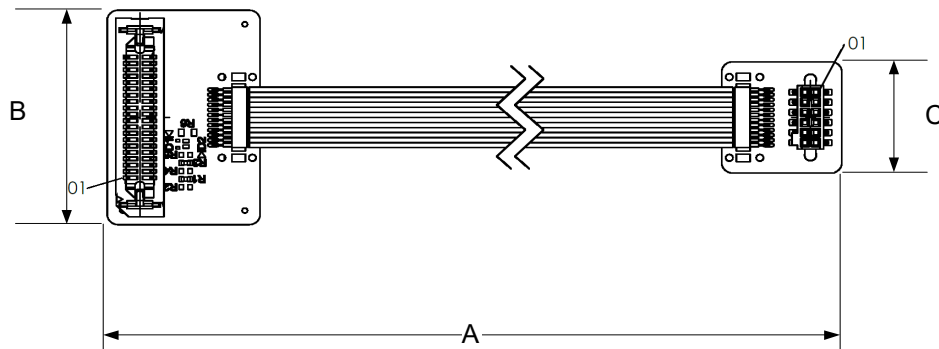

**Fig. 8-15** XETK - ECU Adapter ETAM9

Dim	Millimeters	Inches
A	136	5.35

**i** NOTE  
See Fig. 4-6 on page 28 for details on mating connector to the ETAM9.

### 8.6.4 XETK - ECU Adapter ETAN4A



**Fig. 8-16** XETK - ECU Adapter ETAN4A

Dim	Millimeters	Inches
A	150	5.91
B	27	1.06
C	14	0.55

**i** NOTE  
See Fig. 4-6 on page 28 for details on mating connector to the ETAN4A.

#### ETAN4A Pin Assignment

Pin	Signal	Description
1	GND	Signal Ground
2	TCK	JTAG TCK signal
3	/TRST	JTAG /TRST signal
4	TDO	JTAG TDO signal
5	TMS	JTAG TMS signal
6	TDI	JTAG TDI signal

Pin	Signal	Description
7	FLMD0	Flash Mode 0 (WDGDIS)
8	VDD (Sense)	Sense for Switched power supply of ECU (ignition)
9	/RDY	JTAG Ready signal
10	/PORESET	ECU reset signal (open drain) for reset assertion and supervision
11	VSTBY (Sense)	Sense the supply of the standby (WP) RAM
12	/RESETOUT	ECU Internal Reset Status (sense)

**NOTE**

For additional details on the ETAN4A cable, please request the ETAN4A User Guide.

### 8.7 Water proof Case ETKS\_C3

For mounting the XETK-S16.0 on top of ECUs, an external case is available. It is small, robust and water proof (IP65).

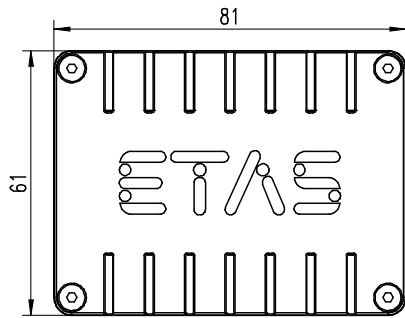

Fig. 8-17 ETKS\_C3 Top View

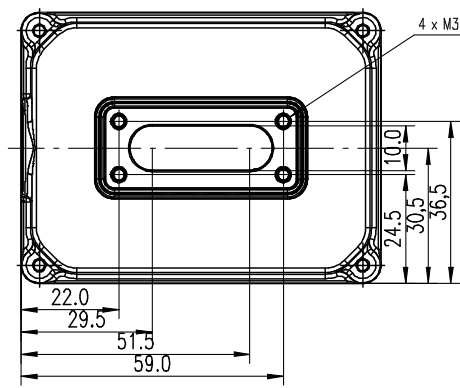

Fig. 8-18 ETKS\_C3 Bottom View

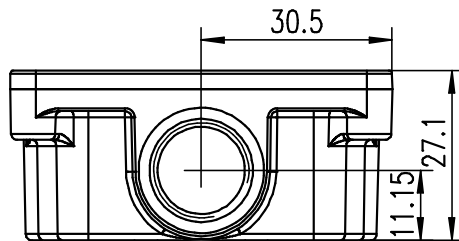

Fig. 8-19 ETKS\_C3 Side View

## 9 Ordering Information

### 9.1 XETK-S16.0

Order Name	Short Name	Order Number
XETK-S16.0A Emulator Probe for ARM micro-controllers	XETK-S16.0A	F 00K 112 258
<b>Package Contents</b>		
<ul style="list-style-type: none"> <li>- XETK-S16.0 Emulator Probe for ARM micro-controllers including gap pad,</li> <li>- List "Content of this Package",</li> <li>- ETK Safety Advice,</li> <li>- China-RoHS-leaflet</li> </ul>		

### 9.2 XETK - ECU Adapter

Order Name	Short Name	Order Number
ETAN4A XETK ECU adapter for mounting in external housing, SAMTEC - SAMTEC (40fc - 12fc), 0m136	ETAN4A	F 00K 111 423
ETAM2 XETK/FETK ECU Adapter, Molex - open wires (6fc - 6c), 0m25	ETAM2	F 00K 109 306
ETAM5 XETK/FETK ECU Adapter, Molex - Molex (6fc - 5fc+1c), 0m136	ETAM5	F 00K 110 101
ETAM9 F/XETK-S ECU Adapter, MOLEX - MOLEX (6fc - 5fc), 0m136	ETAM9	F 00K 111 043
ETV5 XETK/FETK ECU Adapter, Molex - open wires (6fc - 2c), 0m25	ETV5	F 00K 111 701

### 9.3 Power Supply

Order Name	Short Name	Order Number
Isolated Power Supply Interface for XETK	ETP2	F 00K 104 010

### 9.4 Mounting Material

Order Name	Short Name	Order Number
Gap Pad as spare part for XETK-S16.0	XETK-S22_GP	F 00K 111 041 No longer available

## 9.5 Cables

Please contact your local ETAS representative for further cable information.



### NOTE

The cables showed in chapter "Cables and Accessories" on page 51 are not included in the XETK-S16.0 delivery.

### 9.5.1 ECU Adapter Cables



### NOTE

The hardware for mounting ECU adapter cable CBAM240 is not included in the cable delivery, they need to be ordered separately. For detailed information on mounting accessories contact ETAS technical support.

Order Name	Short Name	Order Number
XETK ECU Adapter Cable, 100 Mbit/s, Shield on ECU-Housing, Lemo 1B HME - JST PHE (10fc-5fc), 0m38	CBAM230-0m38	F 00K 105 791
XETK ECU Adapter cable, 100 Mbit/s, Lemo 1B HME - JST PHE (10fc-5fc), 0m6	CBAM240-0m6	F 00K 105 792
XETK ECU Adapter Cable, pre-assembled into PG9 screwing, shield on ECU- Housing, Lemo 1B PHE - JST PHR (10fc-5fc), 0m50	CBAM271-0m5	F 00K 107 867

### 9.5.2 Combined ECU Adapter and Power Supply Cables

Order Name	Short Name	Order Number
XETK ECU Adapter and Power Supply Cable, pre-assembled into PG9 screwing, shield on ECU-Housing, Lemo 1B PHE - JST PHR (10fc-5fc) / Lemo 0B PHG - JST PAP (2fc-2fc), 0m50	CBAM270-0m5	F 00K 107 866
XETK ECU Adapter and Power Supply Cable, pre-assembled into PG9 screwing, shield on ECU-Housing, Lemo 1B PHE - JST PHR (10fc-5fc) / Lemo 0B PHG - JST PAP (2fc-2fc), 0m70	CBAM270-0m7	F 00K 108 479

### 9.5.3 Ethernet Cables

#### PC Interface Cable

Order Name	Short Name	Order Number
Ethernet PC Connection Cable 1 GBit/s, Lemo 1B FGE - RJ45 (10mc-8mc), 3 m	CBE200-3	F 00K 104 373
Ethernet PC Connection Cable 1 GBit/s, Lemo 1B FGE - RJ45 (10mc-8mc), 8 m	CBE200-8	F 00K 104 374
Ethernet Connection Adapter Cable 1 GBit/s, Lemo 1B PHE - RJ45 (10fc- 8mc), 1m2	CBAE200-1m2	F 00K 105 760

#### ES600 / ES910 Interface Cable

Order Name	Short Name	Order Number
Ethernet Connection Cable 1 GBit/s, Lemo 1B FGE - Lemo 1B FGE (10mc- 10mc), 3 m	CBE230-3	F 00K 105 757
Ethernet Connection Cable 1 GBit/s, Lemo 1B FGE - Lemo 1B FGE (10mc- 10mc), 8 m	CBE230-8	F 00K 105 758

#### ES600 Interface Adapter Cable

Order Name	Short Name	Order Number
Ethernet Connection Adapter Cable 1 GBit/s to 100 MBit/s, Lemo 1B PHE - Lemo 1B FGF (10fc- 8mc), 0m5	CBAE330-0m5	F 00K 105 759

### 9.5.4 Power Supply Cables

Order Name	Short Name	Order Number
ETV5 F/XETK-S ECU Adapter, MOLEX - open wires (6fc - 2c), 0m25	ETV5	F 00K 111 701
External Power Supply Cable for ETkS, Lemo 0B FGG - open wire (2mc-1c), 2m	K70.1	F 00K 109 270
XETK Power Supply Cable for External Supply, with Filter Coil, Lemo 0B EGG - open wire (2fc- 1c), 0m2	KA50	F 00K 000 940

### 9.6 Waterproof Case

Order Name	Short Name	Order Number
Water proof case, designed for XETK-S4.x, ETK-S6.x, XETK-S2x and XETK-S16.0.	ETKS_C3	F 00K 107 683
Lemo 1B Cap LC	CAP_LEMO_1B_ LC	F 00K 105 683



## 10 Contact Information

### Technical Support

For details of your local sales office as well as your local technical support team and product hotlines, take a look at the ETAS website:

[www.etas.com/en/hotlines.php](http://www.etas.com/en/hotlines.php)

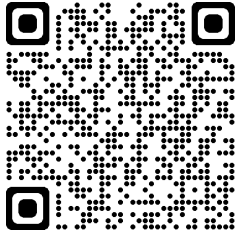

### ETAS Headquarters

ETAS GmbH

Borsigstraße 24  
70469 Stuttgart  
Germany

Phone: +49 711 3423-0  
Fax: +49 711 3423-2106  
Internet: [www.etas.com](http://www.etas.com)

## Figures

Fig. 1-1	WEEE-Symbol	11
Fig. 2-1	XETK-S16.0	13
Fig. 3-1	XETK-S16.0 Architecture	15
Fig. 3-2	Location of the ECU Interface connectors	16
Fig. 3-3	Location of the XETK Ethernet Interface connector (CON2)	17
Fig. 3-4	Location of the Debugger Interface connector CON3	18
Fig. 3-5	Location of the XETK-S16.0 Power Supply Connector CON4	18
Fig. 3-6	Status LEDs of the XETK-S16.0	20
Fig. 3-7	Equivalent Circuitry of the ECU JTAG Interface (ECU)	22
Fig. 4-1	XETK-S16.0 bottom side view	26
Fig. 4-2	XETK-S16.0 with properly positioned Gap Pad	26
Fig. 4-3	XETK-S16.0 mounting materials	27
Fig. 4-4	XETK-S16.0 mounted	27
Fig. 4-5	XETK-S16.0 Connection to the ECU	28
Fig. 4-6	XETK-S16.0 Connection to the ECU	28
Fig. 4-7	Wiring - XETK Ethernet Interface	29
Fig. 4-8	Permanent Power Supply inside ECU available	30
Fig. 4-9	Permanent Power Supply inside ECU not available	31
Fig. 4-10	Isolated Power Supply inside ECU	31
Fig. 7-1	XETK-S16.0 Dimensions - Top View	50
Fig. 7-2	XETK-S16.0 Dimensions - Side View	50
Fig. 8-1	CBAM230 Adapter Cable	51
Fig. 8-2	CBAM240 Adapter Cable	51
Fig. 8-3	CBAM271 Adapter Cable	52
Fig. 8-4	CBAM270 Cable (0.5 m length)	53
Fig. 8-5	CBAM270 Cable (0.7 m length)	53
Fig. 8-6	CBE200 Cable	54
Fig. 8-7	CBAE200 Adapter Cable	54
Fig. 8-8	CBE230 Cable	55
Fig. 8-9	CBAE330 Adapter Cable	55
Fig. 8-10	Power Supply Cable ETV5	56
Fig. 8-11	Power Supply Cable K70.1	57
Fig. 8-12	Power Supply Cable KA50	57
Fig. 8-13	XETK - ECU Adapter ETAM2	58
Fig. 8-14	XETK - ECU Adapter ETAM5	58
Fig. 8-15	XETK - ECU Adapter ETAM9	59
Fig. 8-16	XETK - ECU Adapter ETAN4A	59

67 | Figures

Fig. 8-17	ETKS_C3 Top View .....	61
Fig. 8-18	ETKS_C3 Bottom View .....	61
Fig. 8-19	ETKS_C3 Side View .....	61

## Index

<b>A</b>	
Adapter	
ETAM2	58
ETAM5	58
ETAM9	59
ETAN4A	59
Adapters	58
Applications	13
Architecture	15
<b>B</b>	
Block diagram	15
<b>C</b>	
Cable	
CBAE200	54
CBAE330	55
CBAM230	51
CBAM240	51
CBAM270	53
CBAM271	52
CBE200	54
CBE230	55
ETV5	56
Interface	51
Power Supply	56
Configuration	37
Parameter	33
<b>D</b>	
Data	
Emulation	21
Emulation Memory	37
Measurement	21
Debug Adapter	62
<b>E</b>	
ECU	
Interface	16, 18
Interface Characteristics	43
Voltage Supervisor	19
Electrical Characteristics	43
Environmental Conditions	38
Ethernet Interface	17
ETK Configuration	32
ETKS_C3	61
<b>F</b>	
Features	14
<b>H</b>	
Hardware Description	15
<b>I</b>	
Identifications on the product	10
Interface	
Cables	51
ECU	16, 18
Introduction	13
Isolated Power Supply	31
<b>J</b>	
JTAG Interface	22
<b>L</b>	
LED	20
<b>M</b>	
Measurement Data Memory	37
Mechanical Dimension	50
<b>O</b>	
Ordering Information	62
<b>P</b>	
PC Interface Cable	54
PC network adapter	35
Pin Assignment	48
Power Supply	18, 19, 30, 62
Cables	64
Cables, combined	63
Connector	18
Product Back	11
<b>R</b>	
REACH regulation (EU)	12
Recycling	11
Reset	24
RoHS conformity	
China	12
European Union	11
<b>S</b>	
Software Support	36
Status LED	20
System Requirements	35
<b>T</b>	
Test Characteristics	40
Troubleshooting	34
<b>U</b>	
UKCA conformity	11
<b>V</b>	
Voltage Supervisor	19
<b>W</b>	
Waste Electrical and Electronic Equipment	11
WEEE	11
WEEE take-back system	11
<b>X</b>	
XETK Ethernet Interface	17