

RTA-OS

Spansion FR81 with the Softune Compiler

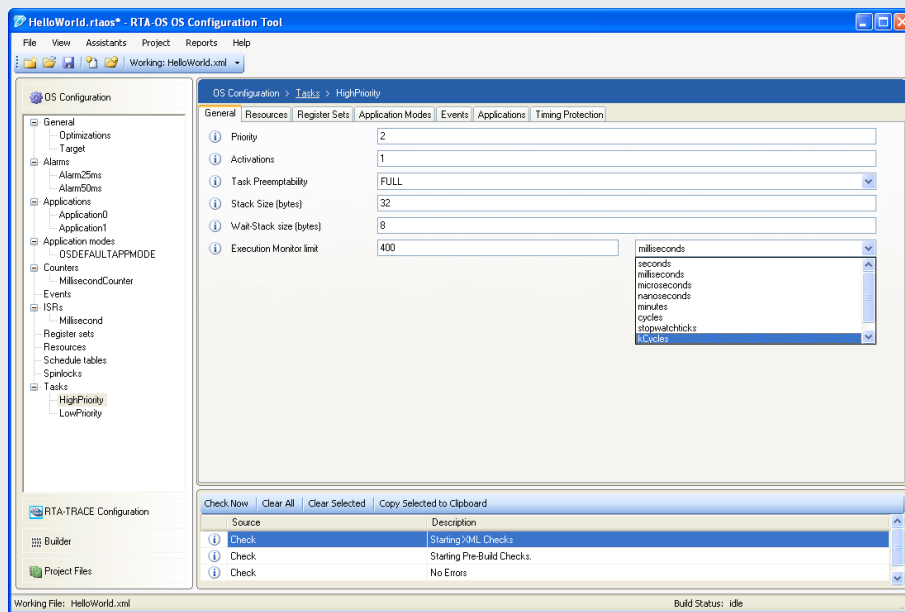

RTA-OS

RTA-OS is the new generation operating system from ETAS that conforms to the AUTOSAR OS specification and builds on the benefits of the successful RTA-OSEK product. It provides a toolsuite that includes a PC-based graphical configuration tool and adaptive OS generation capabilities to deliver flexible, fast solutions for a wide range of automotive microcontrollers.

The graphical configuration tool allows all OS objects to be configured, and creates AUTOSAR conformant XML files describing the OS configuration. In addition, it provides automatic verification against the AUTOSAR XML schema and allows users to create projects for easy management of multiple files.

RTA-OS improves on RTA-OSEK in several areas, including better runtime performance and smaller memory footprint, support for multiple processor environments, and automatic support for up to 1024 tasks. The po-

werful performance analysis tools developed for RTA-OSEK have been updated for RTA-OS to allow hard real-time requirements to be met.

RTA Product Family

RTA-OS integrates seamlessly with other tools in the RTA product family, including:

- RTA-RTE – a mature, robust production quality AUTOSAR RTE Generator.
- RTA-TRACE – a software logic analyser that allows the runtime behaviour of RTA-OS to be observed.

Microcontroller Support

RTA-OS supports all variants of the Spansion FR81 family of microcontrollers. Release testing has taken place using the MB91F52xY variant.

Features at a Glance

AUTOSAR R4.0 compliant OS

Supports all scalability classes

MISRA-C:2004 compliant

RTOS overhead:
69 bytes RAM
0 bytes ROM

Category 2 ISR latency:
52 CPU cycles

Compiler Software

RTA-OS for the Spansion FR81 has been developed with the Softune V65L06R03 compiler.

Due to the adaptive code generation of RTA-OS, it is possible to use other versions of this compiler to build applications.

Interrupt Model

RTA-OS supports 16 nested levels of interrupts on the Spansion FR81.

Memory Model

RTA-OS supports the standard 32 bit flat memory model provided by the Softune compiler.

In addition to the OS overhead, each object used by an application has the following memory requirements:

Maximum Number of OS Objects Allowed by RTA-OS

	BCC1	BCC2	ECC1	ECC2
Max. no. of tasks		Up to 1024		
Max. tasks per priority		Up to 1024		
Max. queued activations	1	$2^{32}-1$	1	$2^{32}-1$
Max. events per task	n/a	n/a	32	32
Max. alarms		$2^{32}-1$		
Max. software counters		$2^{32}-1$		
Max. hardware counters		$2^{32}-1$		
Max. nested resources		$2^{32}-1$		
Max. standard resources		$2^{32}-1$		
Max. internal resources	Not limited by RTA-OS			
Max. application modes		$2^{32}-1$		
Max. schedule tables		$2^{32}-1$		
Max. expiry points per schedule table		$2^{32}-1$		

Memory Overhead of RTA-OS

Memory Type	Overhead (bytes)
RAM	69
ROM/Flash	0

Object	RAM (bytes)	ROM (bytes)
Task	0	16
Category 2 ISR	0	8
Resource	4	8
Alarm	12	2
Counter	4	20
Schedule Table	16	16
Expiry Point	0	4

Performance

The following table gives the key RTA-OS kernel performance data measured in CPU cycles. All measurements were taken on a Spansion FR81 MB91F52xY with a 80MHz clock speed.

Task Type	Execution Time	Ref.
Pre-emption	102	A
Normal Termination	61	B
Task Switch	64	C
ChainTask	128	D
WaitEvent	265	E
SetEvent	348	F
Schedule	91	G
ReleaseResource	89	H
Category 2 ISR Entry Latency	52	I
Category 2 ISR Exit Latency resuming interrupted task	63	J
Category 2 ISR Exit Latency with task switch	93	K
Category 1 ISR Latency	20	L

The following figures illustrate how the RTA-OS kernel overheads are allocated during the operations given in the above table:

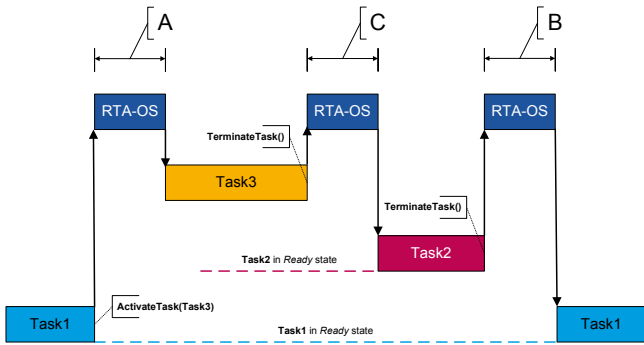

Figure 1 - Task1 is preempted by Task3, followed by a task switch and then normal termination of Task2

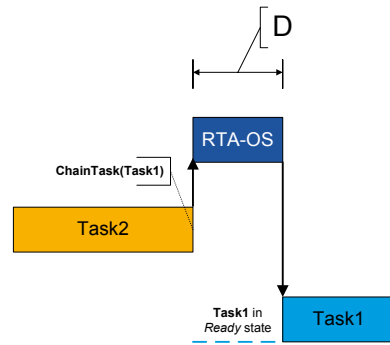

Figure 2 - Task2 chains Task1

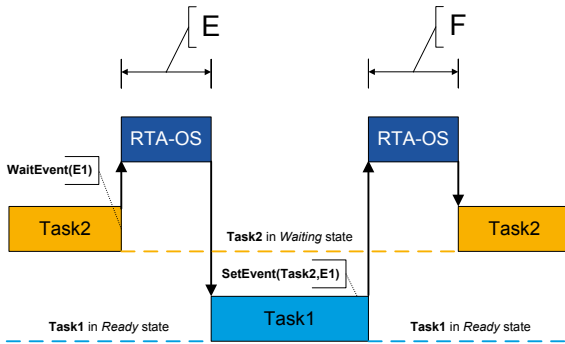

Figure 3 - Task2 waits for an event set by Task1

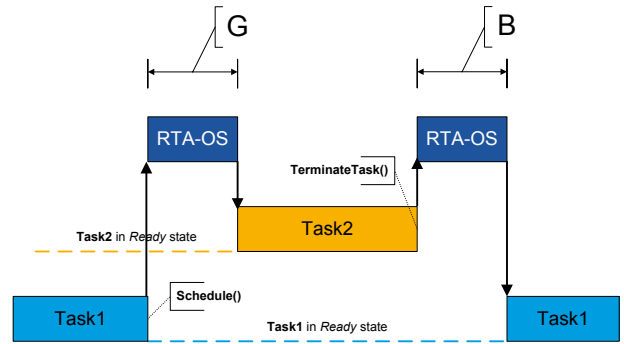

Figure 4 - Task1 allows cooperative scheduling by Task2

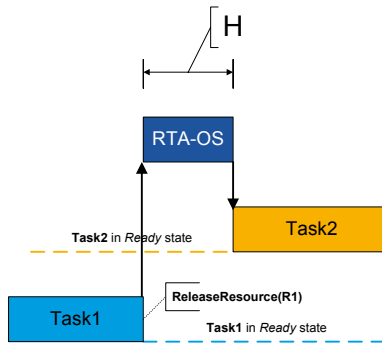

Figure 5 - Task1 releases a resource

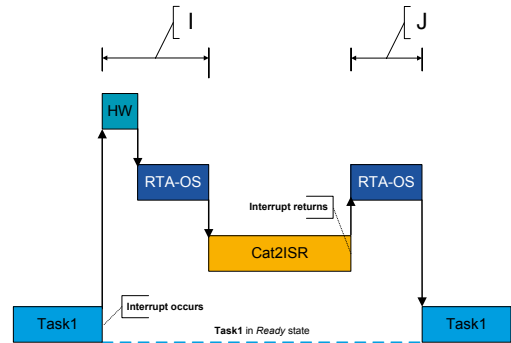

Figure 6 - Category2 ISR entry and exit latency

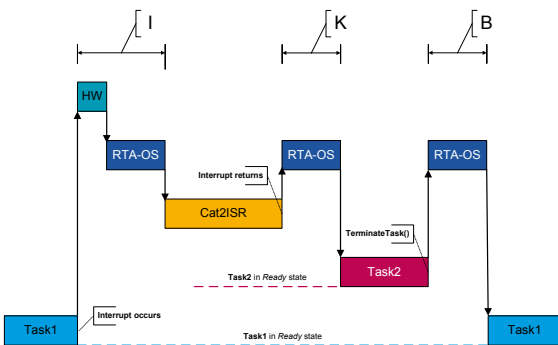

Figure 7 - Category2 ISR switches to Task2

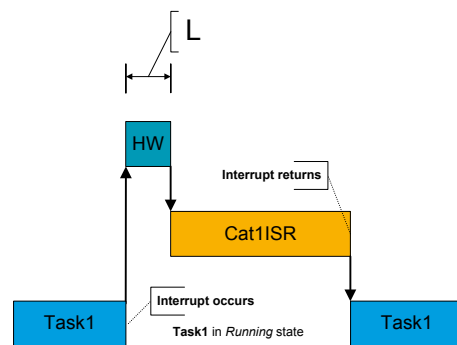

Figure 8 - Category1 ISR entry latency

Order Information

To use RTA-OS it is necessary to purchase a development license for the tools together with an add-on license for the Spansion FR81 port. Machine-named, user-named and floating licenses are available.

To use any operating system code generated by RTA-OS in ECU applications, a valid production license is required. Please contact your local ETAS Sales Office for details of production licenses for RTA-OS.

RTA-OS Tools Order Information

Item	Characteristics	Object
F 00K 107 119	Machine-named license for RTA-OS for Windows PC	LD_RTА-OS_VRTA_SC34_LIC-MP
F 00K 107 120	User-named license for RTA-OS for Windows PC	LD_RTА-OS_VRTA_SC34_LIC-UP
F 00K 107 121	Floating license for RTA-OS for Windows PC	LD_RTА-OS_VRTA_SC34_LIC-CP
F 00K 107 136	Product CD for RTA-OS	LD_RTА-OS_VRTA_SC34_PROD

RTA-OS Spansion FR81 Port Order Information

Item	Characteristics	Object
F 00K 109 753	Machine-named license for RTA-OS for Spansion FR81 Scalability Classes 1 & 2	ES_RTА-OS_PORT_SC12_LIC-MP
F 00K 109 754	User-named license for RTA-OS for Spansion FR81 Scalability Classes 1 & 2	ES_RTА-OS_PORT_SC12_LIC-UP
F 00K 109 755	Floating license for RTA-OS for Spansion FR81 Scalability Classes 1 & 2	ES_RTА-OS_PORT_SC12_LIC-CP
F 00K 109 756	Machine-named license for RTA-OS for Spansion FR81 Scalability Classes 1 to 4	ES_RTА-OS_PORT_SC34_LIC-MP
F 00K 109 757	User-named license for RTA-OS for Spansion FR81 Scalability Classes 1 to 4	ES_RTА-OS_PORT_SC34_LIC-UP
F 00K 109 758	Floating license for RTA-OS for Spansion FR81 Scalability Classes 1 to 4	ES_RTА-OS_PORT_SC34_LIC-CP
F 00K 109 765	Product CD for RTA-OS for Spansion FR81	ES_RTА-OS_PORT_PROD

ETAS GmbH

70469 Stuttgart, Germany
 Phone +49 711 89661-0
 Fax +49 711 89661-106
 sales.de@etas.com

ETAS S.A.S.

93404 Saint-Ouen Cedex
 France
 Phone +33 1 75 34 50-50
 Fax +33 1 40 10 11-64
 sales.fr@etas.com

ETAS Ltd.

Derby DE21 4SU
 United Kingdom
 Phone +44 1332 253770
 Fax +44 1332 253779
 sales.uk@etas.com

ETAS Inc.

Ann Arbor, MI 48103, USA
 Phone +1 888 ETAS INC
 Fax +1 734 997-9449
 sales.us@etas.com

ETAS K.K.

Yokohama 220-6217, Japan
 Phone +81 45 222-0900
 Fax +81 45 222-0956
 sales.jp@etas.com

ETAS Korea Co., Ltd.

Seoul 137-889, Korea
 Phone +82 2 5747-016
 Fax +82 2 5747-120
 sales.kr@etas.com

ETAS (Shanghai) Co., Ltd.

Shanghai 200335, P.R. China
 Phone +86 21 5037 2220
 Fax +86 21 5037 2221
 sales.cn@etas.com

ETAS Automotive India Pvt. Ltd.

Bangalore 560 068, India
 Phone +91 80 4191 2585
 Fax +91 80 4191 2586
 sales.in@etas.com

www.etas.com