

Platform Software Framework for Vehicle Computers RTA-VRTE

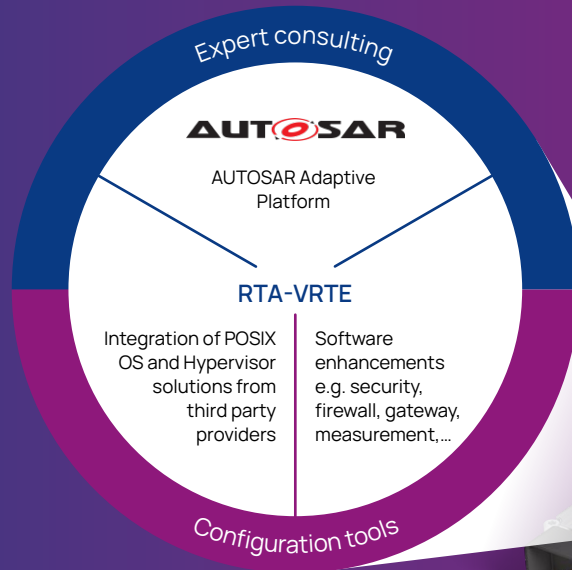

AUTOSAR Adaptive - ready for production!

ETAS supports and facilitates the development of software-defined vehicles (SDV).
RTA-VRTE comes with the following features:



Areas of application

Ready-to-use Software Development Kit (SDK) including all services to support the functional software.

RTA-VRTE can be used for all powerful, microprocessor-based vehicle computers, e.g. for domain controllers, HAD/ADAS and connectivity applications with the following requirements:

- AUTOSAR Adaptive architectures
- Software from various suppliers and safety classes on one control unit
- Software updates in the field
- Safety-critical systems up to ASIL D
- Vehicle-independent SW applications



Implementation

Get started quickly with a flexible solution:

- Ready to go Software Development Kit (SDK): The Starter Kit, consisting of RTA-VRTE SDK, configuration tools, training and consulting
- Customer-specific, modular, expandable and hardware-independent assembly solution
- Easy integration into the development landscape through a modular and integrated development environment for configuration and application development



Benefits

- Production-proven SW built from the ground-up for series development
- Access to extensive know-how through training and consulting: vehicle competence, expertise in E/E architectures, complex real-time software, IoT, and automotive hardware (in-vehicle and backend)
- High functional safety and reliability following automotive requirements as well as real-time behavior combined with cyber-security
- Supports use of automotive hypervisor for system security and testability through separation.

Software components of RTA-VRTE

The software components shown here are a comprehensive foundation for safe vehicle computers based on the AUTOSAR Classic and Adaptive standards.

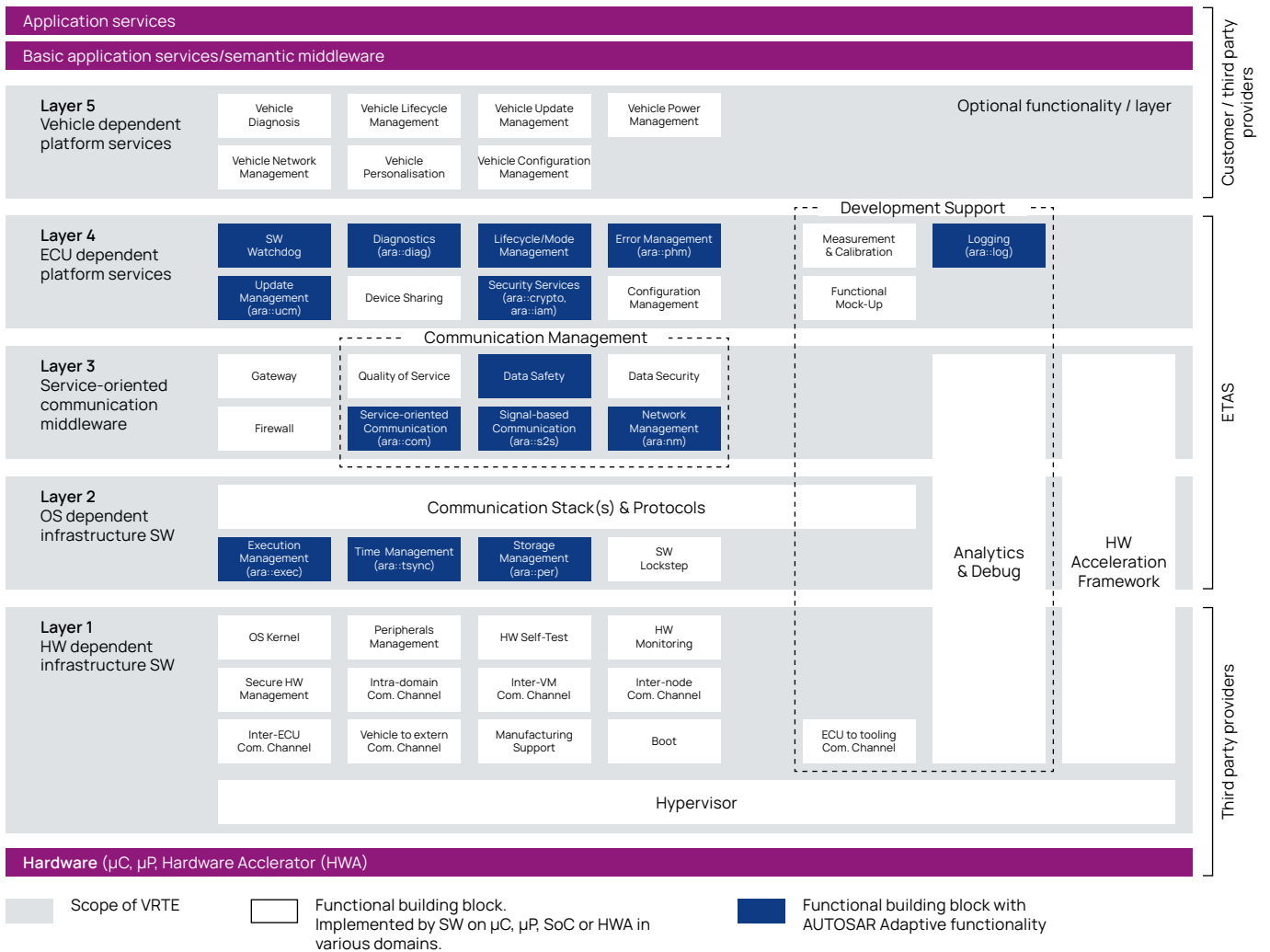

Structure of the RTA-VRTE Starter Kit

In addition to RTA-VRTE for series production, ETAS offers the RTA-VRTE Starter Kit. Start immediately with AUTOSAR Adaptive functions through the many included examples, combined with ETAS consulting and training to provide the necessary expertise.

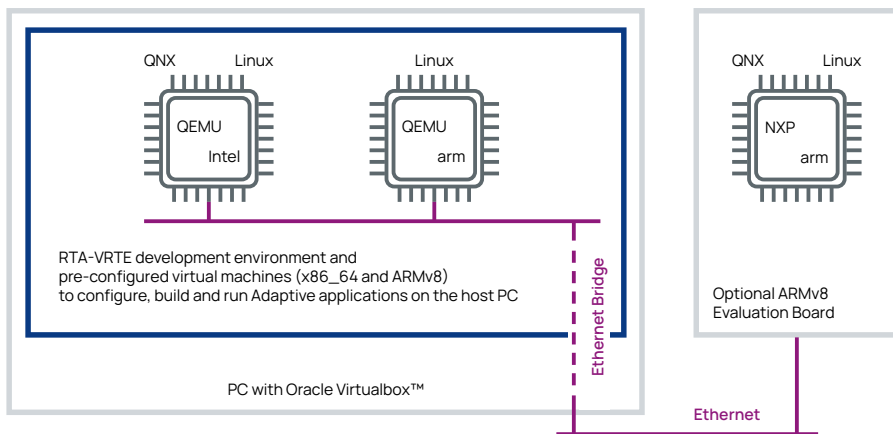

QNX virtual machines licences must be purchased separately
Use of HW EVB is optional and must be purchased separately

Services

- Ready to go pre-integrated development, configuration and execution environment
- Updates (limited duration)
- AUTOSAR Adaptive and RTA-VRTE training – online / on-site
- Consulting to kick-start your Adaptive development.
- Latest RTA-VRTE SDK

Are you interested in ETAS products?
Please contact our sales specialists: info@etas.com

More product information:
www.etas.com/vrte